

Camera Operations Guide

Read this first

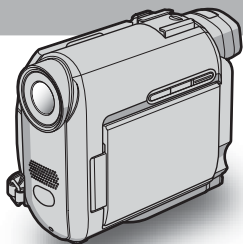

Digital Video Camera Recorder

HANDYCAM

DCR-HC20

Mini **DV** Digital
Video
Cassette

i InfoLITHIUM™ **P**
SERIES

Read this first

Before operating the unit, please read this manual thoroughly, and retain it for future reference.

WARNING

To prevent fire or shock hazard, do not expose the unit to rain or moisture.

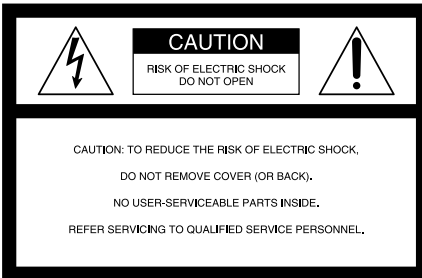

This symbol is intended to alert the user to the presence of uninsulated “dangerous voltage” within the product’s enclosure that may be of sufficient magnitude to constitute a risk of electric shock to persons.



This symbol is intended to alert the user to the presence of important operating and maintenance (servicing) instructions in the literature accompanying the appliance.

For customers in the U.S.A. and CANADA

RECYCLING LITHIUM-ION BATTERIES

Lithium-Ion batteries are recyclable. You can help preserve our environment by returning your used rechargeable batteries to the collection and recycling location nearest you.



For more information regarding recycling of rechargeable batteries, call toll free 1-800-822-8837, or visit <http://www.rbrcl.org/>

Caution: Do not handle damaged or leaking Lithium-Ion batteries.

Battery pack

This device complies with Part 15 of the FCC Rules. Operation is subject to the following two conditions: (1) This device may not cause harmful interference, and (2) this device must accept any interference received, including interference that may cause undesired operation.

This Class B digital apparatus complies with Canadian ICES-003.

For customers in the U.S.A.

If you have any questions about this product, you may call:

Sony Customer Information Center 1-800-222-SONY (7669)

The number below is for FCC related matters only. Regulatory Information

Declaration of Conformity

Trade Name: SONY
Model No.: DCR-HC20
Responsible Party: Sony Electronics Inc.
Address: 680 Kinderkamack Road, Oradell, NJ 07649 U.S.A.
Telephone No.: 201-930-6972

This device complies with Part 15 of the FCC Rules. Operation is subject to the following two conditions: (1) This device may not cause harmful interference, and (2) this device must accept any interference received, including interference that may cause undesired operation.

Owner's Record

The model and serial numbers are located on the bottom. Record the serial number in the space provided below. Refer to these numbers whenever you call upon your Sony dealer regarding this product.

Model No. DCR-HC _____

Serial No. _____

Model No.AC- _____

Serial No. _____

CAUTION

You are cautioned that any changes or modifications not expressly approved in this manual could void your authority to operate this equipment.

Note:

This equipment has been tested and found to comply with the limits for a Class B digital device, pursuant to Part 15 of the FCC Rules.

These limits are designed to provide reasonable protection against harmful interference in a residential installation. This equipment generates, uses, and can radiate radio frequency energy and, if not installed and used in accordance with the instructions, may cause harmful interference to radio communications. However, there is no guarantee that interference will not occur in a particular installation. If this equipment does cause harmful interference to radio or television reception, which can be determined by turning the equipment off and on, the user is encouraged to try to correct the interference by one or more of the following measures:

- Reorient or relocate the receiving antenna.
- Increase the separation between the equipment and receiver.
- Connect the equipment to an outlet on a circuit different from that to which the receiver is connected.
- Consult a Sony dealer or an experienced radio/TV technician for help.

The supplied interface cable must be used with the equipment in order to comply with the limits for a digital device pursuant to Subpart B of Part 15 of FCC Rules.

Notes on use

Note on Cassette Memory

Your camcorder is based on the DV format. You can use only mini DV cassettes in your camcorder. Use of

mini DV cassettes with Cassette Memory is recommended as you can use Title search (p. 40), Date search (p. 41), Photo search (p. 41), [TITLE] (p. 52), [TAPE TITLE] (p. 54).

Cassettes with Cassette Memory are marked with **CM**.

Notes on recording

- Before starting to record, test the recording function to make sure the picture and sound are recorded without any problems.
- Compensation for the contents of recordings cannot be provided, even if recording or playback is not possible due to a malfunction of the camcorder, etc.
- TV color systems differ depending on the countries/regions. To view your recordings on a TV, you need an NTSC system-based TV.
- Television programs, films, video tapes, and other materials may be copyrighted. Unauthorized recording of such materials may be contrary to the copyright laws.

Notes on the LCD panel, viewfinder, and lens

- The LCD screen and the viewfinder are manufactured using extremely high-precision technology, so over 99.99% of the pixels are operational for effective use.
However, there may be some tiny black points and/or bright points (white, red, blue, or green in color) that appear constantly on the LCD screen and the viewfinder.
These points are normal results of the manufacturing process and do not affect the recording in any way.
- Exposing the LCD screen, the viewfinder, or the lens to direct sunlight for long periods of time may cause malfunctions. Be careful when placing the camera near a window or outdoors.
- Do not aim at the sun. Doing so might cause your camcorder to malfunction. Take pictures of the sun only in low light conditions, such as at dusk.

Note on connecting other device

Before connecting your camcorder to other device such as a VCR or a computer with a USB or i.LINK cable, be sure to insert the connector plug in the proper direction. If you insert the connector plug forcibly in the wrong direction, the terminal may be damaged, or this may cause a malfunction of your camcorder.

Note on using this manual

- The images of the LCD screen and the viewfinder used on this manual are captured using a digital still camera, and thus may appear different from what you see.

→ continued

Notes on using the camcorder

- Hold your camcorder correctly.

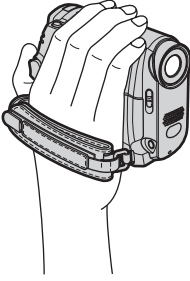

- If the Strap Belt is too long, fasten the Strap Belt as shown in the following illustration.

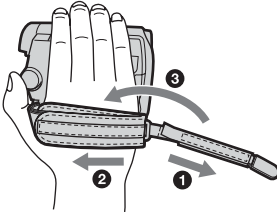

- You can also use the Strap Belt as a wrist strap. For details on the Strap Belt, see page 94.

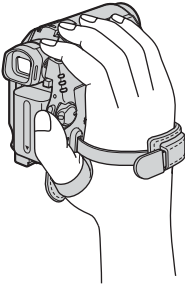

- When you are using the touch panel, place your hand on the back side of the LCD panel to support it. Then, touch the buttons displayed on the screen.
- Unavailable buttons will be grayed out.

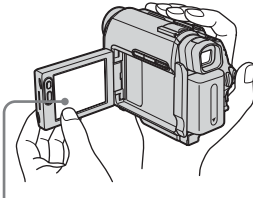

Touch the button on the LCD screen.

- You can change the language to be used for screen display on your camcorder (p. 20).
- Be careful not to press buttons beside the LCD screen accidentally when you open or close the LCD panel, or when you adjust the angle of the LCD panel.
- Do not hold the camcorder by the following parts.

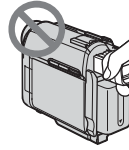

Viewfinder

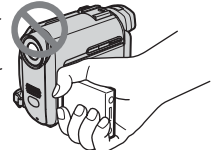

LCD panel

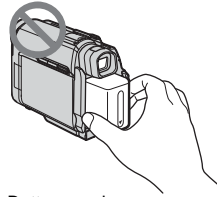

Battery pack

Table of Contents

Read this first	2
-----------------------	---

Quick Start Guide

Recording movies	8
Recording/Playing back with ease	10

Getting started

Step 1: Checking supplied items	11
Step 2: Charging the battery pack.....	12
Using an outside power source	14
Step 3: Turning the power on.....	15
Step 4: Adjusting the LCD panel and viewfinder.....	16
Adjusting the LCD panel	16
Adjusting the viewfinder	16
Step 5: Setting the date and time.....	17
Step 6: Inserting a cassette tape.....	19
Step 7: Setting the screen language.....	20

Recording

Recording movies	21
Recording for a longer time	22
Using zoom	22
Recording in mirror mode	22
Using the self-timer	23
Recording still images – Tape photo recording.....	24
Recording with ease – Easy Handycam	25
Adjusting the exposure.....	26
Adjusting the exposure for backlit subjects	26
Fixing the exposure for the selected subject – Flexible spot meter	26
Adjusting the white balance manually	27
Adjusting the exposure manually	28
Recording in dark places – NightShot plus	29
Adjusting the focus.....	29
Adjusting the focus for an off-center subject – SPOT FOCUS	29
Adjusting the focus manually	30

→ *continued*









Recording a picture using various effects	31
Fading in and out of a scene – FADER	31
Searching for the starting point	32
Searching for the last scene of the most recent recording – END SEARCH	32
Searching manually – EDIT SEARCH	32
Reviewing the most recently recorded scenes – Rec review	33

Playback

Viewing pictures recorded on a tape.....	34
Playing back in various modes	35
Playing back with ease – Easy Handycam	36
Various playback functions	37
Displaying the screen indicators	37
Displaying the date/time and camera settings data – Data code	37
Playing the picture on a TV	39
Locating a scene on a tape for playback.....	40
Searching quickly for a desired scene – Zero set memory	40
Searching for a scene using Cassette Memory – Title search	40
Searching for a scene by date of recording – Date search	41
Searching for a still image – Photo search	41
Playing back still images in sequence – Photo scan	42

Advanced operations

Customizing Your Camcorder

Changing the menu settings	43
Using the  (MANUAL SET) menu – PROGRAM AE/P EFFECT, etc.	44
Using the  (CAMERA SET) menu – D ZOOM/16:9WIDE, etc.	47
Using the  (VCR SET) menu – HiFi SOUND/AUDIO MIX	50
Using the  (LCD/VF SET) menu – LCD B.L./LCD COLOR/VF B.L.	51
Using the  (CM SET) menu – TITLE/TAPE TITLE/ERASE ALL, etc.	52
Using the  (TAPE SET) menu – REC MODE/FRAME REC/ INT.REC, etc.	55
Using the  (SETUP MENU) menu – CLOCK SET/USB STREAM/ LANGUAGE, etc.	58
Using the  (OTHERS) menu – WORLD TIME, etc.	60

Dubbing/Editing

Connecting to a VCR or TV	62
Dubbing to another tape	63
Recording pictures from a VCR	63
Dubbing selected scenes from a tape – Digital program editing	64
Dubbing sound to a recorded tape	69
Creating DVDs or VCDs	71

Troubleshooting

Troubleshooting	72
Warning indicators and messages	78

Additional Information

Using your camcorder abroad	81
Usable cassette tapes	82
About the “InfoLITHIUM” battery pack	83
About i.LINK	85
Maintenance and precautions	86
Specification	89

Quick Reference

Identifying parts and controls	91
Index	98

Refer also to other operating instructions
supplied with your camcorder:

- Editing images with your computer
→ Computer Applications Guide

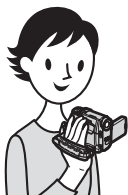

Quick Start Guide

Recording movies

1 Attach the charged battery pack to the camcorder.

To charge the battery, see page 12.

Slide the battery pack in the direction of the arrow until it clicks.

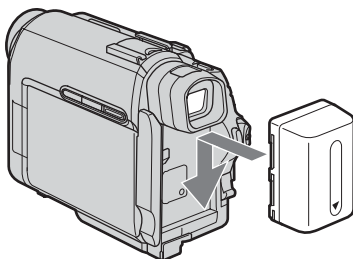

2 Insert a cassette into the camcorder.

- 1** Slide the **OPEN/▲EJECT▲** lever in the direction of the arrow to open the lid.
The cassette compartment comes out automatically.

OPEN/▲EJECT▲ lever

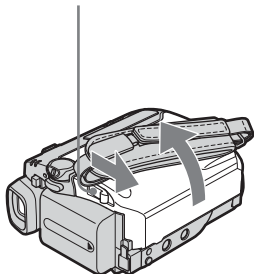

- 2** Insert the cassette with its window-side facing up, then push the center of the back of the cassette.

Window-side

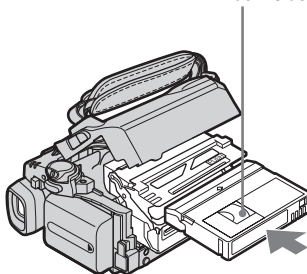

- 3** Press **PUSH**.
Close the cassette lid after the cassette compartment slides back in by itself.

PUSH

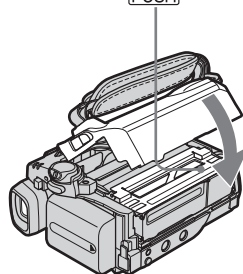

3 Start recording while checking the subject on the LCD screen.

The date and time is not set up in the default setting. To set the date and time, see page 17.

- ❶ Set the **LENS COVER** switch to **OPEN**.
- ❷ Open the **LCD panel**.
- ❸ While pressing the green button, slide the **POWER** switch down to light up the **CAMERA** lamp.

The power turns on.

- ❹ Press **REC START/STOP**.
Recording starts. To change to the standby mode, press **REC START/STOP** again. You can also record by pressing **REC START/STOP** beside the LCD screen.

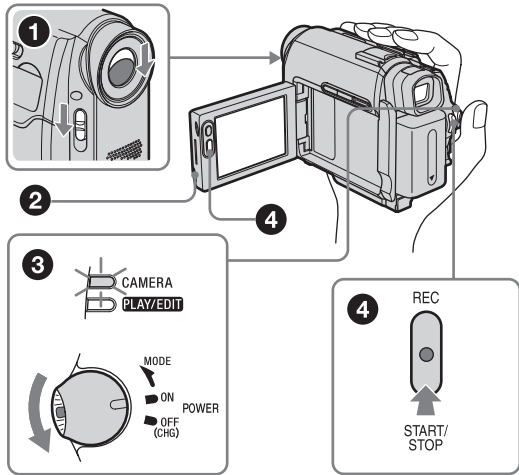

4 View the recorded picture on the LCD screen.

- ❶ Slide the **POWER** switch repeatedly until the **PLAY/EDIT** lamp lights up.
- ❷ Touch **⏮** (rewind).
- ❸ Touch **▶** (play) to start the playback.
To stop, press **■** (stop).

To turn off the power, slide the **POWER** switch up to **OFF (CHG)**, then set the **LENS COVER** switch to **CLOSE**.

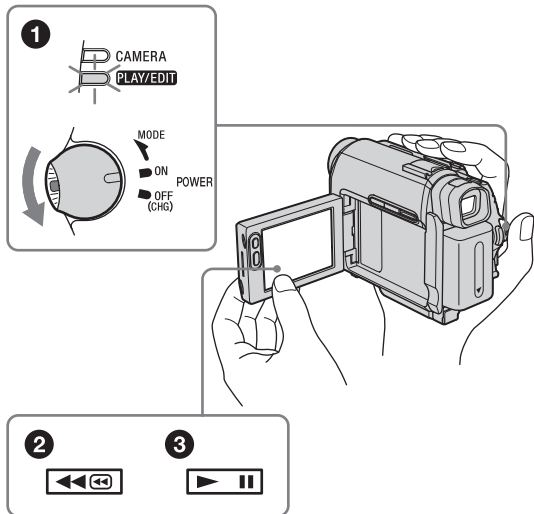

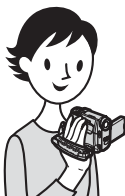

Recording/Playing back with ease

By switching to Easy Handycam operation, recording/playback operation becomes even easier.

Easy Handycam operation allows easy recording/playback for even first time users by providing only the basic functions for recording/playback.

Press EASY when recording/ playing back.

EASY lights up in blue (1) and the screen font size increases (2) during Easy Handycam operation.

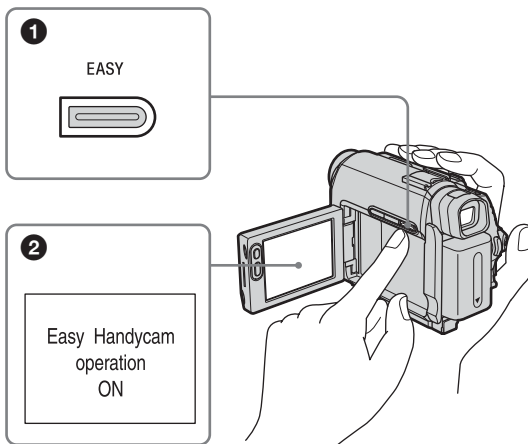

For details, see instructions for each operation.
See page 25 for recording, page 36 for playback.

Step 1: Checking supplied items

Make sure you have following items supplied with your camcorder.

The number in parentheses indicates the number of that item supplied.

AC Adaptor (1)

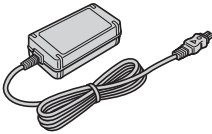

Power cord (1)



Wireless Remote Commander (1)

A button-type lithium battery is already installed.



A/V connecting cable (1)

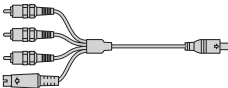

USB cable (1)

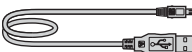

Rechargeable battery pack NP-FP50 (1)

CD-ROM "SPVD-012 USB Driver" (1)

Cleaning cloth (1)

Shoe cover (1)

Attached to the camcorder.

Camera Operations Guide (This manual) (1)

Computer Applications Guide (1)

Step 2: Charging the battery pack

You can charge the battery by attaching the “InfoLITHIUM” battery pack (P series) to your camcorder.

Notes

- You cannot use batteries other than the “InfoLITHIUM” battery pack (P series) (p. 83).
- Do not short-circuit the DC plug of the AC Adaptor or battery terminals with any metallic objects. This may cause a malfunction.
- Use a nearby wall outlet when using the AC Adaptor. Disconnect the AC Adaptor from the wall outlet immediately if any malfunction occurs.

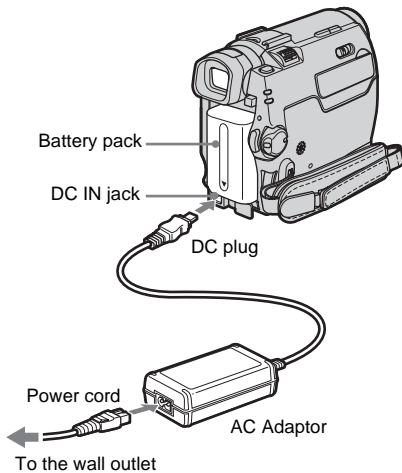

- 1 Attach the battery pack by sliding it in the direction of the arrow until it clicks.

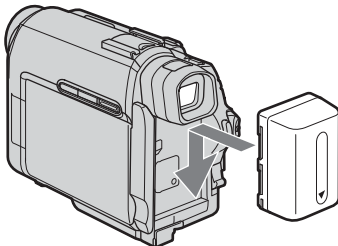

- 2 With the ▲ mark on the DC plug facing down, connect the AC Adaptor to the DC IN jack on your camcorder.

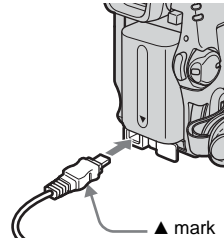

- 3 Connect the power cord to the AC Adaptor.

- 4 Connect the power cord to the wall outlet.

- 5 Set the POWER switch to OFF (CHG). The CHG (charge) lamp lights up and charging starts.

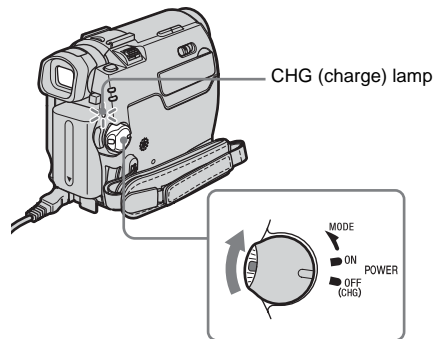

After charging the battery

The CHG (charge) lamp turns off when the battery is fully charged. Disconnect the AC Adaptor from the DC IN jack.

To remove the battery pack

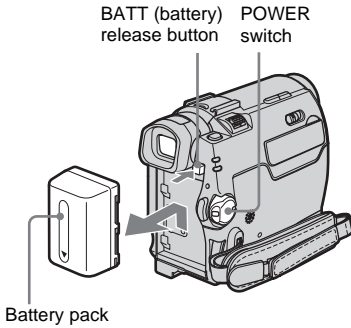

- 1 Set the **POWER** switch to **OFF (CHG)**.
- 2 Slide the battery pack out in the direction of the arrow while pressing the **BATT (battery) release button** down.

Note

- If you do not use the battery pack for a long time, use up the battery pack completely before storing it. See page 83 about storage of the battery pack.

To check the remaining battery – Battery Info

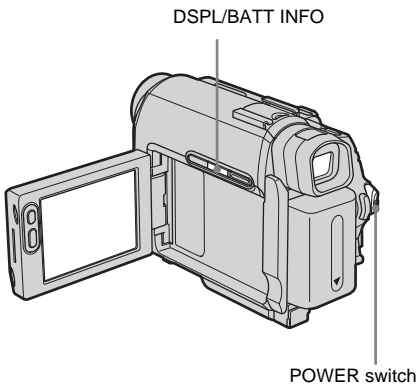

You can check the battery's current charge level and its current remaining recording time both during charging or when the power is turned off.

- 1 Set the **POWER** switch to **OFF (CHG)**.
- 2 Open the **LCD panel**.
- 3 Press **DSPL/BATT INFO**.
The battery information appears for about 7 seconds.

Keep the button pressed to view it for about 20 seconds.

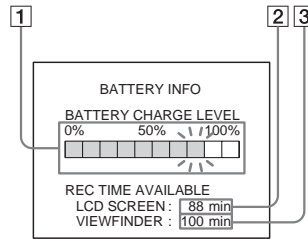

- 1 **Battery charge level: Displays approximate remaining amount of power left in the battery pack.**
- 2 **Approximate possible recording time using the LCD panel.**
- 3 **Approximate possible recording time using the viewfinder.**

Charging time

Approximate number of minutes required when you fully charge a fully discharged battery pack at 25°C (77°F). (10 – 30°C (50 – 86°F) recommended.)

Battery pack

NP-FP50 (supplied)	125
NP-FP70	155
NP-FP90	220

Recording time when recording with the LCD screen on

Approximate number of minutes available when you use a fully charged battery pack at 25°C (77°F).

When LCD BACKLIGHT is set to ON

Battery pack	Continuous recording time	Typical* recording time
NP-FP50 (supplied)	110	60
NP-FP70	235	125
NP-FP90	415	225

→ continued

When LCD BACKLIGHT is set to OFF

Battery pack	Continuous recording time	Typical* recording time
NP-FP50 (supplied)	125	65
NP-FP70	265	145
NP-FP90	475	260

Recording time when recording with the viewfinder

Approximate number of minutes available when you use a fully charged battery pack at 25°C (77°F).

Battery pack	Continuous recording time	Typical* recording time
NP-FP50 (supplied)	125	65
NP-FP70	265	145
NP-FP90	475	260

* Approximate number of minutes when recording while you repeatedly record, start/stop, slide the POWER switch to change the power mode, and zoom. The actual battery life may be shorter.

Playing time

Approximate number of minutes available when you use a fully charged battery pack at 25°C (77°F).

Battery pack	LCD panel opened*	LCD panel closed
NP-FP50 (supplied)	125	150
NP-FP70	265	310
NP-FP90	475	550

* With LCD BACKLIGHT set to ON.

⚡ Notes

- The power will not be supplied from the battery pack when the AC Adaptor is connected to the DC IN jack of your camcorder, even if its power cord is disconnected from the wall outlet.
- The recording and playback time will be shorter when you use your camcorder in low temperature.

- The CHG (charge) lamp flashes during charging, or the battery information will not be correctly displayed in following conditions.
 - The battery pack is not attached correctly.
 - The battery pack is damaged.
 - The battery pack is fully discharged. (For Battery information only)

Using an outside power source

You can use the AC Adaptor as the power source when you do not want the battery to run out. While you are using the AC Adaptor, the battery pack will not lose its charge even when it is attached to your camcorder.

PRECAUTION

Even if your camcorder is turned off, the AC power (house current) is still supplied to it while connected to the wall outlet via the AC Adaptor.

Connect your camcorder as shown in “Charging the battery pack” (p. 12).

Step 3: Turning the power on

You need to slide the POWER switch repeatedly to select the desired power mode to record or play.

When using this camcorder for the first time, the CLOCK SET screen appears (p. 17).

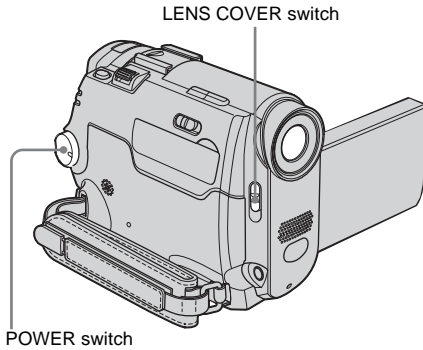

To turn off the power

Slide the POWER switch up to OFF (CHG), then set the LENS COVER switch to CLOSE.

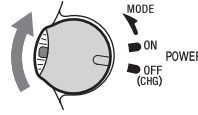

1 Set the LENS COVER switch to OPEN.

2 While pressing the green button, slide the POWER switch down.

The power turns on.

To enter the recording or playing mode, slide the switch repeatedly until the respective lamp for the desired power mode lights up.

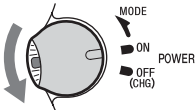

- CAMERA: To record on a tape.
- PLAY/EDIT: To play or edit pictures.

Step 4: Adjusting the LCD panel and viewfinder

Adjusting the LCD panel

You can adjust the angle and brightness of the LCD panel to meet various recording situations.

Even when there are obstructions between you and the subject, you can check the subject on the LCD screen during recording by adjusting the angle of the LCD panel.

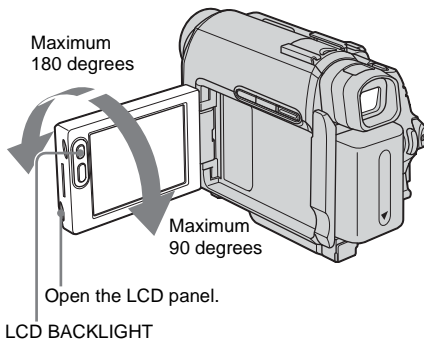

Open the LCD panel 90 degrees to the camcorder, then rotate it to the desired position.

To adjust the brightness of the LCD screen

- 1 When the POWER switch is set to the CAMERA mode, touch **[FN]** and select PAGE2.
When the POWER switch is set to the PLAY/EDIT mode, touch **[FN]** to display PAGE1.
- 2 Touch LCD BRT.

3 Adjust the brightness with **[−]/[+]**, then touch **[OK]**.

4 Touch **[X]**.

Tips

- The recorded picture will not be affected.
- If you rotate the LCD panel 180 degrees to the lens side, you can close the LCD panel with the LCD screen facing out.
- If you are using the battery pack for power source, you can adjust the brightness by selecting [LCD B.L.] on the **[LCD/VF SET]** menu (p. 51).
- When you use your camcorder in bright conditions, set LCD BACKLIGHT to turn off the backlight for the LCD panel. **[OFF]** appears and this setting saves battery power.
- You can turn off the confirmation beep sound for operation on the touch panel when you set [BEEP] to [OFF] on the **[ETC]** (OTHERS) menu (p. 60).

Adjusting the viewfinder

You can view images using the viewfinder when you close the LCD panel. Use the viewfinder when the battery is running out, or when the screen is hard to see.

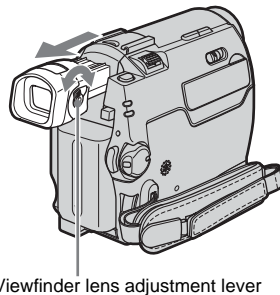

1 Extend the viewfinder.

2 Adjust the viewfinder lens adjustment lever until the picture is clear.

To use the viewfinder during operation

When you are recording, you can adjust the exposure (p. 28) and fader (p. 31) while checking the image on the viewfinder. Have the LCD panel rotated 180 degrees and closed with the screen facing out.

- 1 **Slide the POWER switch to select the CAMERA mode.** (p. 15)
- 2 **Extend the viewfinder, and close the LCD panel with the screen facing out.**
[OFF] appears on the screen.
- 3 **Touch [OFF].**
- 4 **Touch [OK].**
The LCD screen is turned off.
- 5 **Touch the LCD screen while checking the display in the viewfinder.**
EXPOSURE, etc. are displayed.
- 6 **Touch the button you want to set.**
 - EXPOSURE: Adjust with [-]/[+] and touch [OK].
 - FADER: Touch it repeatedly to select a desired effect.
 - [ON]: The LCD screen lights up.
To hide the buttons on the LCD screen, touch [OK].

Tip

- To adjust the brightness of the viewfinder backlight, select [LCD/VF SET], then [VF B.L.] (when you are using the battery pack, p. 51).

Step 5: Setting the date and time

Set the date and time when using this camcorder for the first time. If you do not set the date and time, the CLOCK SET screen appears every time you turn on your camcorder.

Note

- If you do not use your camcorder for about 3 months, the built-in rechargeable button-type battery gets discharged and the date and time settings may be cleared from the memory. In that case, charge the rechargeable button-type battery (p. 88) and then set the date and time again.

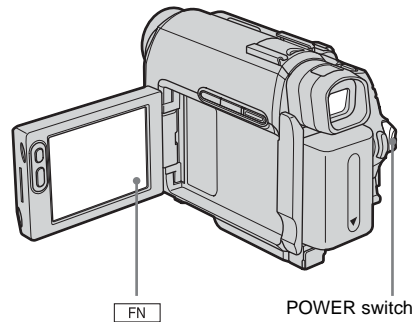

1 Turn on your camcorder (p. 15).

2 Open the LCD panel.

Proceed to step 7 when you set the clock for the first time.

→ continued

3 Touch **FN** to display PAGE1.

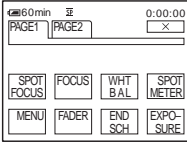

4 Touch **MENU**.

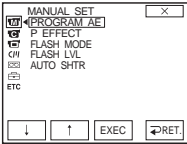

5 Select **SETUP MENU** with **↓** / **↑**, then touch **EXEC**.

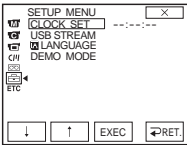

6 Select **CLOCK SET** with **↓** / **↑**, then touch **EXEC**.

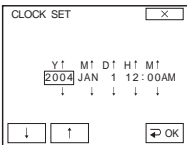

7 Set **Y** (year) with **↓** / **↑**, then touch **OK**.

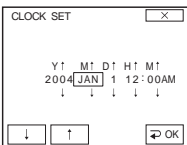

You can set any year up to the year 2079.

8 Set **M** (month), **D** (day), **H** (hour) and **M** (minute) in the same way as was done in step 7, then touch **OK**.

For midnight, set it to 12:00AM. For midday, set it to 12:00PM.

Step 6: Inserting a cassette tape

You can use mini DV ^{Mini}DV cassettes only. For details on these cassettes (such as write-protection), see page 82.

Note

- Do not force the cassette into the compartment. This may cause a malfunction of your camcorder.

- Slide the OPEN/▲EJECT ▼ lever in the direction of the arrow and open the lid.

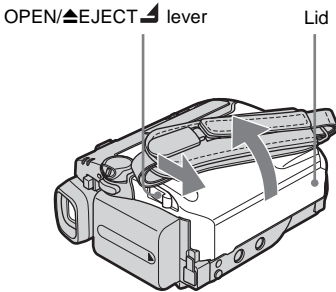

The cassette compartment automatically comes out and opens up.

- Insert a cassette with its window-side facing up.

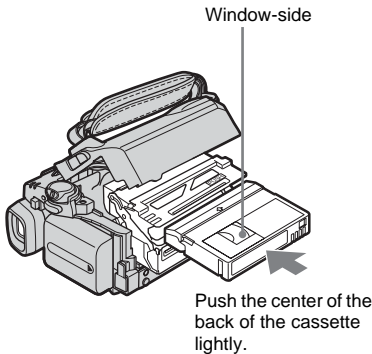

- Press [PUSH].

The cassette compartment automatically slides back in.

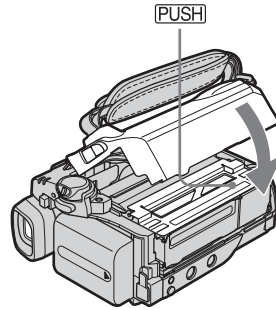

- Close the lid.

To eject the cassette

- Slide the OPEN/▲EJECT ▼ lever in the direction of the arrow and open the lid. The cassette compartment automatically comes out.
- Take out the cassette, then press [PUSH]. The cassette compartment automatically slides back in.
- Close the lid.

Step 7: Setting the screen language

You can select the language to be used on the LCD screen.

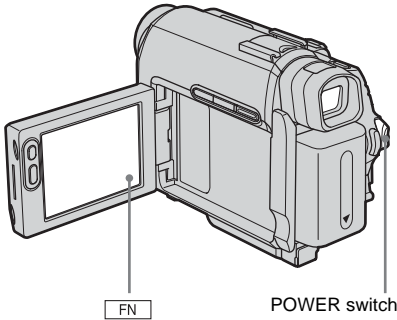

1 Turn on your camcorder.

2 Open the LCD panel.

3 Touch **FN** to display PAGE1.

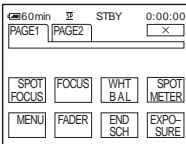

4 Touch **MENU**.

5 Select **SETUP MENU**, then select **LANGUAGE** with **↓** / **↑**, then touch **EXEC**.

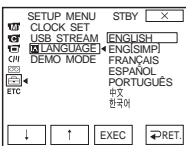

6 Select the desired language with **↓** / **↑**, then touch **EXEC**.

7 Touch **EXEC**.

Tip

- Your camcorder offers [ENG[SIMP]] (Simplified English) for when you cannot find your native tongue among the options.

Recording movies

Before recording, follow steps 1 to 7 in “Getting started” (p. 11 - p. 20).

When you are recording, movies will be recorded along with stereo sound.

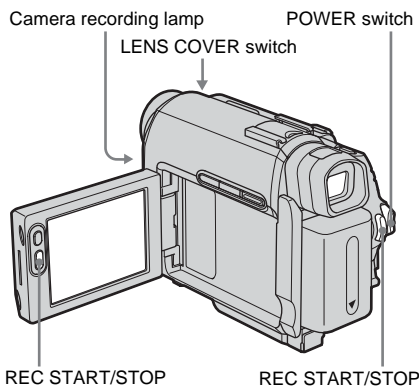

Tip

- Performing Easy Handycam operation, even first time users can record easily. For details, see page 25.

1 Set the LENS COVER switch to OPEN.

2 Open the LCD panel.

3 Slide the POWER switch until the CAMERA lamp lights up.

Your camcorder is set to the standby mode.

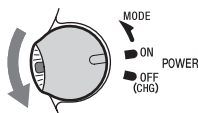

Slide the POWER switch while pressing the green button.

4 Press REC START/STOP.

Recording starts. [REC] appears on the LCD screen and the Camera recording lamp lights up.

Press REC START/STOP again to stop recording.

To turn the power off

Slide the POWER switch up to OFF (CHG), then set the LENS COVER switch to CLOSE.

Tip

- If you do not use your camcorder for a long time, remove the cassette and store it.
- You can also record movies by pressing REC START/STOP beside the LCD screen. It is useful for recording from a low angle or recording yourself in mirror mode.
- To press REC START/STOP beside the LCD screen, support the LCD panel with your hand.
- If you install a large capacity battery pack (NP-FP70/FP90) on your camcorder, we recommend recording with the LCD screen.

Indicators displayed during recording

The indicators will not be recorded on the tape. Date/time and the camera settings data (p. 37) will not be displayed during recording.

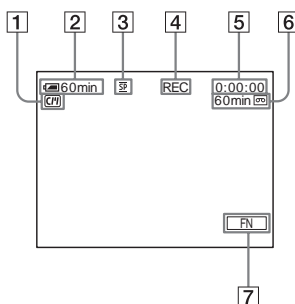

1 Indicators for Cassette Memory cassettes

2 Remaining battery

The indicated time may not be correct depending on the environment of use. When you opened or closed the LCD panel, it takes about 1 minute to display the correct remaining battery time.

3 Recording mode (SP or LP)

4 Recording status ([STBY] (standby) or [REC] (recording))

→ continued

5 **Tape photo recording/Time code or tape counter (hour: minute: second)**

6 **Recording capacity of the tape (p. 55)**

7 **Function button**

Notes

- Before changing the battery pack, slide the POWER switch up to OFF (CHG).
- In the default setting, when you do not operate the camcorder for more than about 5 minutes, the power will automatically turn off to prevent battery loss ([A.SHUT OFF], p. 60). To restart recording, slide the POWER switch until the CAMERA lamp lights up, and then press REC START/STOP.

Tips

- To ensure smooth transition on a tape from the last recorded scene to the next, note the following.
 - Do not remove the cassette. (The picture will be recorded continuously without a break even when you turn the power off.)
 - Do not record pictures in SP mode and LP mode on the same tape.
 - Avoid stopping then recording a movie in the LP mode.
- The recording time, date, and the camera settings data are recorded automatically on the tape without being displayed on the screen. You can view this information during playback if you set [DATA CODE] on the screen (p. 37).

Recording for a longer time

To record for a longer time

In the  (TAPE SET) menu, select [REC MODE], then [LP] (p. 55).

In the LP mode, you can record 1.5 times longer than you can when recording in the SP mode.

A tape recorded in the LP mode should be played back only on this camcorder.

Using zoom

You can choose zoom to magnification levels greater than 10 times, and from that point activate the digital zoom ([D ZOOM], p. 47).

Occasional use of the zoom is effective, but use it sparingly for best results.

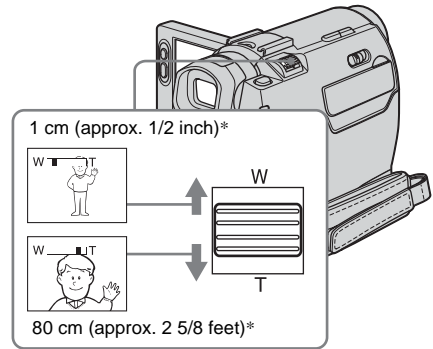

* The minimum distance required between your camcorder and the subject to get a sharp focus in that position of the lever.

Move the power zoom lever slightly for a slower zoom. Move it further for a faster zoom.

To record wider range of view

Move the power zoom lever towards W. The subject appears farther away (Wide angle).

To record closer view

Move the power zoom lever towards T. The subject appears closer (Telephoto).

Recording in mirror mode

You can turn the LCD panel towards the subject so that you and your subject can share the image being recorded. You can also utilize this function when recording yourself, to keep the attention of small children attracted to the camcorder while you record them.

Extend the viewfinder.

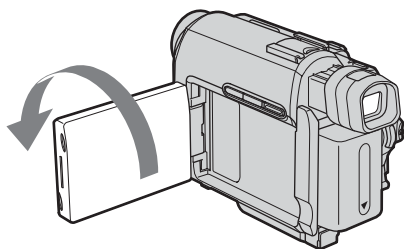

Open the LCD panel 90 degrees to the camcorder, then rotate it 180 degrees towards the subject.

A mirror-image of the subject appears on the LCD screen, but the picture will be normal when recorded.

Using the self-timer

With the self-timer, you can start recording after a delay of about 10 seconds.

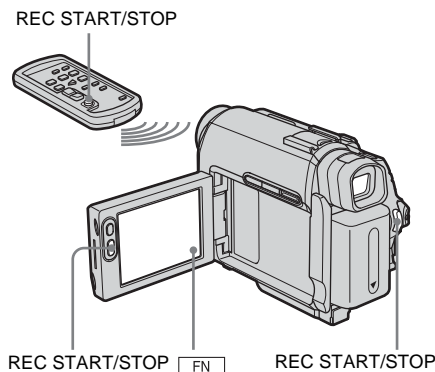

1 Touch  and select [PAGE2].

2 Touch [SELF TIMER].

3 Touch .

 appears.

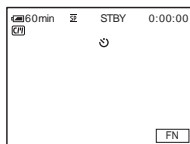

4 Press REC START/STOP.

You will hear a beep sound counting down for about 10 seconds.

The recording starts.

To stop recording, press REC START/STOP.

To cancel the count down

Press REC START/STOP.

To cancel the self-timer

Follow steps 1 and 2.

Recording still images – Tape photo recording

You can record still images. Before recording, follow steps 1 to 7 in “Getting started” (p. 11 - p. 20).

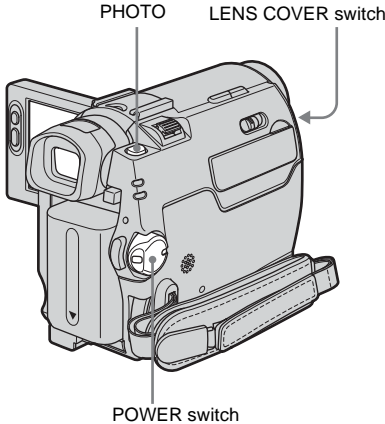

1 Set the LENS COVER switch to OPEN.

2 Open the LCD panel.

3 Slide the POWER switch until the CAMERA lamp lights up.

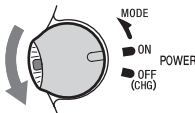

Slide the POWER switch while pressing the green button.

4 Press and hold PHOTO lightly.

You will hear a light beep sound and the picture becomes a still image. Recording does not start at this point.

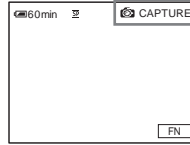

The indicator appears.

5 Press PHOTO fully.

A shutter sound is heard, and the image is recorded with sound for 7 seconds.

The still image is displayed on the screen until recording is completed.

To turn the power off

Slide the POWER switch up to OFF (CHG), then set the LENS COVER switch to CLOSE.

Note

-  appears when the tape photo recording does not work.

Tips

- You can record about 510 images in the SP mode and about 765 images in the LP mode on a 60 minutes tape.
- You can record still images using the self-timer recording (p. 23).

Recording with ease

– Easy Handycam

With this Easy Handycam operation, most of the camera settings are set to the automatic mode, only basic functions become available, and the screen font size increases for easy viewing. Even first time users can enjoy easy recording. Before recording, follow steps 1 to 7 in “Getting started” (p. 11 - p. 20).

Camera recording lamp EASY POWER switch

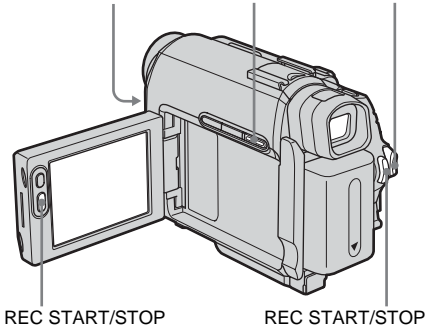

Tip

- When you touch MENU during Easy Handycam operation, only the available functions are displayed on the screen.

1 Set the LENS COVER switch to OPEN.

2 Open the LCD panel.

3 Slide the POWER switch to select the CAMERA mode.

You can record only movies.

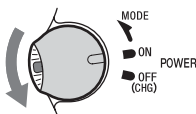

Slide the POWER switch while pressing the green button.

4 Press EASY.

EASY lights up in blue.

Easy Handycam
operation
ON

5 Press REC START/STOP.

Recording starts. [REC] appears on the LCD screen and the Camera recording lamp lights up. Press REC START/STOP again to stop recording.

To turn the power off

Slide the POWER switch up to OFF (CHG), then set the LENS COVER switch to CLOSE.

To cancel Easy Handycam operation

Press EASY again.

Notes

- You cannot switch from/to Easy Handycam operation during recording.
- During Easy Handycam operation, you cannot connect the USB cable to your camcorder.
- You cannot use Easy Handycam operation together with USB Streaming.
- During Easy Handycam operation, the following buttons are not available:
 - LCD BACKLIGHT (p. 16)
 - BACK LIGHT (p. 26)
- All the settings return to their defaults during Easy Handycam operation. Previously made settings are restored when you exit Easy Handycam operation.

Adjusting the exposure

The exposure is adjusted automatically in the default setting.

Adjusting the exposure for backlit subjects

When your subject has its back to the sun or other light, you can adjust the exposure to prevent the subject from becoming shadowed.

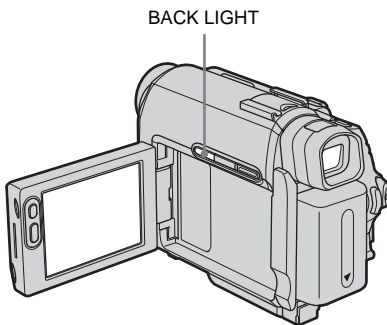

Press **BACK LIGHT** when the **POWER** switch is set to the **CAMERA** mode.

 appears.

To cancel the back light function, press **BACK LIGHT** again.

Note

- The back light function is canceled when you set [EXPOSURE] to [MANUAL] (p. 28) or select [SPOT METER] (p. 26).

Fixing the exposure for the selected subject – Flexible spot meter

You can adjust and fix the exposure to the subject, so that it is recorded in suitable brightness even when there is strong contrast between the subject and the background (such as subjects in the limelight on stage).

1 Slide the **POWER** switch to select the **CAMERA** mode.

2 Touch  to display [PAGE1].

3 Touch [SPOT METER].

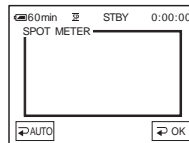

4 Touch the point you want to adjust and fix the exposure on the screen.

[SPOT METER] flashes while the camera is adjusting the exposure for the selected point.

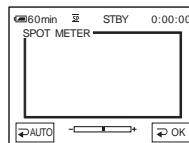

5 Touch .

6 Touch .

To return the setting to automatic exposure

Follow steps 1 to 3, then touch [AUTO] in step 4. Or set [EXPOSURE] to [AUTO] (p. 28).

Notes

- You cannot use the Flexible spot meter together with the NightShot plus function.
- If you set [PROGRAM AE], [SPOT METER] is automatically set to [AUTO].

Tip

- If you set [SPOT METER], [EXPOSURE] is automatically set to [MANUAL].

Adjusting the white balance manually

You can adjust the color balance to the brightness of the recording environment. The indicators in parentheses appear when the setting is selected.

[AUTO]

Select when you want to record with the white balance adjusted automatically.

[OUTDOOR] ()

Select when recording a sunset/sunrise, general night views, neon signs, fireworks, or when under daylight fluorescent lamps.

[INDOOR] ()

Select when recording at a party or in studios where lighting conditions change quickly. And also, select when under video lamps such as those in a studio, under sodium lamps, mercury lamps or warm white fluorescent lamps.

[ONE PUSH] ()

Select when you want to record with the white balance adjusted depending on the light source.

1 Slide the **POWER** switch to select the **CAMERA** mode.

2 Touch [] to display [PAGE1].

3 Touch [WHT BAL].

4 Touch the desired effect.

When you touch [ONE PUSH]

- 1** Frame a white object such as a piece of paper filling the screen under the same lighting conditions as you will shoot the subject.
- 2** Touch [].
 flashes quickly.
When the white balance has been adjusted and stored in the memory, the indicator stops flashing.

5 Touch [].

6 Touch [].

Notes

- You cannot use the white balance together with the NightShot plus function.
- The setting returns to [AUTO] when you disconnect the power source from your camcorder for more than 5 minutes.
- Do not shake or strike the camcorder while flashes quickly.
- When flashes slowly, the white balance is not set or was not able to be set.
- If keeps flashing even when you touch [], set [WHT BAL] to [AUTO].

Tips

- For better color balance adjustment when [WHT BAL] is set to [AUTO], aim your camcorder at a nearby white object for about 10 seconds after setting the POWER switch to CAMERA when:
 - You remove the battery pack for replacement.
 - You bring your camcorder outdoors from inside the house while using fixed exposure, or bring your camcorder in from outside.
- Redo the [ONE PUSH] procedure when:
 - You changed the [PROGRAM AE] settings when [WHT BAL] is set to [ONE PUSH].
 - You brought your camcorder outdoors from inside the house, or vice versa.
- Set [WHT BAL] to [AUTO] or [ONE PUSH] under white or cool white fluorescent lamps.

Adjusting the exposure manually

You can fix the brightness of a picture at the best exposure. When recording indoors on a clear day, for instance, you can avoid backlight shadows on people next to the window by manually fixing the exposure to that of the wall side of the room.

To return the setting to automatic exposure

Follow steps 1 to 3, then select [↔ AUTO] in step 4.

Note

- You cannot use the manual exposure together with the NightShot plus function.

1 Slide the **POWER** switch to select the **CAMERA** mode.

2 Touch [FN] to display [PAGE1].

3 Touch [EXPOSURE].

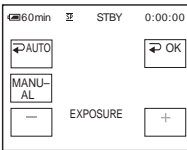

4 Touch [MANUAL].

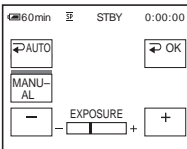

5 Adjust the exposure by touching [−] (dim)/ [+] (bright), then touch [↔OK].

6 Touch [X].

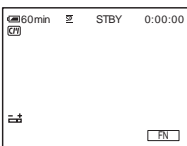

Recording in dark places – NightShot plus

You can record subjects in dark places (such as when capturing the face of your baby sleeping) with this function.

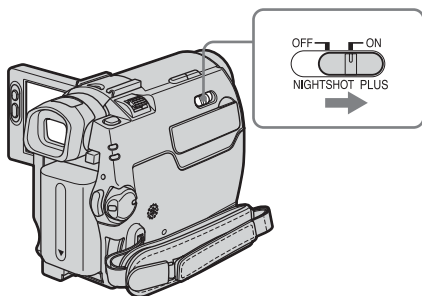

Set the NIGHTSHOT PLUS switch to ON.

 and "NIGHTSHOT PLUS" appear.

To cancel NightShot plus, set the NIGHTSHOT PLUS switch to OFF.

Notes

- Do not use the NightShot plus function in bright places. This may cause a malfunction.
- You cannot use the NightShot plus function together with:
 - [PROGRAM AE]
 - Manual exposure
 - Flexible spot meter
 - White balance
- Adjust the focus manually when it is hard to focus automatically.
- Do not cover the infrared port with your fingers or other objects. Remove the conversion lens (optional) if it is attached.
- Depending on the shooting conditions or circumstances, colors may not be reproduced properly.

Tip

- If you record subjects in complete darkness, set [N.S.LIGHT] to [ON] in the menu setting. The maximum shooting distance using the NightShot Light is about 3 meters (10 feet). If you record subjects in dark places (such as night scene or in moonlight), set [N.S.LIGHT] to [OFF] in the menu setting. You can make image color deeper (p. 49).

Adjusting the focus

The focus is adjusted automatically in the default setting.

Adjusting the focus for an off-center subject – SPOT FOCUS

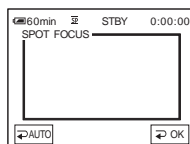

You can select and adjust the focal point to aim it at a subject not located in the center of the screen.

- 1 Slide the **POWER** switch to select the **CAMERA** mode.
- 2 Touch  to display [PAGE1].
- 3 Touch [SPOT FOCUS].



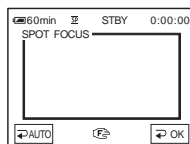

- 4 Touch the subject for which you want to adjust the focus on the screen. [SPOT FOCUS] flashes while the camera is adjusting the focus.  appears.



- 5 Touch  .
- 6 Touch  .

→ continued

To adjust the focus automatically

Follow steps 1 to 3, then touch [ AUTO] in step 4. Or, set [FOCUS] to [ AUTO] (p. 30).

Note

- You cannot use the SPOT FOCUS function together with [PROGRAM AE].

Tip

- If you set [SPOT FOCUS], [FOCUS] is automatically set to [MANUAL].

Adjusting the focus manually

You can adjust the focus manually according to the recording conditions.

Use this function in the following cases.

- To record a subject behind a window covered with raindrops.
- To record horizontal stripes.
- To record a subject with little contrast between the subject and its background.
- When you want to focus on a subject in the background.

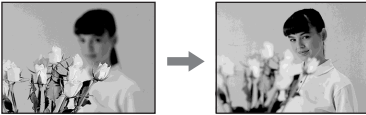

- To record a stationary subject using a tripod.

1 Slide the **POWER** switch to select the **CAMERA** mode.

2 Touch  to display [PAGE1].

3 Touch [FOCUS].

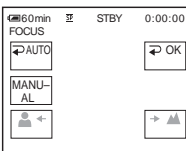





4 Touch [MANUAL].

 appears.

5 Touch  or  to adjust the focus.

 : To focus on close subjects.

 : To focus on distant subjects.

 changes to  when the focus cannot be adjusted any further.  changes to  when the focus cannot be adjusted any closer.

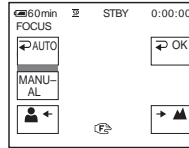

Tips for focusing manually

- It is easier to focus on the subject when you use the zoom function. Move the power zoom lever towards T (telephoto) to adjust the focus, and then, towards W (wide angle) to adjust the zoom for recording.
- When you want to record a close-up image of a subject, move the power zoom lever towards W (wide angle) to fully magnify the image, then adjust the focus.

6 Touch  .

7 Touch  .

To adjust the focus automatically

Follow steps 1 to 3, then touch [ AUTO] in step 4.

Recording a picture using various effects

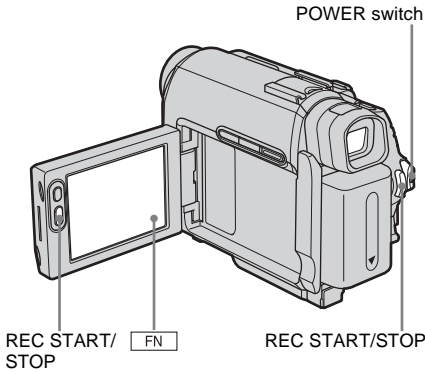

Fading in and out of a scene – FADER

You can add the following effects to currently recording pictures.



[BLACK] (black fader)

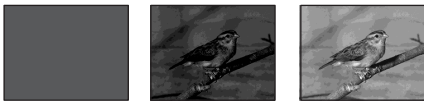

[WHITE] (white fader)



[MOSC. FADER] (mosaic fader)



[MONOTONE]

When fading in, the picture gradually changes from black-and-white to color.
When fading out, the picture gradually changes from color to black-and-white.

- 1 Slide the **POWER** switch to select the **CAMERA** mode.
- 2 Touch **[FN]** to display **[PAGE1]** in the standby mode (to fade in) or during recording (to fade out).
- 3 Touch **[FADER]**.

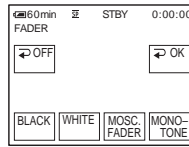

- 4 Touch the desired effect, then touch **[OK]**.
- 5 Touch **[X]**.

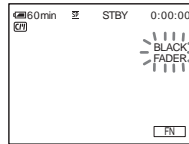

- 6 Press **REC START/STOP**.
The fader indicator stops flashing and disappears when the fade is complete.

To cancel the operation

In step 3, touch **[OFF]**.

Note

- You cannot use the FADER function together with:
 - Tape photo recording
 - [FRAME REC] (Frame recording)
 - [INT.REC] (Interval recording)

Searching for the starting point

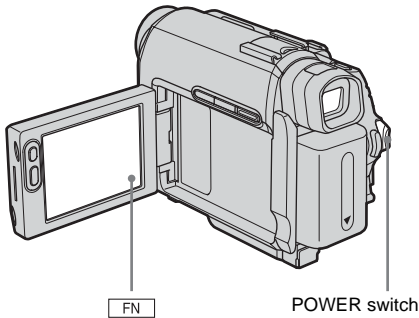

Searching for the last scene of the most recent recording – END SEARCH

This function is handy when you have played back the tape, for example, but want to start recording right after the most recently recorded scene. When you use a cassette without Cassette Memory, the END SEARCH function will not work once you eject the cassette after you have recorded on the tape. If you use a cassette with Cassette Memory, it will function even when you have ejected the cassette.

1 Slide the POWER switch to select the CAMERA mode.

2 Touch  to display [PAGE1].

3 Touch [END SCH].

The last scene of the most recent recording is played back for about 5 seconds, and the camcorder enters the standby mode at the point where the last recording has finished.

4 Touch .

To cancel the operation

Touch [END SCH] again.

Note

- The END SEARCH function will not work correctly when there is a blank section between recorded sections on the tape.

Tip

- When the PLAY/EDIT mode is selected, you can do this operation.



Searching manually – EDIT SEARCH

You can search for the start point while viewing the pictures on the screen. The sound is not played back during the search.

1 Slide the POWER switch to select the CAMERA mode.



2 Touch  to display [PAGE1].

3 Touch MENU.

4 Select , then select [EDITSEARCH] with  / , then touch [EXEC].

5 Select [ON], then touch [EXEC].

6 Touch .

7 Keep touching  /  (to go backward) /  (to go forward) and release it at the point where you want to start recording.

Reviewing the most recently recorded scenes – Rec review

You can view a few seconds of the scene recorded just before you stopped the tape.

1 Slide the **POWER** switch to select the **CAMERA** mode.

2 Touch **[FN]** to display [PAGE1].

3 Touch **MENU**.

4 Select **[CAMERA SET]**, then select **[EDITSEARCH]** with **[↓]** / **[↑]**, then touch **[EXEC]**.

5 Select **[ON]**, then touch **[EXEC]**.

6 Touch **[X]**.

7 Touch **[G/-]** once.

The last few seconds of the most recently recorded scene are played back. Then, your camcorder is set to the standby mode.

Viewing pictures recorded on a tape

Make sure you have a recorded tape inserted into your camcorder.

Some of the operations are possible using the Remote Commander or using the touch panel.

When you want to play back recordings on your TV, see page 39.

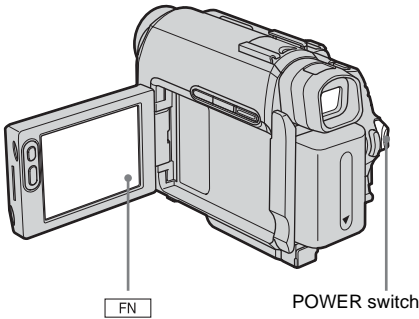

Tip

- Performing Easy Handycam operation, even first time users can play back easily. For details, see page 36.

1 Open the LCD panel.

2 Slide the POWER switch repeatedly until the PLAY/EDIT lamp lights up.

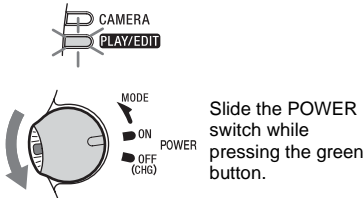

3 Touch (rewind) to go to the point you want to view.

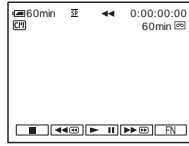

4 Touch (play) to start playback.

To adjust the volume

- Touch to display [PAGE1].
- Touch [VOL].
- Adjust the volume by touching (decrease) / (increase), then touch .
- Touch .

To stop playback

Touch (stop).

To pause

Touch (pause) during playback. Touch it again to restart the playback.

Playback stops automatically when the pause mode continues for more than 5 minutes.

To fast forward or rewind

Touch (fast forward) or (rewind) in stop mode.

To review movies on the viewfinder

Close the LCD panel. Then, extend the viewfinder.

Indicators displayed during playback

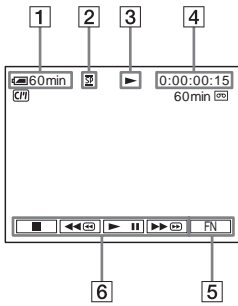

- 1 Remaining battery time
- 2 Recording mode (SP or LP)
- 3 Tape transport indicator
- 4 Time code (hour: minute: second: frame) or tape counter (hour: minute: second)
- 5 Function button
- 6 Video operation buttons

Playing back in various modes

To fast forward or rewind during playback – Picture search

Keep touching (fast forward) or (rewind) during playback.

To resume normal playback, release the button.

To view the picture while fast forwarding or rewinding – Skip scan

Keep touching (fast forward) or (rewind) while fast forwarding or rewinding the tape.

To resume fast forwarding or rewinding, release the button.

To play back in various modes

You will not hear the recorded sound. Also, you may see mosaic-like images of the previously played picture remaining on the screen.

- 1 Touch and select [PAGE3] during playback or playback pause.
- 2 Touch [V SPD PLAY].

3 Select a playback mode.

To return to the normal playback mode, touch (play/pause) twice (once from frame playback).

To	Touch
change the playback direction*	(frame) during playback.
play back slowly**	[SLOW] during playback. To reverse direction 1 Touch (frame). 2 [SLOW].
play back 2 times faster (double speed)	[] (double speed) during playback. To reverse direction 1 Touch (frame). 2 [] (double speed).
play back frame by frame	[] (frame) during playback pause. To reverse direction, touch (frame) again during frame playback.

*Horizontal lines may appear at the top, bottom, or in the center of the screen. This is not a malfunction.

**Pictures output from the DV Interface cannot be played back smoothly in slow mode.

- 4 Touch [RET.], then [X] .

Playing back with ease – Easy Handycam

Easy Handycam operation allows easy playback for even first time users by providing only the basic functions for playback. Also, the screen font size increases for easy viewing. Make sure you have a recorded tape inserted into your camcorder.

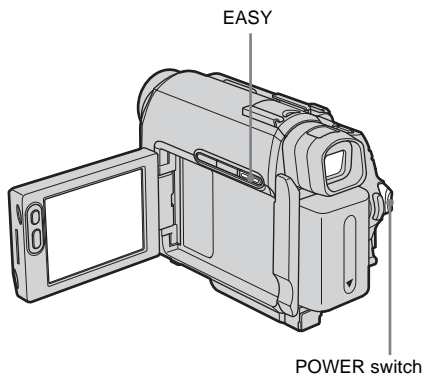

Tip

- When you touch **FN** and **MENU** during Easy Handycam operation, only the available functions are displayed on the screen.

1 Open the LCD panel.

2 Slide the **POWER** switch repeatedly to select the **PLAY/EDIT** mode.

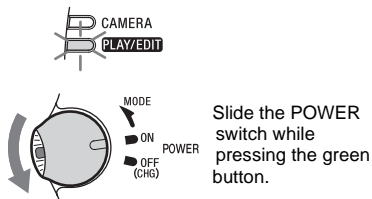

3 Press **EASY**.

EASY lights up in blue.



4 **Play back a tape.**

The following buttons can be operated.

- ▶|| (play/pause) / ▶▶ (fast forward)
- (stop) / ◀◀ (rewind)

You can operate these operations and **SLOW** ▶▶ on the Remote Commander.

To cancel Easy Handycam operation

Press **EASY** again.

Notes

- During Easy Handycam operation, you cannot connect the USB cable to your camcorder.
- You cannot use Easy Handycam operation together with USB Streaming.

Various playback functions

You can display the recorded date and camera setting data.

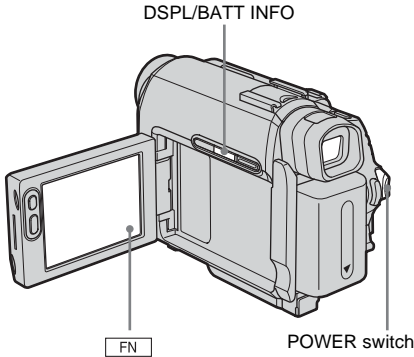

Displaying the screen indicators

You can choose to display the time code, tape counter, and other information on the screen.

Press DSPL/BATT INFO.

The indicators appear/disappear as you press the button.

Tips

- You can display the screen indicators by pressing **DISPLAY** on the Remote Commander.
- You can display the screen indicators during playback on a TV. Select **[ETC]** (OTHERS), **[DISPLAY]**, then **[V-OUT/LCD]** (p. 61).

Displaying the date/time and camera settings data – Data code

During playback, you can view the date/time data (**[DATE/TIME]**) and the camera settings data (**[CAM DATA]**) that are automatically recorded while recording pictures on a tape.

- 1 Slide the **POWER** switch repeatedly to select the **PLAY/EDIT** mode.
- 2 Touch **[FN]** and select **[PAGE2]** during playback or playback pause.
- 3 Touch **[DATA CODE]**.

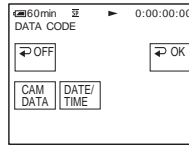

- 4 Select **[CAM DATA]** or **[DATE/TIME]**, then touch **[OK]**.

- 5 Touch **[X]**.

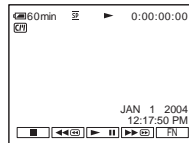

To hide the date/time or the camera settings data

Follow steps 2 and 3, and select **[OFF]** in step 4.

Camera settings data display

In the date/time data display, the date and time is displayed in the same area.

If you record the picture without setting the clock, [--- -- ----] and [--:--:--] will appear.

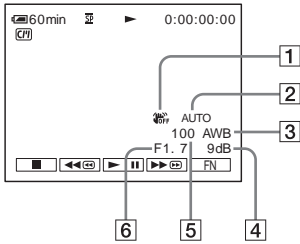

- 1 SteadyShot off**
- 2 Exposure**
- 3 White balance**
- 4 Gain**
- 5 Shutter speed**
- 6 Aperture value**

Playing the picture on a TV

Connect your camcorder to a TV using the supplied A/V connecting cable as shown in the following illustration. Connect the supplied AC Adaptor to the wall outlet for the power supply (p. 14). Refer also to the instruction manuals supplied with the devices to be connected. To copy to another tape, see page 63.

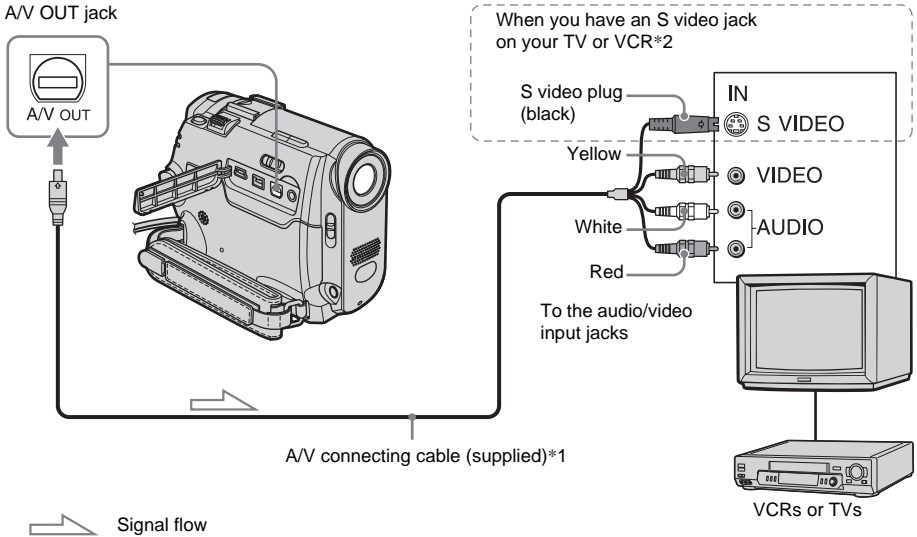

Playback

- *1 The supplied A/V connecting cable has a video plug and an S video plug for the video connection.
- *2 This connection produces higher quality DV format pictures. When there is an S video jack on the device to be connected, connect the S video plug to that jack instead of using the yellow video plug. The audio will not be output when you connect with the S video plug alone.

When your TV is connected to a VCR

Connect your camcorder to the LINE IN input on the VCR using the A/V connecting cable. Set the input selector on the VCR to LINE.

When your TV is monaural (When your TV has only one audio input jack)

Connect the yellow plug of the A/V connecting cable to the video input jack and connect the white or the red plug to the audio input jack of your TV or VCR.

When you want to play the sound in monaural mode, use a connecting cable (optional) for that purpose.

Locating a scene on a tape for playback

Searching quickly for a desired scene – Zero set memory

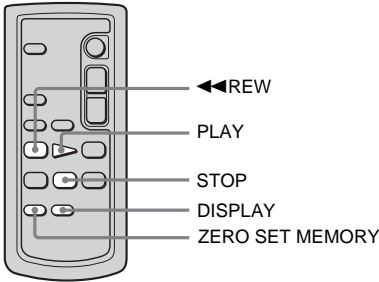

- 1 During playback, press **ZERO SET MEMORY** on the Remote Commander at the point you want to locate later on.

The tape counter is reset to “0:00:00” and →0← appears on the screen.

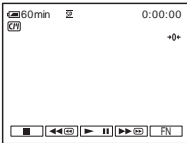

If the tape counter is not displayed, press **DISPLAY** on the Remote Commander.

- 2 Press **STOP** when you want to stop playback.

- 3 Press **←REW**.

The tape stops automatically when the tape counter reaches “0:00:00.”

- 4 Press **PLAY**.

The playback starts from the point designated “0:00:00” on the tape counter.

To cancel the operation

Press **ZERO SET MEMORY** on the Remote Commander again.

Notes

- There may be a discrepancy of several seconds between the time code and the tape counter.
- Zero set memory will not function correctly if there is a blank section between recorded sections on the tape.

Searching for a scene using Cassette Memory – Title search

You can locate a scene where you have added a title (p. 52).

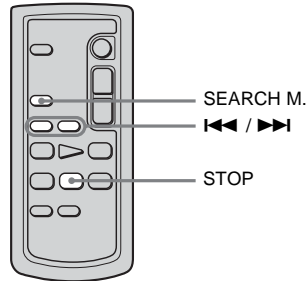

- 1 Slide the **POWER** switch repeatedly to select the **PLAY/EDIT** mode.

- 2 Press **SEARCH M.** on the Remote Commander repeatedly to select **[TITLE SEARCH]**.

- 3 Press **I<<** (previous)/**I>>** (next) on the Remote Commander to select a title that you want to play.

Playback starts automatically from the selected title.

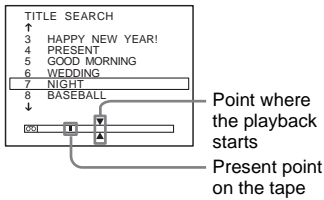

2 Press **SEARCH M.** on the Remote Commander repeatedly to select **[DATE SEARCH]**.

3 Press **◀◀** (previous)/**▶▶** (next) on the Remote Commander to select a recording date.

When your cassette has **Cassette Memory**, you can select the recording date itself. When your cassette does not have **Cassette Memory**, you can select the previous or the next date of the present point on the tape. Playback starts automatically from the point where the date changes.

Screen example (when the cassette has **Cassette Memory**):

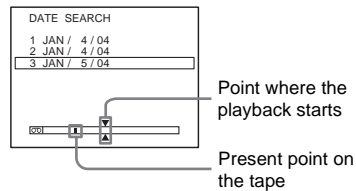

To cancel the operation

Press **STOP** on the Remote Commander.

⚡ Notes

- You cannot use Title search when **[CM SEARCH]** is set to **[OFF]** on the **[CM]** (**CM SET**) menu (it is set to **[ON]** by default) (p. 54).
- Title search will not function correctly when there is a blank section between recorded sections on the tape.

Searching for a scene by date of recording – Date search

When you are using a cassette with **Cassette Memory**, you can locate a scene by the recording date (**[CM SEARCH]** is set to **[ON]** by default). When you are using a cassette that does not have **Cassette Memory**, you can locate the point where the recording date changes.

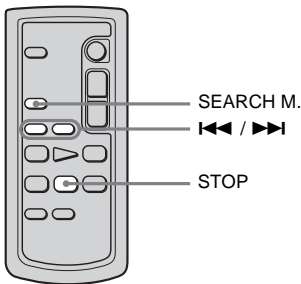

To cancel the operation

Press **STOP** on the Remote Commander.

⚡ Notes

- If one day's recording is less than 2 minutes, your camcorder may not accurately find the point where the recording date changes.
- Date search will not function correctly when there is a blank section between recorded sections on the tape.
- You can record date/time data for up to 6 days. When you have recorded for more than 7 days on a tape, locate the date without using the **Cassette Memory**. To turn off the **Cassette Memory**, select **[CM]** (**CM SET**), **[CM SEARCH]**, and then **[OFF]** (p. 54).

Searching for a still image – Photo search

When you are using a cassette with **Cassette Memory**, you can locate the still image by

→ continued

1 Slide the **POWER** switch repeatedly to select the **PLAY/EDIT** mode.

choosing the recording date on the screen. ([CM SEARCH] is set to [ON] by default).
 When you are using a cassette that does not have Cassette Memory, your camcorder searches the still image automatically regardless of the recording date.

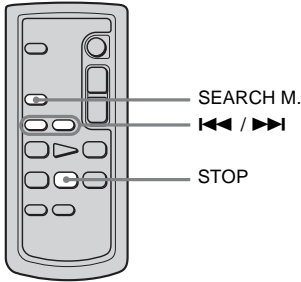

1 Slide the **POWER** switch repeatedly to select the **PLAY/EDIT** mode.

2 Press **SEARCH M.** on the Remote Commander repeatedly to select [**PHOTO SEARCH**].

3 Press **◀ (previous) / ▶ (next)** on the Remote Commander to select the date or photo for playback.

When your cassette has Cassette Memory, you can select the recorded date.

When your cassette does not have Cassette Memory, your camcorder selects the still image before and behind the current point of the tape.

Playback of the photo starts automatically at the selected scene.

To cancel the operation

Press **STOP** on the Remote Commander.

Note

- Photo search will not function correctly when there is a blank section between recorded sections on the tape.

Playing back still images in sequence – Photo scan

You can also locate still images one after another and display each images for 5 seconds automatically.

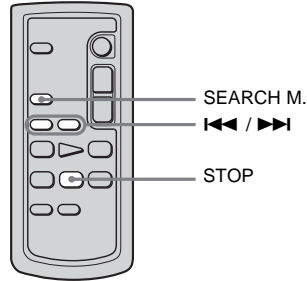

1 Slide the **POWER** switch repeatedly to select the **PLAY/EDIT** mode.

2 Press **SEARCH M.** on the Remote Commander repeatedly to select [**PHOTO SCAN**].

3 Press **◀ (previous) / ▶ (next)** on the Remote Commander.

Each photo will be played back for about 5 seconds.

To cancel the operation

Press **STOP** on the Remote Commander.

Note

- Photo scan will not function correctly when there is a blank section between recorded sections on the tape.

►Advanced operations

Customizing Your Camcorder

Changing the menu settings

You can change various settings or make detailed adjustments using the menu items displayed on the screen.

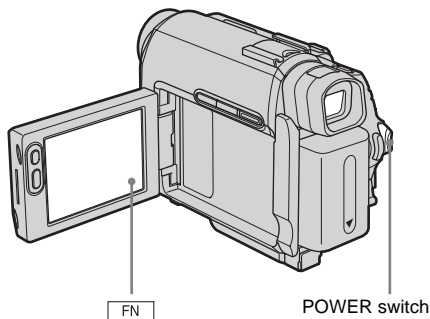

- CAMERA SET (p. 47)
- VCR SET (p. 50)
- LCD/VF SET (p. 51)
- CM SET (p. 52)
- TAPE SET (p. 55)
- SETUP MENU (p. 58)
- OTHERS (p. 60)

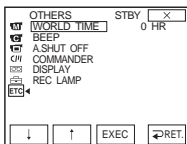

- 5 Select the desired item with / , then touch [EXEC].

The available menu items vary depending on the power mode of your camcorder. The unavailable items will not be displayed.

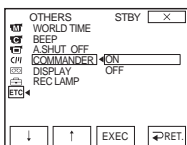

- 6 Select the desired setting with / , then touch [EXEC].

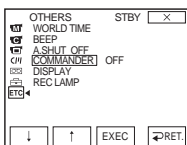

- 1 Turn on the power (p. 15).

- 2 Touch to display [PAGE1].

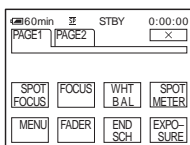

- 3 Touch MENU to display the menu.

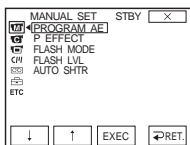

- 4 Select the icon of the desired menu with / , then touch [EXEC].

MANUAL SET (p. 44)

- 7 Touch (close) to hide the menu screen.

You can go back to the previous screen each time you touch [RET].

Using the (MANUAL SET) menu

– PROGRAM AE/P EFFECT, etc.





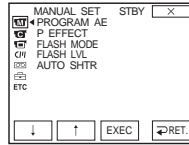







You can select items listed below on the MANUAL SET menu. To select items, see “Changing the menu settings” (p. 43). The default settings are marked with ▷. The indicators in parentheses appear when the

setting is selected. The settings you can adjust vary depending on the power mode of your camcorder. The screen shows the items you can operate at the moment. Unavailable items will be grayed out.



PROGRAM AE

You can record pictures easily in a situation that requires various techniques by selecting the following settings.

▷ AUTO	Select this when not using PROGRAM AE.	
SPOTLIGHT* (spotlight) ()	Select to prevent people's faces from appearing excessively white when subjects are lit by strong light, such as in a theater or at a wedding.	
PORTRAIT (soft portrait) ()	Select to bring out the subject such as people or flowers while creating a soft background.	
SPORTS* (sports lesson) ()	Select to minimize shake when shooting fast-moving subjects such as in tennis or golf.	
BEACH&SKI* (beach & ski) ()	Select to prevent people's faces from appearing dark in strong light or reflected light, such as at a beach in midsummer or on a ski slope.	
SUNSETMOON** (sunset & moon) ()	Select to maintain the atmosphere of situations such as sunsets, general night views, fireworks, and neon signs.	
LANDSCAPE** (landscape) ()	Select when shooting distant subjects such as mountains. This setting also prevents your camcorder from focusing on glass or metal mesh in windows that comes in between the camcorder and the subject.	

* Your camcorder is adjusted to focus only on subjects in the middle to far distance.





**Your camcorder is adjusted to focus only on distant subjects.

Note

- When you set the NIGHTSHOT PLUS switch to ON, [PROGRAM AE] does not work. (The indicator flashes.)

P EFFECT

You can add special effects (such as films) to a picture before or after recording. **[P+]** appears when the effect is selected.

▷OFF	Select when not using the Picture effect setting.	
NEG.ART	Select to record/play the picture with the color and brightness of the picture reversed.	
SEPIA	Select to record/play the picture appearing in sepia.	
B&W	Select to record/play the picture appearing in monochrome (black-and-white).	
SOLARIZE	Select to record/play the picture looking like an illustration with strong contrast.	
PASTEL	Select to record the picture looking like a pale pastel drawing. (This effect is not available during playback.)	
MOSAIC	Select to record the picture appearing mosaic-patterned. (This effect is not available during playback.)	

Note

- You cannot add effects to externally input pictures. Also, you cannot output pictures edited with Picture effect via the **[i]** DV Interface.

Tip

- You can copy pictures edited using Picture effect to another tape (p. 63).

FLASH MODE

Note that these settings will not function with external flashes that do not support the following settings.

▷ON	To trigger the flash (optional) regardless of the brightness of the surroundings.
AUTO	To trigger the flash (optional) automatically.

→continued

FLASH LVL

Note that these settings will not function with external flashes that do not support the following settings.

HIGH	To make the flash (optional) level higher than normal.
▷NORMAL	To use the normal setting.
LOW	To make the flash (optional) level lower than normal.

Note

- The setting returns to [NORMAL] when you disconnect the power source from your camcorder for more than 5 minutes.

AUTO SHTR

▷ON	Select to automatically activate the electronic shutter to adjust the shutter speed when recording in bright conditions.
OFF	Select when recording without using the electronic shutter.

Using the (CAMERA SET) menu

– D ZOOM/16:9WIDE, etc.

You can select items listed below on the CAMERA SET menu. To select items, see “Changing the menu settings” (p. 43). The default settings are marked with ▷. The indicators in parentheses appear when the

setting is selected. The settings you can adjust vary depending on the power mode of your camcorder. The screen shows the items you can operate at the moment. Unavailable items will be grayed out.

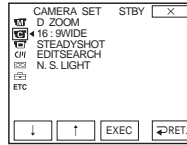

D ZOOM

You can select the maximum zoom level in case you want to zoom to a level greater than 10 times while recording on a tape. Note that the image quality decreases when you are using the digital zoom. This function is useful when recording enlarged pictures of a distant subject, such as a bird.



The right side of the bar shows the digital zooming zone. The zooming zone appears when you select the zooming level.

▷OFF	Select to deactivate the digital zoom. Up to 10 times zoom is performed optically.
20 ×	Select to activate the digital zoom. 10 times through 20 times zoom is performed digitally.
120 ×	Select to activate the digital zoom. 10 times through 120 times zoom is performed digitally.

16:9WIDE

You can record a 16:9 wide picture on the tape to watch on a 16:9 wide-screen TV ([16:9WIDE] mode).

With this function [ON], your camcorder offers even wider angles when you move the power zoom lever to the “W” side than recording in [OFF].

When you connect your camcorder to the S video input jack of a TV compatible with the ID-1/ID-2 system and play the tape, the TV switches to full mode automatically.

Refer also to the instruction manuals supplied with your TV.

→continued

When viewed on the LCD screen/viewfinder

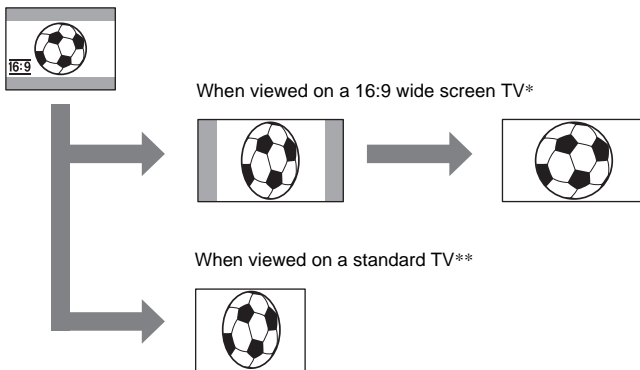

* The picture appears in full screen when the wide-screen TV switches to full mode.

** Played in 4:3 mode. When you play a picture in the wide mode, it appears as you have seen on the LCD screen or in the viewfinder.

▷OFF	Standard setting (to record pictures to play back on a 4:3 TV). The recorded picture will not be wide.
ON ()	Select to record a picture to be played back on a 16:9 wide TV. The recorded picture will be played in full mode when you connect to your TV compatible with ID-1/ID-2 systems.

Tips



- The ID-1 system sends aspect ratio information (16:9, 4:3, or letter box) by inserting signals between video signals.
- The ID-2 system sends a copyright protection signal with the ID-1 signals inserted between video signals in an analog connection.

STEADYSHOT

You can select this function to compensate for camera-shake.

▷ON	Standard setting (enable the SteadyShot function).
OFF ()	Select to deactivate the SteadyShot function. Select to shoot a stationary subject with a tripod, or when using a conversion lens (optional). Natural pictures are produced.

EDITSEARCH

▷OFF	Select not to display  / - or + on the LCD screen.
ON	Select to display  / - and + on the LCD screen, and use the EDITSEARCH function and Rec review (p. 32).

N.S.LIGHT

When using the NightShot plus function to record, you can record clearer pictures by using the NightShot Light to emit infrared rays (invisible).

▷ON	Select to use the NightShot Light (p. 29).
OFF	Select to disable the NightShot Light (p. 29).

Using the (VCR SET) menu – HiFi SOUND/AUDIO MIX

You can select items listed below on the VCR SET menu. To select these items, see “Changing the menu settings” (p. 43). The default settings are marked with ▷. The indicators in parentheses appear when the

setting is selected. The settings you can adjust vary depending on the power mode of your camcorder. The screen shows the items you can operate at the moment. Unavailable items will be grayed out.

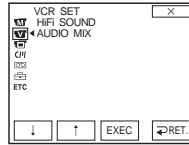

HiFi SOUND

You can select how to play back audio recorded on a tape in stereo mode.

▷STEREO	Select to play back a stereo tape or dual sound track tape with main and sub sound.
1	Select to play back a stereo tape with the left channel sound or a dual sound track tape with main sound.
2	Select to play back a stereo tape with the right channel sound or a dual sound track tape with sub sound.

Notes

- You can play back a dual sound track cassette on this camcorder. However, you cannot record a dual sound track on this camcorder.
- The setting returns to [STEREO] when you disconnect the power source from your camcorder for more than 5 minutes.

AUDIO MIX

You can adjust the audio balance between the originally recorded sound ([ST1]) and sound added afterwards ([ST2]) on the tape (p. 70).

Notes

- You cannot adjust sound recorded in 16 bit audio mode.
- Only the originally recorded sound will be heard when you disconnect the power source from your camcorder for more than 5 minutes.

Using the (LCD/VF SET) menu

– LCD B.L./LCD COLOR/VF B.L.

You can select items listed below on the LCD/ VF SET menu. To select items, see “Changing the menu settings” (p. 43).

The default settings are marked with ▷. The screen shows the items you can operate at the moment. Unavailable items will be grayed out.

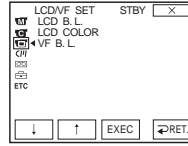

LCD B.L.



You can adjust the brightness of the LCD screen’s backlight. The recorded picture will not be affected by this setting.

▷BRT NORMAL	Standard brightness.
BRIGHT	Select to brighten the LCD screen.

Notes

- When you connect your camcorder to outside power sources, [BRIGHT] is automatically selected for the setting.
- When you select [BRIGHT], the battery life is reduced by about 10 percent during recording.

LCD COLOR

Touch  /  to adjust the color on the LCD screen. The recorded picture will not be affected by this setting.

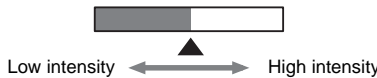

VF B.L.

You can adjust the brightness of the viewfinder. The recorded picture will not be affected by this setting.

▷BRT NORMAL	Standard brightness.
BRIGHT	Select to brighten the viewfinder screen.

Notes

- When you connect your camcorder to outside power sources, [BRIGHT] is automatically selected for the setting.
- When you select [BRIGHT], the battery life is reduced by about 10 percent during recording.

Using the (CM SET) menu

– TITLE/TAPE TITLE/ERASE ALL, etc.

You can select items listed below on the CM SET menu. To select items, see “Changing the menu settings” (p. 43).



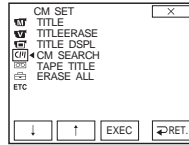

The default settings are marked with ▷. The settings you can adjust vary depending on the power mode of your camcorder. The screen shows the items you can operate at the moment. Unavailable items will be grayed out.



TITLE

Any titles you have superimposed using this camcorder can only be viewed on a ^{Mini DV} video cassette device with the index titler function. If you superimpose a title, you will be able to search for it using Title search. You can superimpose up to about 20 titles (about 5 letters per title) on a cassette with Cassette Memory. Note, however, that only 11 titles can be recorded when other data (6 date/time data/1 cassette label/12 photo data) is recorded.

1 Select a desired title from the displayed titles (2 original titles that you have created before and the preset titles that have been stored in your camcorder). You can create original titles (up to 2 types of title of within 20 characters each) in the following procedure.

- ❶ Select [CUSTOM 1””] or [CUSTOM 2””] with  / , then touch [EXEC].**
- ❷ Select [CREATE/EDIT] with  / , then touch [EXEC].**
- ❸ Touch the button repeatedly to select the desired character on the button.**

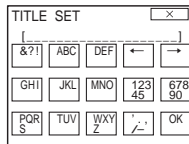

To erase a character: Touch .

To insert a space: Touch .

- ❹ Touch  to move to select the next character, and enter the character in the same manner.**
 - ❺ When you have finished entering characters, touch [OK].**
- 2 Select the title you want to insert, then touch [EXEC].**
To insert an original title, select [OK] and touch [EXEC].
- 3 Touch [COLOR], [SIZE], [POS↓] or [POS↑] as necessary to select a desired color, size, or position.**

Color

white → yellow → violet → red → cyan → green → blue

Size

small ↔ large

(You can only select the small size when you are entering more than 13 characters.)

Position

You can select from 8 to 9 choices.

4 Touch [TITLE OK], then touch [SAVE TITLE].

During playback, playback pause, or recording

[TITLE SAVE] is displayed on the screen for about 5 seconds and the title is set.

During recording standby

[TITLE] appears. When you press REC START/STOP to start recording, [TITLE SAVE] is displayed on the screen for about 5 seconds, and the title is set.





⚙ Notes

- The point you superimposed the title may be detected as an index signal when searching a recording with other video device.
- When you are using your camcorder on the battery pack and do not operate it for 5 minutes, the power automatically goes off as the default setting. If you may take 5 minutes or longer to enter characters, set [A.SHUT OFF] on the  (OTHERS) menu to [NEVER] (p. 60). The power will not be turned off. Even though the power goes off, the characters you have entered remain stored in memory. Turn the power back on, then start again from step 1 to continue superimposing the title.

💡 Tip

- To change a created title, select the title in step 1, touch [EXEC] and select [CREATE/EDIT], then touch [EXEC]. Then, reselect the characters again.

TITLEERASE

- 1 Select the title that you want to delete using  /  , then touch [EXEC].**
- 2 Confirm the title is the one you want to delete, then touch .**
To cancel the operation, touch [CANCEL].
- 3 Touch .**

TITLE DSPL

You can view the title when you play back the picture.

▷ON	Select to display the title when a scene superimposed with a title appears.
OFF	Select when you do not want to display the title.

→ continued

CM SEARCH

▷ON	Select to search for a scene, title, etc. using Cassette Memory (p. 40 - 42).
OFF	Select to search without using Cassette Memory.

TAPE TITLE



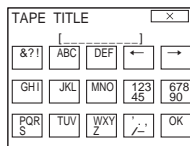

You can label a cassette with Cassette Memory (up to 10 letters). The label will be displayed for approximately 5 seconds when you select the CAMERA mode and insert a cassette, or when you select the PLAY/EDIT mode. Up to 4 titles will be displayed at the same time if the cassette has titles superimposed.

- 1 Touch the button repeatedly to select the desired character on the button.





To erase a character: Touch .

To insert a space: Touch .



- 2 Touch  to move  to select the next character, and enter the character in the same manner.
- 3 When you have finished entering characters, touch .
- 4 Touch .

Tips

- To erase the label you have created, touch  repeatedly to erase the characters, then touch .
- To change the label you have created, insert the cassette into your camcorder and go through the procedure from step 1.

ERASE ALL

You can delete all data such as date, title, cassette label, and photo data saved in the Cassette Memory at one time.

- 1 Select , then touch **[EXEC]**.
To cancel deletion of all data, select **[RETURN]**.
- 2 Select **[EXECUTE]**, then touch **[EXEC]**.
- 3 Touch .

Using the (TAPE SET) menu – REC MODE/FRAME REC/INT.REC, etc.

You can select items listed below on the TAPE SET menu. To select these items, see “Changing the menu settings” (p. 43). The default settings are marked with ▷. The indicators in parentheses appear when the

setting is selected. The settings you can adjust vary depending on the power mode of your camcorder. The screen shows the items you can operate at the moment. Unavailable items will be grayed out.

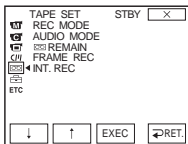

REC MODE

▷SP (<u>SP</u>)	Select to record in the SP (Standard Play) mode on a cassette.
LP (<u>LP</u>)	Select to increase the recording time to 1.5 times the SP mode (Long Play). The use of Sony Excellence/Master mini DV cassette is recommended to get the most out of your camcorder.

- Notes**
- You cannot add sound on the tape recorded in the LP mode.
 - If you record in the LP mode, a mosaic-like noise may appear or sound may be interrupted when you play back the tape on other camcorders or VCRs.
 - When you mix recordings in the SP mode and in the LP mode on one tape, the playback picture may be distorted or the time code may not be written properly between the scenes.

AUDIO MODE

▷12BIT	Select to record in the 12-bit mode (2 stereo sounds).
16BIT (<u>16b</u>)	Select to record in the 16-bit mode (1 stereo sound with high quality).

REMAIN

▷AUTO	Select to display the remaining tape indicator for about 8 seconds: <ul style="list-style-type: none"> • After you select the CAMERA mode with the cassette inserted, and your camcorder calculates the remaining amount of tape. • When you touch  (play/pause).
ON	Select to always display the remaining tape indicator.

FRAME REC

You can record pictures with a stop-motion animated effect by alternately frame recording and then moving the subject a little. Operate your camcorder using the Remote Commander to prevent camera shake.

▷OFF	Select to record in the standard recording mode.
------	--

→ continued

ON 

Select to record pictures using frame recording.

- 1 Select [ON], then touch [EXEC].
- 2 Touch .
- 3 Press REC START/STOP.
A picture (approximately 6 frames) is recorded, and your camcorder enters the standby mode.
- 4 Move the subject and repeat step 3.

Notes

- When you use frame recording continuously, the remaining tape time will not be indicated correctly.
- The last scene will be longer than other scenes.

INT.REC



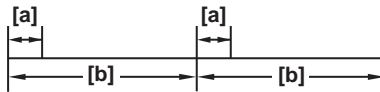

You can record pictures on the tape at a selected interval.

You can achieve excellent recordings of flowers blooming, etc. with this function. Connect your camcorder to the wall outlet using the supplied AC Adaptor during the operation.



a. [REC TIME]

b. [INTERVAL]

- 1 Select [SET], then touch [EXEC].
- 2 Select [INTERVAL], then touch [EXEC].
- 3 Select a desired interval time (30 seconds, 1, 5, 10 minutes), then touch [EXEC].
- 4 Select [REC TIME], then touch [EXEC].
- 5 Select a desired recording time (0.5, 1, 1.5, 2 seconds), then touch [EXEC].
- 6 Touch [ RET.].
- 7 Select [ON], then touch [EXEC].
- 8 Touch .
-  flashes.
- 9 Press REC START/STOP.
Interval recording starts.
 lights up on the screen during Interval recording.
To cancel Interval recording, set to [OFF], then touch [EXEC] in the menu settings.

Note

- There may be a discrepancy in recording time of up to ± 6 frames from the selected time.

Tips

- If you adjust the focus manually, you may be able to record clear pictures even if the light changes (p. 30).
- You can silence the beeps during recording (p. 60).

Using the (SETUP MENU) menu – CLOCK SET/ USB STREAM/LANGUAGE, etc.

You can select items listed below on the SETUP MENU menu. To select items, see “Changing the menu settings” (p. 43).

The default settings are marked with ▷. The settings you can adjust vary depending on the power mode of your camcorder. The screen shows the items you can operate at the moment. Unavailable items will be grayed out.

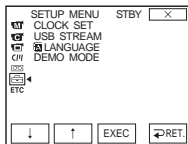

CLOCK SET

You can set the date and time (p. 17).

USB STREAM

You can connect a USB cable (supplied) to your camcorder, and view the picture displayed on the screen of your camcorder on your computer (USB Streaming). For details, refer to the “Computer Applications Guide.”

▷OFF	Select to deactivate the USB Streaming function.
ON	Select to activate the USB Streaming function.

LANGUAGE

You can select or change the language used for the on-screen display (p. 20). You can select from English, Simplified English, Canadian-French, Latin American Spanish, Brazilian-Portuguese, Traditional-Chinese or Korean.

DEMO MODE

When you remove a cassette from your camcorder, and select the CAMERA mode, you can view the demonstration in about 10 minutes.

▷ON	Select to see an overview of the functions available such as when you are using this camcorder for the first time.
OFF	Select when you do not want to use DEMO MODE.

Note

- You can view the demonstration only when the NIGHTSHOT PLUS switch is set to OFF.

Tips

- The demonstration will be suspended in situations such as those described below.
 - When you touch the screen during the demonstration. (The demonstration starts again in about 10 minutes.)
 - When a cassette is inserted.
 - When a mode other than CAMERA is selected.

- If [A.SHUT OFF] is set to [5min] when the camcorder is used on the battery pack, the power will be turned off after approximately 5 minutes (p. 60).

Using the ETC (OTHERS) menu – WORLD TIME, etc.

You can select items listed below on the OTHERS menu. To select these items, see “Changing the menu settings” (p. 43).

The default settings are marked with ▷. The settings you can adjust vary depending on the power mode of your camcorder. The screen shows the items you can operate at the moment. Unavailable items will be grayed out.

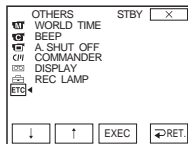

WORLD TIME

You can adjust the time difference when using your camcorder abroad. Set the time difference by touching ↓ / ↑, and the clock will be adjusted in accordance with the time difference. If you set the time difference to 0, the clock returns to the originally set time.

BEEP

▷MELODY	Select to sound a melody when you start/stop recording, operate the touch panel, or when an unusual condition occurs on your camcorder.
NORMAL	Select to sound a beep instead of the melody.
OFF	Select to cancel the melody, the beep sound, the shutter sound or the confirmation beep sound for operation on the touch panel.

A.SHUT OFF

▷5min	Select to activate Auto shut off. When approximately 5 minutes have elapsed while you do not operate your camcorder, the camcorder is automatically turned off to prevent the battery from becoming consumed.
NEVER	Select to deactivate Auto shut off.

Note

- When you connect your camcorder to the wall outlet, [A.SHUT OFF] is automatically set to [NEVER].

COMMANDER

▷ON	Select to use the Remote Commander supplied with your camcorder.
OFF	Select to deactivate the Remote Commander to prevent your camcorder from responding to a command sent by another VCR remote control unit.

Note

- The setting returns to [ON] when you have the power source disconnected from your camcorder for more than 5 minutes.

DISPLAY

▷LCD	Select to show the displays such as the time code on the LCD screen and in the viewfinder.
V-OUT/LCD	Select to show the displays such as the time code on the TV screen, LCD screen, and in the viewfinder.

REC LAMP

▷ON	Select to turn on the camera recording lamp on the front of your camcorder during recording.
OFF	Select this setting in the following recording situations. The camera recording lamp will not light up during recording. <ul style="list-style-type: none">• When you do not want the subject to be nervous about being recorded.• When you are recording close to the subject.• When the subject reflects the recording lamp.

VIDEO EDIT

Select to make programs and dubbing the selected scenes to a tape on a VCR (p. 64).

Connecting to a VCR or TV

You can record the picture from a VCR to a tape inserted into your camcorder (p. 63). You can also create a copy of the picture recorded on your camcorder on other recording device (p. 63). Connect your camcorder to a TV or VCR as shown in the following illustration.

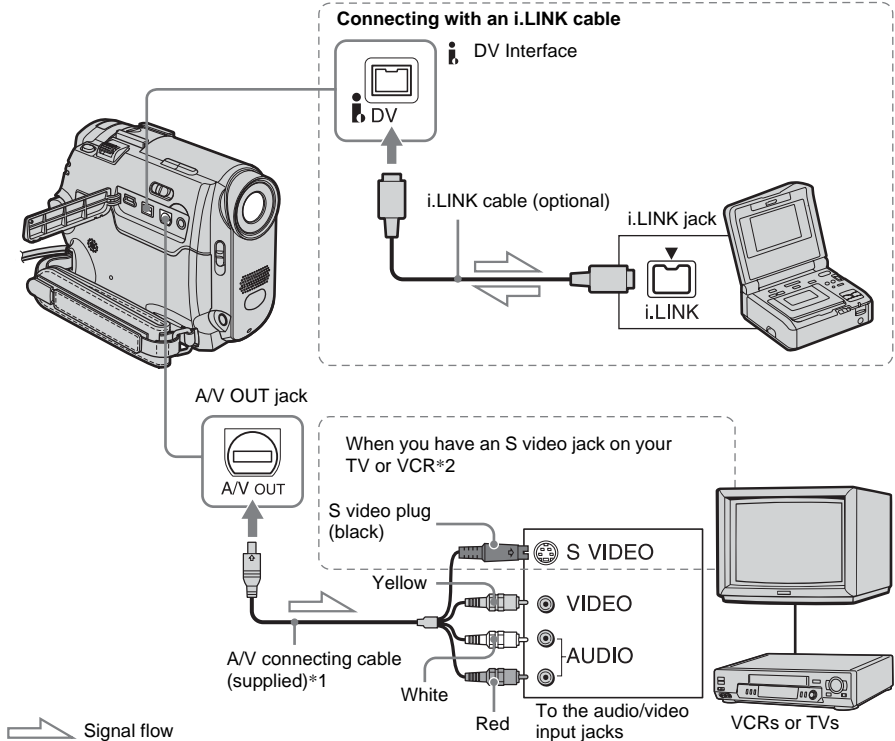

- *1 The supplied A/V connecting cable has a video plug and an S video plug for the video connection.
- *2 This connection produces higher quality DV format pictures. When there is an S video jack on the device to be connected, connect the S video plug to that jack instead of using the yellow video plug. The audio will not be output when you connect with the S video plug alone.

⚡ Notes on the A/V connecting cable

- When you connect your camcorder to the other devices using the A/V connecting cable, make sure the [DISPLAY] setting in the [ETC] (OTHERS) menu is set to [LCD] (the default setting) before connecting (p. 61).
- When you are connecting your camcorder to monaural device, connect the yellow plug of the A/

V connecting cable to the video jack, and the red or the white plug to the audio jack on the VCR or the TV.

To use an i.LINK cable for connection

Use an i.LINK cable (optional) to connect your camcorder to the other device via the DV Interface. The video and sound signals are transmitted digitally, producing high quality pictures. Note that you cannot record the picture and sound separately. For details, see page 85.



Dubbing to another tape

You can copy and edit the picture played back on your camcorder to other recording devices (such as VCRs).

- 1 **Connect your VCR to your camcorder as a recording device (p. 62).**
- 2 **Prepare your VCR for recording.**
 - Insert a cassette for recording.
 - If your VCR has an input selector, set it to the input mode.
- 3 **Prepare your camcorder for playback.**
 - Insert the recorded cassette.
 - Slide the POWER switch repeatedly to select the PLAY/EDIT mode.
- 4 **Start the playback on your camcorder, and record it on the VCR.**

Refer to the operating instructions supplied with your VCR for details.
- 5 **When the dubbing is finished, stop your camcorder and the VCR.**

Notes

- When your camcorder is connected to the VCR via the  DV Interface, you cannot record the title, indicators, information for the Cassette Memory.
- When dubbing using the A/V connecting cable, press DSPL/BATT INFO to hide indicators such as time code (p. 37). Otherwise, they will be recorded on the tape.
- When dubbing using the A/V connecting cable, to record the date/time and camera settings data, have it displayed on the screen (p. 37).
- Pictures edited with Picture effect (IP EFFECT) (p. 45)) cannot be output via the  DV Interface.
- When connected using the i.LINK cable, the recorded picture becomes rough when a picture is paused on your camcorder while recording to a VCR.

Recording pictures from a VCR

You can record and edit pictures from a VCR on a tape inserted in your camcorder via an i.LINK cable.

Insert a cassette for recording in your camcorder.

- 1 **Connect your VCR to your camcorder (p. 62).**
- 2 **Slide the POWER switch repeatedly to select the PLAY/EDIT mode.**
- 3 **Set your camcorder to recording pause mode.**
 - 1 Touch  and select [PAGE3].
 - 2 Touch [REC CTRL].
 - 3 Touch [REC PAUSE].
- 4 **Start playing the cassette on your VCR.**

The picture played on the connected device appears on the LCD screen of your camcorder.
- 5 **Touch [REC START] at the point you want to start recording.**
- 6 **Touch  (stop) to stop recording.**

- 7 **Touch [ RET.], then .**

Tip

- **DVIN** appears when you connect your camcorder and other devices.

Dubbing selected scenes from a tape

- Digital program editing

You can select up to 20 scenes (programs) and record them in the desired order to other recording device such as VCRs.

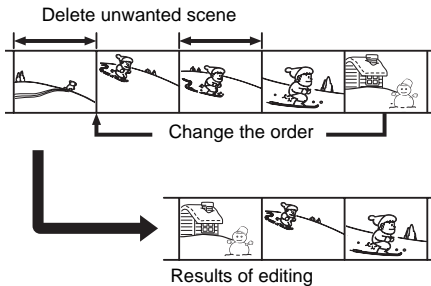

Step 1: Preparing your camcorder and VCR for operation

Follow the steps below when you are performing Digital program editing for the first time to a tape in a VCR. You can skip this setting if you have set up the VCR by the following procedure before.

Notes

- You cannot perform Digital program editing on a VCR that does not support [IR SETUP] codes.
- The operating signal for Digital program editing cannot be transferred via the LANC jack.
- When your camcorder is connected to the VCR via the DV Interface, you cannot record the title, indicators, information for the Cassette Memory.

1 Connect your VCR to the camcorder as a recording device (p. 62).

You can use either the A/V connecting cable or the i.LINK cable to make the connection. The dubbing procedure is easier with the i.LINK connection.

2 Prepare your VCR.

- Insert a cassette for recording.
- Set the input selector to input mode if your VCR has one.

3 Prepare your camcorder (playing device).

- Insert a cassette for editing.
- Slide the POWER switch repeatedly to select the PLAY/EDIT mode.

4 Touch to display [PAGE1].

5 Touch MENU.

6 Select (OTHERS), then select [VIDEO EDIT] with / , then touch [EXEC].

7 Touch [EDIT SET].

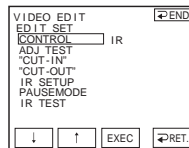

8 Select [CONTROL] with / , then touch [EXEC].

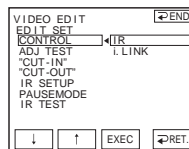

9 Select i.LINK or [IR].

When connecting with an i.LINK cable

Select i.LINK with / , then [EXEC]. Go on to "Step 2: Adjusting the synchronization of the VCR" (p. 66).

When connecting with an A/V connecting cable

Select [IR] with $\boxed{\downarrow}$ / $\boxed{\uparrow}$, then [EXEC]. Follow the procedure described in “To set the [IR SETUP] code” (p. 65).

Go on to “Step 2: Adjusting the synchronization of the VCR” (p. 66).
When recording fails to start, select another [IR SETUP] code and try again.

To set the [IR SETUP] code

When you connect with an A/V connecting cable, you need to check the [IR SETUP] code signal to see if your VCR can be operated by your camcorder (infrared ray emitter).

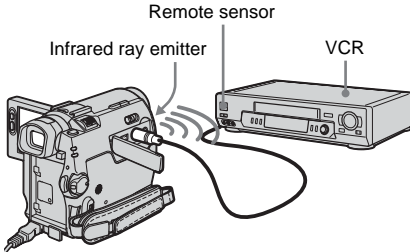

- 1** Select [IR SETUP] with $\boxed{\downarrow}$ / $\boxed{\uparrow}$, then touch [EXEC].
- 2** Select the [IR SETUP] code of your VCR with $\boxed{\downarrow}$ / $\boxed{\uparrow}$, then touch [EXEC].
For the [IR SETUP] code of your VCR, refer to “[IR SETUP] code list” (p. 65). When there is more than 1 code listed for the manufacturer of your VCR, try each code and find the most appropriate one.
- 3** Select [PAUSEMODE] with $\boxed{\downarrow}$ / $\boxed{\uparrow}$, then touch [EXEC].
- 4** Touch $\boxed{\downarrow}$ / $\boxed{\uparrow}$ to select the mode to cancel the recording pause on your VCR, then touch [EXEC].
Refer to the operating instructions supplied with your VCR for details on operation.
- 5** Point the infrared ray emitter of your camcorder towards the remote sensor on your VCR, from about 30 cm (12 in.) away, with no obstructions.
- 6** Insert a cassette into your VCR, and set the VCR to recording pause.
- 7** Select [IR TEST] with $\boxed{\downarrow}$ / $\boxed{\uparrow}$, then touch [EXEC].
- 8** Select [EXECUTE] with $\boxed{\downarrow}$ / $\boxed{\uparrow}$, then touch [EXEC].

The recording starts on your VCR when the setting is correct. [COMPLETE] appears when the [IR SETUP] code test is finished.

[IR SETUP] code list

The following [IR SETUP] codes are recorded on your camcorder by default. (It is set at “3” as the default setting.)

Manufacturing company	[IR SETUP] code
Sony	1, 2, 3, 4, 5, 6
Admiral (M. Wards)	89
Aiwa	47, 54, 80
Akai	49, 51
Audio Dynamic	21, 35
Bell&Howell (M. Wards)	36
Broksonic	21, 70, 82
Canon	77, 78
Citizen	47
Craig	47, 73
Curtis Mathis	8, 77, 80
Daewoo	26, 40, 77
DBX	21, 33, 35
Dimensia	8
Emerson	26, 48, 59, 70, 80, 81, 82
Fisher	36, 37, 44, 45
Funai	80
General Electric	8, 32*, 77, 94*, 101
Goldstar/LG	47
GO VIDEO	71
Hitachi	8, 42, 78
HQ	40
Instant Replay	77, 78
JC Penny	8, 21, 33, 35, 36, 42, 77
JVC	12, 13, 14, 21, 33, 35
Kenwood	21, 33, 35, 47
LXI (Sears)	36, 37, 42, 44, 45, 47, 49, 80
Magnavox	17, 77, 78, 83
Marantz	21, 33, 35

→ continued

Manufacturing company	[IR SETUP] code
Marta	47
Memorex	37, 77
Minolta	8, 42
Mitsubishi/MGA	22, 23, 24, 28, 29
Multitech	23, 32, 80
NEC	21, 33, 35
Olympic	77, 78
Optimus	22
Orion	60
Panasonic	16, 17, 77, 78
Pentax	8, 42
Philco	26, 70, 77, 78
Philips	47, 77, 78, 83
Pioneer	78
Quasar	6, 16, 17, 77, 78
RCA/PROSCAN	7, 8, 16, 40, 41, 42, 77, 78, 78*, 83, 101
Realistic	22, 36, 37, 77, 80, 88
Sansui	21
Singer	73
Samsung	24, 24*, 32, 32*, 41, 94, 94*
Sanyo	26, 36, 37, 47
Scott	22, 23, 24, 28, 32, 37, 40, 41
Sharp	88, 89
Shintom	73
Signature 2000	80, 89
Sylvania	77, 78, 80, 83
Symphonic	80
Tashiro	47
Tatung	21, 33, 35
Teac	21, 33, 35, 80
Technics	77, 78
Toshiba	7, 40, 49
Wards	37, 47, 88, 89, 95
Yamaha	21, 33, 35, 36
Zenith	95

* TV/VCR component

Step 2: Adjusting the synchronization of the VCR

Follow the steps below when you are performing Digital program editing for the first time to a tape in a VCR. You can skip this setting if you have set up your VCR before using the following procedure. You can adjust the synchronization of your camcorder and the VCR to avoid not recording the starting scene.

- 1 Remove the cassette from your camcorder. Prepare a pen and paper to take notes.**
- 2 Set the VCR to recording pause mode.** Skip this step if you have selected i.LINK in step 9 (p. 64).
 - Note**
 - Run the tape for about 10 seconds before pausing. The starting scenes may not get recorded when you start recording from the beginning of the tape.
- 3 Select [ADJ TEST] with \downarrow / \uparrow , then touch [EXEC].**

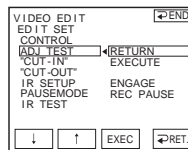

- 4 Select [EXECUTE] with \downarrow / \uparrow , then touch [EXEC].** [EXECUTING] flashes and a picture (about 50 seconds long) with 5 [IN] and [OUT] indicators each for adjusting

synchronization is recorded. [COMPLETE] appears when the recording is finished.

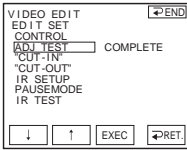

5 Rewind the tape on your VCR, then play back in slow mode.

5 opening numbers for each [IN] and closing numbers for each [OUT] appear.

6 Take a note of the opening number value of each [IN] and the closing number value of each [OUT], then calculate the average number value for each [IN] and [OUT].

7 Select ["CUT-IN"] with [down arrow] / [up arrow], then touch [EXEC].

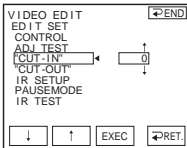

8 Touch [down arrow] / [up arrow] to select the average number value for [IN], then touch [EXEC].

The calculated start position for recording is set.

9 Select ["CUT-OUT"] with [down arrow] / [up arrow], then touch [EXEC].

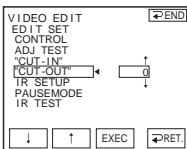

10 Touch [down arrow] / [up arrow] to select the average number value for [OUT], then touch [EXEC].

The calculated stop position for recording is set.

11 Touch [right arrow] END], then touch [X].

Recording the selected scenes as programs

When you are performing Digital program editing for the first time to a tape in a VCR, go through the procedures described in Steps 1 and 2 (p. 64 - p. 66) beforehand.

1 Prepare a cassette.

Insert a tape to be played back into the camcorder, then insert a cassette for recording into your VCR.

2 Touch [FN] to display [PAGE1].

3 Touch MENU.

4 Select [ETC] (OTHERS), then select [VIDEO EDIT] with [down arrow] / [up arrow], then touch [EXEC].

5 Search for the beginning of the first scene that you want to dub on your camcorder, then pause playback.

You can adjust the position with [left arrow] / [right arrow] (frame).

6 Touch [MARK IN].

→ continued

The starting point of the first program is set, and the upper part of the program mark changes to light blue.

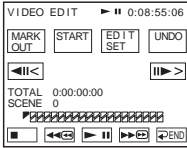

7 Search for the end of the first scene that you want to record on your camcorder, then pause playback.

You can adjust the position with ◀◀/▶▶ (frame).

8 Touch [MARK OUT].

The ending point of the first program is set, and the lower part of the program mark changes to light blue.



9 Repeat steps 5 to 8 and create programs.

10 Set your VCR to recording pause.

Skip this step if your camcorder is connected via an i.LINK cable.

11 Touch [START].



12 Touch [EXEC].

A search for the beginning of the first program starts, then the recording starts.

[SEARCH] appears during the search and [EDITING] appears during editing.

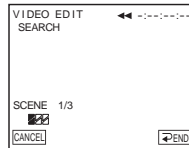

When a program is recorded, the program mark stops flashing and remains lit. When all programs have been recorded, the program editing operation stops automatically.

To cancel recording, touch [CANCEL].

To end Digital program editing

Touch [↶ END].

To save a program without using it to record

Touch [↶ END] in step 9.

The program is stored in memory until the cassette is ejected.

To erase programs

- 1 Follow steps 1 to 4 in “Recording the selected scenes as programs” (p. 67), then touch [UNDO].
- 2 Touch [ERASE 1 MARK] to delete the last set program. Or, touch [ERASE ALL] to delete all the programs.
- 3 Touch [EXEC].
The programs are deleted.
To cancel this operation, touch [CANCEL].

Notes

- You cannot set the starting point or ending point on a blank section of the tape. If there is a blank section, the total time may not appear correctly.
- When you cannot operate the device correctly using an i.LINK cable connection, select [IR] in step 9 on page 64, and set the [IR SETUP] code.

Dubbing sound to a recorded tape

You can record additional audio to the original sound on the tape. You can add sound to a tape already recorded in the 12-bit mode without erasing the original sound.

Preparing for audio recording

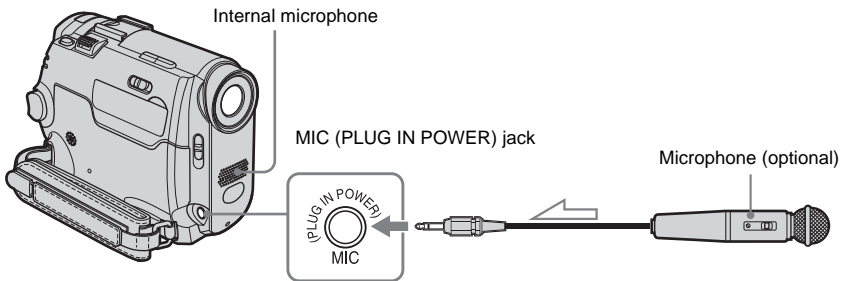

Signal flow

Record audio in one of the following ways.

- Using the internal microphone (no connection required).
- Connecting a microphone (optional) to the MIC jack.

The audio input to be recorded takes precedence over others in the order of MIC jack → internal microphone.

Notes

- You cannot record additional audio:
 - When the tape is recorded in the 16-bit mode.
 - When the tape is recorded in the LP mode.
 - When your camcorder is connected via the i.LINK cable.
 - On blank sections of the tape.
 - When the write-protect tab of the cassette is set to SAVE.
- When you are using the internal microphone to record additional sound, the picture will not be output from the A/V OUT jack. Check the picture on the LCD screen or the viewfinder.
- When you use an external microphone (optional) to record additional audio, you can check the picture

and the sound by connecting your camcorder to a TV using the A/V connecting cable. However, the sound you have recorded afterwards is not output from the speaker. Check the sound by using a TV.

Recording sound

- 1 **Insert a recorded tape into your camcorder.**
- 2 **Slide the POWER switch repeatedly to select the PLAY/EDIT mode.**
- 3 **Touch  (play) to play back the tape.**

→ continued

4 Touch (pause) again at the point where you want to start recording the sound.

The playback pauses.

5 Touch and select [PAGE3].

6 Touch [A DUB CTRL].

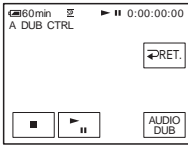

7 Touch [AUDIO DUB].

A green mark appears on the LCD screen.

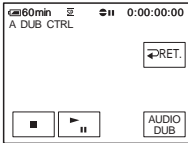

8 Touch (play) and start playing back the audio you want to record at the same time.

A red mark remains on the LCD screen while recording sound.

The new sound is recorded in stereo 2 ([ST2]) during the playback of the tape.

9 Touch (stop) when you want to stop recording.

To dub on other scenes, repeat steps 3 and 4 to select scenes, then touch [AUDIO DUB].

10 Touch [RET.], then [X] .

To set the end point for audio dubbing

During playback, press ZERO SET MEMORY on the Remote Commander at the scene at which you want to stop audio dubbing. Then,

perform steps 4 to 8. The recording stops automatically at the selected scene.

Note

- You can only record additional audio over a tape recorded on your camcorder. The sound may deteriorate when you dub audio on a tape recorded on other camcorders (including other DCR-HC20 camcorders).

Checking and adjusting the recorded sound

1 Play back the tape on which you have recorded audio in “Recording sound” (p. 69).

2 Touch to display [PAGE1].

3 Touch MENU.

4 Select (VCR SET), then select [AUDIO MIX] with / , then touch [EXEC].

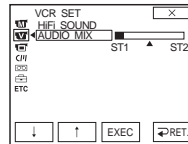

5 Touch / to adjust the balance between the original sound ([ST1]) and the sound added afterwards ([ST2]). Then, touch [EXEC].

The original sound ([ST1]) is output in the default setting.

The adjusted audio balance returns to the default setting in about 5 minutes after the battery pack or other power sources have been disconnected.

Creating DVDs or VCDs

When your camcorder is connected to a Sony VAIO series personal computer, you can easily burn the picture recorded on the tape to a DVD (Direct Access to “Click to DVD”). And, when your camcorder is connected to a personal computer, you can easily burn the picture recorded on the tape to a CD-R (Direct Access to Video CD Burn).

1 Touch  and select [PAGE2].

2 Touch [BURN DVD] when creating a DVD, or touch [BURN VCD] when creating a VCD.

For details, refer to the “Computer Applications Guide.”

Troubleshooting

If you run into any problem using your camcorder, use the following table to troubleshoot the problem. If the problem

persists, remove the power source and contact your Sony dealer.

If “C:□□:□□” is displayed on the LCD screen or the viewfinder, the self-diagnosis display function is activated. See page 78 for details.

Overall operations



Symptom	Cause and/or Corrective Actions
The power does not turn on.	<ul style="list-style-type: none"> • The battery pack is discharged, running low, or not attached to the camcorder. <ul style="list-style-type: none"> → Attach a charged battery pack to the camcorder. (p. 12) → Use the AC Adaptor to connect to the wall outlet. (p. 14)
The camcorder does not operate even when the power is set to on.	<ul style="list-style-type: none"> → Disconnect the AC Adaptor from a wall outlet or remove the battery pack, then reconnect it after about 1 minute. If the functions still do not work, press the RESET button using a sharp-pointed object. (If you press the RESET button, all settings including the clock setting are reset.)
The supplied Remote Commander does not function.	<ul style="list-style-type: none"> → Set [COMMANDER] on the ETC (OTHERS) menu to [ON]. (p. 60) → Insert a battery into the battery holder with the + – polarities correctly matching the + – marks. If this still does not solve the problem, insert a new battery since the battery is dead. (p. 95) → Remove any obstructions between the Remote Commander and the remote sensor.
The camcorder gets warm.	<ul style="list-style-type: none"> • This is because the power has been turned on for a long time. This is not a malfunction.

Battery/Power sources

Symptom	Cause and/or Corrective Actions
The CHG (charge) lamp does not light while the battery pack is being charged.	<ul style="list-style-type: none"> → Attach the battery pack to the camcorder correctly. If the lamp still does not light up, then it indicates that no power is supplied from the wall outlet. • The battery charge is completed. (p. 12)
The CHG (charge) lamp flashes while the battery pack is being charged.	<ul style="list-style-type: none"> → Attach the battery pack to the camcorder correctly. If the problem persists, disconnect the AC Adaptor from the wall outlet and contact your Sony dealer. The battery pack may be damaged. (p. 12)
The battery pack is quickly discharged.	<ul style="list-style-type: none"> • The temperature of the environment is too low, or the battery pack has not been charged enough. This is not a malfunction. <ul style="list-style-type: none"> → Fully charge the battery again. If the problem persists, replace the battery pack with a new one. It may be damaged. (p. 12, 83)

Symptom	Cause and/or Corrective Actions
The remaining battery time indicator does not indicate the correct time.	<ul style="list-style-type: none"> The temperature of the environment is too high or too low, or the battery pack has not been charged enough. This is not a malfunction. →Fully charge the battery again. If the problem persists, replace the battery pack with a new one. It may be damaged. (p. 12, 84)
The power turns off frequently although the remaining battery indicator indicates that the battery pack has enough power to operate.	<ul style="list-style-type: none"> A problem has occurred in the remaining battery time indicator, or the battery pack has not been charged enough. →Fully charge the battery again to correct the indication. (p. 12)
The power abruptly turns off.	<ul style="list-style-type: none"> [A.SHUT OFF] in the  (OTHERS) menu is set to [5min]. (p. 60) →When approximately 5 minutes have elapsed while you do not operate your camcorder, the camcorder is automatically turned off. Slide the POWER switch down to turn the power on again. (p. 15) Or use the AC Adaptor.
A problem occurs when the camcorder is connected to the AC Adaptor.	→Turn off the power, and disconnect the AC Adaptor from the wall outlet. Then, connect it again.

Cassette tapes

Symptom	Cause and/or Corrective Actions
Cassette cannot be ejected from the compartment.	<ul style="list-style-type: none"> →Make sure the power source (battery pack or AC Adaptor) is connected correctly. (p. 12) →Remove the battery pack from the camcorder, then attach it again. (p. 12) →Attach a charged battery pack to the camcorder. (p. 12)
Cassette is not ejected even when the cassette lid is open.	<ul style="list-style-type: none"> Moisture condensation is starting in your camcorder. (p. 86)
The Cassette Memory indicator does not appear while using a cassette with Cassette Memory.	→Clean the gold-plated connector of the cassette. (p. 83)
The remaining tape indicator is not displayed.	→Set [ REMAIN] to [ON] on the  (TAPE SET) menu to always display the remaining tape indicator. (p. 55)
A cassette label is not recorded.	<ul style="list-style-type: none"> →Use a cassette with Cassette Memory. (p. 82) →Erase unnecessary titles when the Cassette Memory is full. (p. 53) →Set the write-protect tab to REC. (p. 82)



LCD screen/viewfinder



Symptom	Cause and/or Corrective Actions
An unknown language appears on the screen.	→See page 20.

→continued



Symptom	Cause and/or Corrective Actions
An unknown picture appears on the screen.	<ul style="list-style-type: none"> The camcorder is in [DEMO MODE]. ([DEMO MODE] is automatically displayed when you leave the camcorder for 10 minutes after selecting CAMERA without inserting a cassette.) <ul style="list-style-type: none"> →Touch on the LCD screen or insert a cassette to cancel [DEMO MODE]. You can also set [DEMO MODE] to [OFF] on the  (SETUP MENU) menu. (p. 58)
An unknown indicator appears on the screen.	→Refer to the indicator list. (p. 97)
The buttons do not appear on the touch panel.	<ul style="list-style-type: none"> →Touch the LCD panel lightly. →Press DSPL/BATT INFO (or DISPLAY on the Remote Commander). (p. 37)
The buttons on the touch panel do not work correctly or do not work at all.	→Adjust the screen ([CALIBRATION]). (p. 87)
The picture in the viewfinder is not clear.	<ul style="list-style-type: none"> →Extend the viewfinder. (p. 16) →Use the viewfinder lens adjustment lever to adjust the lens. (p. 16)
The picture in the viewfinder has disappeared.	→Close the LCD panel. The picture is not displayed in the viewfinder when the LCD panel is open. (p. 16)
The picture remains on the LCD screen.	<ul style="list-style-type: none"> This occurs when your camcorder is turned off forcibly by removing the battery pack, disconnecting the DC plug from your camcorder or the like while turning on the power. This is not a malfunction.

Recording

Symptom	Cause and/or Corrective Actions
The tape does not start when you press REC START/STOP.	<ul style="list-style-type: none"> →Slide the POWER switch to select the CAMERA mode. (p. 15) →The tape has reached the end. Rewind it, or insert a new cassette. →Set the write-protect tab to REC or insert a new cassette. (p. 82) →The tape is stuck to the drum due to moisture condensation. Remove the cassette and leave your camcorder for at least 1 hour, then re-insert the cassette. (p. 86)
The power abruptly turns off.	<ul style="list-style-type: none"> [A.SHUT OFF] in the  (OTHERS) menu is set to [5min]. (p. 60) <ul style="list-style-type: none"> →When approximately 5 minutes have elapsed while you do not operate your camcorder, the camcorder is automatically turned off. Slide the POWER switch down to turn the power on again. (p. 15) Or use the AC Adaptor. →Charge the battery pack. (p. 12)
The SteadyShot function does not function.	→Set STEADYSHOT to [ON] in the  (CAMERA SET) menu. (p. 48)
Auto focus does not function.	<ul style="list-style-type: none"> →Set [FOCUS] to [ AUTO]. (p. 30) →The recording conditions are not suitable for auto focus. Adjust the focus manually. (p. 30)
A vertical band appears when recording candlelight or electric light in the dark.	<ul style="list-style-type: none"> This occurs when the contrast between the subject and the background is too high. This is not a malfunction.

Symptom	Cause and/or Corrective Actions
A vertical band appears when recording a bright subject.	<ul style="list-style-type: none"> This phenomenon is called the smear effect. This is not a malfunction.
The color of the picture is not correctly displayed.	→Deactivate the NightShot plus function. (p. 29)
Picture appears too bright on the screen, and the subject does not appear on the screen.	→Deactivate the NightShot plus function in bright places. (p. 29) →Cancel the back light function. (p. 26)
The screen is too dark for the image to be seen.	→Set LCD BACKLIGHT to turn on the backlight for the LCD panel. (p. 16)
The shutter sound is not heard.	→Set [BEEP] to [MELODY] or [NORMAL] on the  (OTHERS) menu. (p. 60)
Black bands appear when you record a TV screen or computer screen.	→Set STEADYSHOT to [OFF] on the  (CAMERA SET) menu. (p. 48)
The external flash (optional) does not work.	<ul style="list-style-type: none"> The power of the flash is not turned on, or the flash is not attached correctly. 2 or more flashes are attached. Only 1 external flash can be attached.
Flickering or changes in color occurs.	<ul style="list-style-type: none"> This occurs when recording pictures under a fluorescent lamp, sodium lamp, or mercury lamp in the [PORTRAIT] or [SPORTS] mode. →Set the [PROGRAM AE] to [AUTO] in the  (MANUAL SET) menu. (p. 44)
The END SEARCH function does not work.	<ul style="list-style-type: none"> The cassette was ejected after recording when using a cassette without Cassette Memory. (p. 82) The cassette is new and has nothing recorded.
The END SEARCH function does not work correctly.	<ul style="list-style-type: none"> There is a blank section in the beginning or middle of the tape. This is not a malfunction.

Playback

Symptom	Cause and/or Corrective Actions
Cannot play back.	→If the tape has reached the end, rewind the tape. (p. 34)
Horizontal lines appear on the picture. The displayed pictures are not clear or do not appear.	→Clean the head using the cleaning cassette (optional). (p. 87)
No sound or only a low sound is heard.	→Set [HiFi SOUND] to [STEREO] in the  (VCR SET) menu. (p. 50) →Turn up the volume. (p. 34) →On the  (VCR SET) menu, adjust [AUDIO MIX] from the [ST2] (additional sound) side until the sound is heard appropriately. (p. 50) →When you are using an S video plug, make sure the red and white plugs of the A/V connecting cable are connected as well. (p. 39)
The sound breaks off.	→Clean the head using the cleaning cassette (optional). (p. 87)

→continued

Symptom	Cause and/or Corrective Actions
Cannot perform Date search with the recording date displayed on the screen.	<ul style="list-style-type: none"> → Use a cassette with Cassette Memory. (p. 82) → Set [CM SEARCH] to [ON] in the [CM] (CM SET) menu. (p. 54) • There is a blank section in the beginning or middle of the tape. This is not a malfunction.
“---” is displayed on the screen.	<ul style="list-style-type: none"> • The tape you are playing was recorded without setting the date and time. • A blank section on the tape is being played. • The data code on a tape with a scratch or noise cannot be read.
The END SEARCH function does not work.	<ul style="list-style-type: none"> • The cassette was ejected after recording when using a cassette without Cassette Memory. (p. 82) • The cassette is new and has nothing recorded.
The END SEARCH function does not work correctly.	<ul style="list-style-type: none"> • There is a blank section in the beginning or middle of the tape. This is not a malfunction.
Noises appear and pal is displayed on the screen.	<ul style="list-style-type: none"> • The tape was recorded in a TV color system other than that of your camcorder. This is not a malfunction. (p. 81)

Dubbing/Editing

Symptom	Cause and/or Corrective Actions
Cannot dub correctly using the A/V connecting cable.	<ul style="list-style-type: none"> → Make sure your camcorder is connected correctly to the input jack of the other device via the A/V connecting cable. → Set [DISPLAY] to [LCD] in the [ETC] (OTHERS) menu. (p. 61)
Pictures from connected devices are not displayed correctly.	<ul style="list-style-type: none"> • The input signal is not NTSC. (p. 63)
New sound added to a recorded tape is not heard.	<ul style="list-style-type: none"> → In the [V] (VCR SET) menu, adjust [AUDIO MIX] from the [ST1] (original sound) side until the sound is heard appropriately. (p. 50)
A title is not recorded/A cassette label is not recorded.	<ul style="list-style-type: none"> → Use a cassette with Cassette Memory. (p. 82) → Erase unnecessary titles when the Cassette Memory is full. (p. 53) → Set the write-protect tab to REC. (p. 82) • A title cannot be added to a blank section of the tape.
The title is not displayed.	<ul style="list-style-type: none"> → Set [TITLE DSPL] to [ON] in the [CM] (CM SET) menu. (p. 53) • During Easy Handycam operation, the title is not displayed.
The title cannot be deleted.	<ul style="list-style-type: none"> → Set the write-protect tab to REC. (p. 82)
Title search does not work.	<ul style="list-style-type: none"> → Enter a title if there is no title on the tape. (p. 52) → Use a cassette with Cassette Memory. (p. 82) → Set [CM SEARCH] to [ON] in the [CM] (CM SET) menu. (p. 54) • There is a blank section in the beginning or middle of the tape. This is not a malfunction.

Symptom	Cause and/or Corrective Actions
<p>Digital program editing does not function.</p>	<ul style="list-style-type: none"> →Set the input selector on the VCR correctly, then check the connection between your camcorder and the VCR. (p. 62) →When your camcorder is connected to a DV device that is not a Sony product via an i.LINK cable, select [IR] in step 9 of “Step 1: Preparing your camcorder and VCR for operation” (p. 64). →Adjust the synchronization of the VCR. (p. 66) →Enter a correct [IR SETUP] code. (p. 65) →Select the mode used to cancel recording pause again. (p. 65) →Set your camcorder and the VCR more than 30 cm (12 in.) apart. (p. 65) • The program may not be set to a blank section on the tape.
<p>The VCR is not responding properly during Digital program editing when it is connected via an i.LINK cable.</p>	<ul style="list-style-type: none"> • While connecting via an i.LINK cable, select [IR] in step 9 of “Step 1: Preparing your camcorder and VCR for operation” (p. 64).

Warning indicators and messages

Self-diagnosis display/Warning indicators

If indicators appear on the screen or in the viewfinder, check the following. See the page in parentheses for details.







Indication	Cause and/or Corrective Actions
C:□□:□□/E:□□:□□ (Self-diagnosis display)	<p>Some symptoms can be fixed by yourself. If the problem persists even after you tried a couple of times, contact your Sony dealer or local authorized Sony service facility.</p> <p>C:04:□□</p> <p>→ A battery pack that is not an "InfoLITHIUM" battery pack is being used. Use an "InfoLITHIUM" battery pack. (p. 83)</p> <p>C:21:□□</p> <p>→ Moisture condensation has occurred. Remove the cassette and leave your camcorder for at least 1 hour, then re-insert the cassette. (p. 86)</p> <p>C:22:□□</p> <p>→ Clean the head using a cleaning cassette (optional). (p. 87)</p> <p>C:31□□ / C:32□□</p> <p>→ Symptoms that are not described above have occurred. Remove and insert the cassette, then operate your camcorder again. Do not perform this procedure if moisture starts to condense. (p. 86)</p> <p>→ Remove the power source. Reconnect it again and operate your camcorder again.</p> <p>→ Change the tape.</p> <p>→ Press the RESET button (p. 92), then operate your camcorder again.</p> <p>E:61:□□ / E:62:□□</p> <p>→ Contact your Sony dealer or local authorized Sony service facility. Inform them of the 5-digit code, which starts from "E."</p>
⚡ (Battery level warning)	<ul style="list-style-type: none"> The battery pack is nearly used up. Depending on the operating, environmental, or battery conditions, ⚡ may flash, even if there are approximately 5 to 10 minutes remaining.
☒ (Moisture condensation warning)*	<p>→ Eject the cassette, slide the POWER switch up to OFF (CHG), and leave it for about 1 hour with the cassette lid open (p. 86).</p>
⏸ (Warning indicator pertaining to the tape)	<p>Slow flashing:</p> <ul style="list-style-type: none"> There is less than 5 minutes remaining on the tape. No cassette is inserted.* The write-protect tab on the cassette is set to lock (p. 82).* <p>Fast flashing:</p> <ul style="list-style-type: none"> The tape has run out.*
⏏ (Eject cassette warning)*	<p>Slow flashing:</p> <ul style="list-style-type: none"> The write-protect tab on the cassette is set to lock (p. 82). <p>Fast flashing:</p> <ul style="list-style-type: none"> Moisture condensation has occurred (p. 86). The self-diagnosis display code is displayed (p. 78).

Indication	Cause and/or Corrective Actions
<p>⚡ (Warning indicator pertaining to the external flash)</p>	<p>Slow flashing:</p> <ul style="list-style-type: none"> • During charging <p>Fast flashing:</p> <ul style="list-style-type: none"> • The self-diagnosis display code is displayed (p. 78).* • There is something wrong with the external flash (optional).

* You hear a melody or beep sound when the warning indicators appear on the screen.

Warning messages

If messages appear on the screen, check the following. See the page in parentheses for details.

Subjects	Indications	Corrective Actions/References
Battery	Use the "InfoLITHIUM" battery pack.	→See page 83.
	Battery level is low.	→Charge the battery (p. 12).
	Old battery. Use a new one.	→See page 83.
	▲ Re-attach the power source.	–
Moisture condensation	 ▲ Moisture condensation. Eject the cassette	→See page 86.
	 Moisture condensation. Turn off for 1H.	→See page 86.
Cassette/tape	 Insert a cassette.	→See page 19.
	▲ Reinsert the cassette.	→The cassette might be damaged, etc.
	 ▲ The tape is locked - check the tab.	→See page 82.
	 The tape has reached the end.	–
	Use a cassette with Cassette Memory.	→See page 82.
	Charging... Cannot record still images.	• You tried to record an image while charging the flash. Wait until the flash charge indicator remains lit.
Others	Cannot record due to copyright protection.	–
	Cannot add audio. Disconnect the i.LINK cable.	→See page 69.
	Not recorded in SP mode. Cannot add audio.	→See page 69.
	Not recorded in 12-bit audio. Cannot add audio.	→See page 69.
	Cannot add audio on the blank portion of a tape.	→See page 69.
	Cassette Memory is full.	→See page 54.
	 Dirty video head. Use a cleaning cassette.	→See page 87.
	Cannot start Easy Handycam	→See page 25, 36.
	Cannot cancel Easy Handycam	→See page 25, 36.
	Cannot start Easy Handycam with USB connected	–
	Invalid button with Easy Handycam operation	→See page 25, 36.
	USB invalid during Easy Handycam	→Touch [OK].
	HDV recorded tape. Cannot playback.	→Your camcorder cannot play back this format. Play back the tape with equipment that recorded it.
	HDV recorded tape. Cannot add audio.	→Your camcorder cannot play back this format. Add audio with equipment that recorded it.
	Cover is not open.	→Open the lens cover.

Using your camcorder abroad

Power supply

You can use your camcorder in any countries/regions using the AC Adaptor supplied with your camcorder within AC 100 V to 240 V, 50/60 Hz.

Use a commercially available AC plug adaptor [a], if necessary, depending on the design of the wall outlet [b].



On TV color systems

Your camcorder is an NTSC system-based camcorder. If you want to view the playback picture on a TV, it must be an NTSC system-based TV (see the following list) with the AUDIO/VIDEO input jack.

System	Used in
NTSC	Bahama Islands, Bolivia, Canada, Central America, Chile, Colombia, Ecuador, Guyana, Jamaica, Japan, Korea, Mexico, Peru, Surinam, Taiwan, the Philippines, the U.S.A., Venezuela, etc.
PAL	Australia, Austria, Belgium, China, Czech Republic, Denmark, Finland, Germany, Holland, Hong Kong, Hungary, Italy, Kuwait, Malaysia, New Zealand, Norway, Poland, Portugal, Singapore, Slovak Republic, Spain, Sweden, Switzerland, Thailand, United Kingdom, etc.
PAL - M	Brazil
PAL - N	Argentina, Paraguay, Uruguay
SECAM	Bulgaria, France, Guiana, Iran, Iraq, Monaco, Russia, Ukraine, etc.

Simple setting of clock by time difference

You can easily set the clock to the local time by setting a time difference when using your camcorder abroad. Select [WORLD TIME] in the [ETC] (OTHERS) menu, then set the time difference (p. 60).

Usable cassette tapes

You can use the mini DV format cassette only. Use a cassette with the ^{Mini}DV mark.

Mini DV ^{Digital Video Cassette} is a trademark.

Cassette Memory

There are 2 types of mini DV cassettes: those with Cassette Memory and those without Cassette Memory. Cassettes with Cassette Memory have the **CM** (Cassette Memory) mark. A cassette with Cassette Memory is recommended for use on your camcorder.

CM Cassette Memory is a trademark.

IC memory is mounted on this type of cassette. Your camcorder can read and write data such as dates of recording or titles from/to this memory. The functions using the Cassette Memory require successive signals recorded on the tape. If the tape has a blank section at the beginning or between recorded sections, titles may not be displayed properly or the search functions may not work properly.

To prevent a blank section from being made on the tape

Touch [END SCH] to go to the end of the recorded section before you begin the next recording in the following cases:

- You have ejected the cassette during recording.
- You have played back the tape.
- You have used the EDIT SEARCH function.

If there is a blank section or discontinuous signals on your tape, re-record from the beginning to the end of the tape as described above.

Note

- The Cassette Memory may not function correctly when you record using a digital video camera recorder that does not support Cassette Memory, on a tape already recorded on using a Cassette Memory-compatible digital video camera recorder.

Tip

- The memory capacity of the cassette marked with **CM 4K** is 4k bits. Your camcorder can accommodate cassettes having a memory capacity of up to 16k bits.

Copyright signal

When you play back

If the cassette you play back on your camcorder contains copyright signals, you cannot copy it to a tape in another video camera connected to your camcorder.

When you record

You cannot record software on your camcorder that contains copyright control signals for copyright protection of software.

[Cannot record due to copyright protection.] appears on the LCD screen, or on the TV screen if you try to record such software.

Your camcorder does not record copyright control signals on the tape when it records.

Notes on use

To prevent accidental erasure

Slide the write-protect tab on the cassette to set to SAVE.

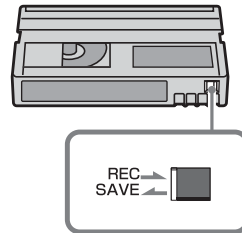

REC: The cassette can be recorded.

SAVE: The cassette cannot be recorded (write-protected).

When labeling the cassette

Be sure to place the label only on the locations as shown in the following illustration so as not to cause malfunction of your camcorder.

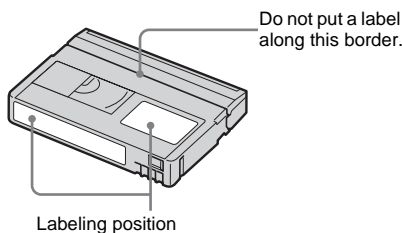

After using the cassette

Rewind the tape to the beginning to avoid distortion of the picture or the sound. The cassette should then be put in its case, and stored in an upright position.

When the Cassette Memory function does not work

Re-insert the cassette. Cassette Memory may not work when the gold-plated connector is dirty or dusty.

When cleaning the gold-plated connector

Generally, clean the gold-plated connector on a cassette with a cotton-wool swab after every 10 times it has been ejected.

If the gold-plated connector on the cassette is dirty or dusty, the remaining tape indicator may not be indicated correctly, and you may not be able to operate functions using Cassette Memory.

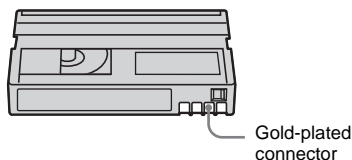

About the “InfoLITHIUM” battery pack

This unit is compatible with the “InfoLITHIUM” battery pack (P series). Your camcorder operates only with the “InfoLITHIUM” battery pack. “InfoLITHIUM” P series battery packs have the  mark.

What is the “InfoLITHIUM” battery pack?

The “InfoLITHIUM” battery pack is a lithium-ion battery pack that has functions for communicating information related to operating conditions between your camcorder and an optional AC Adaptor/charger. The “InfoLITHIUM” battery pack calculates the power consumption according to the operating conditions of your camcorder, and displays the remaining battery time in minutes. With an AC Adaptor/charger (optional), the remaining battery time and charging time appear.

To charge the battery pack

- Be sure to charge the battery pack before you start using your camcorder.
- We recommend charging the battery pack in an ambient temperature of between 10°C to 30°C (50°F to 86°F) until the CHG (charge) lamp turns off. If you charge the battery pack outside of this temperature range, you may not be able to charge it efficiently.
- After charging is complete, either disconnect the cable from the DC IN jack on your camcorder or remove the battery pack.

To use the battery pack effectively

- Battery pack performance decreases when the surrounding temperature is 10°C (50°F) or below, and the length of time you can use the battery pack becomes shorter. In that case, do one of the followings to use the battery pack for a longer time.
 - Put the battery pack in a pocket to warm it up, and insert it in your camcorder right before you start taking shots.
 - Use a large capacity battery pack: NP-FP70/FP90 (optional).
- Frequent use of the LCD screen or a frequent playback, fast forward or rewind operation wears out the battery pack faster. We recommend using a large capacity battery pack: NP-FP70/FP90 (optional).
- Be sure to set the POWER switch to OFF (CHG) when not recording or playing back on your camcorder. The battery pack is also consumed when your camcorder is in recording standby or playback pause.
- Have spare battery packs ready for 2 or 3 times the expected recording time, and make trial recordings before making the actual recording.
- Do not expose the battery pack to water. The battery pack is not water resistant.

About remaining battery time indicator

- When the power goes off even though the remaining battery time indicator indicates that the battery pack has enough power to operate, charge the battery pack fully again. The indication on the remaining battery time will be indicated correctly. Note, however, that the battery indication will not be restored if it is used in high temperatures for a long time, or if left in a fully charged state, or when the battery pack is frequently used.

Use the remaining battery time indication as a guide to the approximate shooting time.
- The  mark that indicates low battery flashes even if there are still 5 to 10 minutes of battery time remaining, depending on the operating conditions or ambient temperature and environment.

About storage of the battery pack

- If the battery pack is not used for a long time, fully charge the battery pack and use it on your camcorder once a year to maintain the proper function.

To store the battery pack, remove it from your camcorder and put it in a dry, cool place.
- To completely use up the battery pack on your camcorder, set [A.SHUT OFF] to [NEVER] on the  (OTHERS) menu (p. 60) and leave your camcorder in tape recording standby until the power goes off without a cassette inserted.

About battery life

- The battery life is limited. Battery capacity drops little by little as you use it more and more, and as time passes. When the available battery time is shortened considerably, a probable cause is that the battery pack has reached the end of its life. Please buy a new battery pack.
- The battery life varies depending on how it is stored and the operating conditions and environment for each battery pack.

“InfoLITHIUM” is a trademark of Sony Corporation.

About i.LINK

The DV Interface on this unit is an i.LINK-compliant DV Interface. This section describes the i.LINK standard and its features.

What is i.LINK?

i.LINK is a digital serial interface for transferring digital video, digital audio, and other data to other i.LINK-compatible device. You can also control other device using the i.LINK.

i.LINK-compatible device can be connected using an i.LINK cable. Possible applications are operations and data transactions with various digital AV devices.

When 2 or more i.LINK-compatible devices are connected to this unit in a daisy chain, operations and data transactions are possible with not only the device that this unit is connected to but also with other devices via the directly connected device.

Note, however, that the method of operation sometimes varies according to the characteristics and specifications of the device to be connected. Also, operations and data transactions may not be possible on some connected devices.

Note

- Normally, only one device can be connected to this unit with the i.LINK cable. When connecting this unit to i.LINK-compatible device having 2 or more DV Interfaces, refer to the operating instructions of the device to be connected.

Tips

- i.LINK is a more familiar term for the IEEE 1394 data transport bus proposed by Sony, and is a trademark approved by many corporations.
- IEEE 1394 is an international standard standardized by the Institute of Electrical and Electronics Engineers.

About i.LINK Baud rate

i.LINK's maximum baud rate varies according to the device. There are 3 types.

- S100 (approx. 100Mbps*)
- S200 (approx. 200Mbps)
- S400 (approx. 400Mbps)

The baud rate is listed under "Specifications" in the operating instructions of each piece of

device. It is also indicated near the i.LINK interface on some devices.

The maximum baud rate for device that does not have any indication (such as this unit) is "S100."

The baud rate may differ from the indicated value when the unit is connected to device with a different maximum baud rate.

* What is Mbps?

Mbps stands for "megabits per second," or the amount of data that can be sent or received in 1 second. For example, a baud rate of 100 Mbps means that 100 megabits of data can be sent in 1 second.

To use i.LINK functions on this unit

For details on how to dub when this unit is connected to other video device having a DV Interface, see page 62, 63.

This unit can also be connected to other i.LINK (DV Interface) compatible device made by Sony (e.g. a VAIO series personal computer) as well as to video device.

Before connecting this unit to your computer, make sure that application software supported by this unit is already installed on your computer.

Some i.LINK compatible video devices such as Digital Televisions, DVD recorders/players, and MICROMV recorders/players are not compatible with DV device. Before connecting to other device, be sure to confirm whether the device is compatible with DV device or not. For details on precautions and compatible application software, refer also to the operating instructions for the device to be connected.

About the required i.LINK cable

Use the Sony i.LINK 4-pin-to-4-pin cable (during DV dubbing).

i.LINK and  are trademarks of Sony Corporation.

Maintenance and precautions

On use and care





- Do not use or store the camcorder and accessories in the following locations.
 - Anywhere extremely hot or cold. Never leave them exposed to temperatures above 60°C (140°F), such as under direct sunlight, near heaters or in a car parked in the sun. They may malfunction or become deformed.
 - Near strong magnetic fields or mechanical vibration. The camcorder may malfunction.
 - Near strong radio waves or radiation. The camcorder may not be able to record properly.
 - Near AM receivers and video equipment. Noise may occur.
 - Sandy beach or anywhere dusty. If sand or dust gets in your camcorder, it may malfunction. Sometimes this malfunction cannot be repaired.
 - Near windows or outdoors, where the LCD screen, the viewfinder, or the lens may be exposed to direct sunlight. This damages the inside of the viewfinder or the LCD screen.
 - Anywhere very humid.
- Operate your camcorder on DC 7.2 V (battery pack) or DC 8.4 V (AC Adaptor).
- For DC or AC operation, use the accessories recommended in these operating instructions.
- Do not let your camcorder get wet, for example, from rain or sea water. If your camcorder gets wet, it may malfunction. Sometimes this malfunction cannot be repaired.
- If any solid object or liquid get inside the casing, unplug your camcorder and have it checked by a Sony dealer before operating it any further.
- Avoid rough handling, disassembling, modifying, or mechanical shock. Be particularly careful of the lens.
- Keep the POWER switch setting to OFF (CHG) when you are not using your camcorder.

- Do not wrap your camcorder with a towel, for example, and operate it. Doing so might cause heat to build up inside.
- When disconnecting the power cord, pull by the plug and not the cord.
- Do not damage the power cord such as by placing anything heavy on it.
- Keep metal contacts clean.
- Keep the Remote Commander and button-type battery out of children's reach. If the battery is accidentally swallowed, consult a doctor immediately.
- If the battery electrolytic liquid has leaked,
 - consult your local authorized Sony service facility.
 - wash off any liquid that may have contacted your skin.
 - if any liquid gets in your eyes, wash with plenty of water and consult a doctor.



When not using your camcorder for a long time

Occasionally turn it on and let it run such as by playing back tapes for about 3 minutes. Otherwise, unplug it from the wall outlet.

Moisture condensation

If your camcorder is brought directly from a cold place to a warm place, moisture may condense inside your camcorder, on the surface of the tape, or on the lens. In this state, the tape may stick to the head drum and be damaged or your camcorder may not operate correctly. If there is moisture inside your camcorder, [  Moisture condensation. Eject the cassette] or [  Moisture condensation. Turn off for 1H.] appears. The indicator will not appear when the moisture condenses on the lens.

If moisture condensation has occurred

None of the functions except cassette ejection will work. Eject the cassette, turn off your camcorder, and leave it for about 1 hour with the cassette lid open. Your camcorder can be used again if  or  does not appear when the power is turned on again.

If moisture starts to condense, your camcorder sometimes cannot detect condensation. If this happens, the cassette is sometimes not ejected for 10 seconds after the cassette lid is opened. This is not a malfunction. Do not close the cassette lid until the cassette is ejected.

Note on moisture condensation

Moisture may condense when you bring your camcorder from a cold place into a warm place (or vice versa) or when you use your camcorder in a humid place as shown below.

- When you bring your camcorder from a ski slope into a place warmed up by a heating device.
- When you bring your camcorder from an air-conditioned car or room into a hot place outside.
- When you use your camcorder after a squall or a shower.
- When you use your camcorder in a hot and humid place.

How to prevent moisture condensation

When you bring your camcorder from a cold place into a warm place, put your camcorder in a plastic bag and seal it tightly. Remove the bag when the air temperature inside the plastic bag has reached the surrounding temperature (after about 1 hour).

Video head

- When the video head becomes dirty, you cannot record pictures normally, or distorted picture or sound is played back.
- If the following problem occurs, clean the video heads for 10 seconds with the Sony DVM-12CLD cleaning cassette (optional).
 - Mosaic-pattern noise appears on the playback picture or the screen is displayed in blue.



- Playback pictures do not move.
- Playback pictures do not appear or the sound breaks off.
- [X] Dirty video head. Use a cleaning cassette. [X] appears on the screen during recording.
- The video head suffers from wear after long use. If you cannot obtain a clear image even after using a cleaning cassette, it might be because the video head is worn. Please contact your Sony dealer or local authorized Sony service facility to have the video head replaced.

LCD screen

- Do not add excessive pressure on the LCD screen, as it may cause damage.
- If your camcorder is used in a cold place, a residual image may appear on the LCD screen. This is not a malfunction.
- While using your camcorder, the back of the LCD screen may heat up. This is not a malfunction.

To clean the LCD screen

If fingerprints or dust make the LCD screen dirty, it is recommended you use the cleaning cloth (supplied) to clean it. When you use the LCD Cleaning Kit (optional), do not apply the cleaning liquid directly to the LCD screen. Use cleaning paper moistened with the liquid.

On adjustment of the LCD screen (CALIBRATION)

The buttons on the touch panel may not work correctly. If this happens, follow the procedure below. It is recommended you connect your camcorder to the wall outlet using the supplied AC Adaptor during the operation.

- 1 Slide the **POWER switch up to OFF (CHG)**.
- 2 Eject the cassette from your camcorder, then disconnect any connecting cables except the AC Adaptor from your camcorder.
- 3 Slide the **POWER switch repeatedly to select the PLAY/EDIT mode while pressing DSPL/BATT INFO on your camcorder, then press and hold DSPL/BATT INFO for about 5 seconds.**
- 4 Touch the “X” displayed on the screen with the corner of the “Memory Stick” or the like.
The position of the “X” changes.

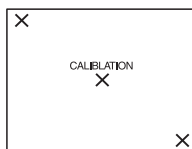

If you did not press the right spot, start from step 4 again.

→continued

Note

- You cannot calibrate the LCD screen if you have rotated the LCD panel and set it with the LCD screen facing out.

Cleaning the casing

- If the casing is soiled, clean the camcorder body with a soft cloth lightly moistened with water, and then wipe the casing with a dry soft cloth.
- Avoid the following to avoid damage to the finish.
 - Using chemicals such as thinner, benzine, alcohol, chemical cloths, repellent and insecticide.
 - Handling with above substances on your hands.
 - Leaving the case in contact with rubber or vinyl objects for a long period of time.

About care and storage of the lens

- Wipe the surface of the lens clean with a soft cloth in the following instances:
 - When there are fingerprints on the lens surface.
 - In hot or humid locations
 - When the lens is exposed to salty air such as at the seaside.
- Store in a well-ventilated location subject to little dirt or dust.
- To prevent molds periodically clean the lens as described above.

It is recommended you operate your camcorder about once a month to keep it in an optimum state for a long time.

To charge the pre-installed button-type battery

Your camcorder has a pre-installed button-type battery to retain the date, time, and other settings even when the POWER switch is set to OFF (CHG). The pre-installed button-type battery is always charged while you are using your camcorder but it will get discharged gradually if you do not use your camcorder. The button-type battery will be fully discharged in about **3 months** if you do not use your camcorder at all. However, even if the pre-installed button-type battery is not charged, the camcorder operation will not be affected as long as you are not recording the date.

Procedures

Connect your camcorder to a wall outlet using the supplied AC Adaptor, and leave it with the POWER switch set to OFF (CHG) for more than 24 hours.

Specification

Video camera recorder

System

Video recording system

2 rotary heads, Helical scanning system

Audio recording system

Rotary heads, PCM system

Quantization: 12 bits (Fs 32 kHz, stereo 1, stereo 2), 16 bits (Fs 48 kHz, stereo)

Video signal

NTSC color, EIA standards

Usable cassette

Mini DV cassette with the ^{Mini} **DV** mark printed

Tape speed

SP: Approx. 18.81 mm/s

LP: Approx. 12.56 mm/s

Recording/playback time (using a DVM60 cassette)

SP: 60 min

LP: 90 min

Fast forward/rewind time (using a DVM60 cassette)

Approx. 2 min 40 s

Viewfinder

Electric viewfinder (black and white)

Image device

3 mm (1/6 type) CCD (Charge Coupled Device)

Gross: Approx. 680 000 pixels

Effective (movie): Approx. 340 000 pixels

Lens

Carl Zeiss Vario Tessar

Combined power zoom lens

Filter diameter: 25 mm (1 in.)

10 × (Optical), 120 × (Digital)

F = 1.7 ~ 2.3

Focal length

2.3 - 23 mm (3/32 - 29/32 in.)

When converted to a 35 mm still camera

In CAMERA:

43 - 430 mm (1 3/4 - 17 in.)

Color temperature

[ AUTO], [ONE PUSH], [INDOOR] (3 200 K), [OUTDOOR] (5 800 K)

Minimum illumination

5 lx (lux) (F 1.7)

0 lx (lux) (during the NightShot plus function)*

* Objects unable to be seen due to the dark can be shot with infrared lighting.

Input/Output connectors

Audio/Video output

10-pin connector

Video signal: 1 Vp-p, 75 Ω (ohms), unbalanced

Luminance signal: 1 Vp-p, 75 Ω (ohms), unbalanced

Chrominance signal: 0.286 Vp-p, 75 Ω (ohms), unbalanced

Audio signal: 327 mV (at output impedance more than 47 kΩ (kilohms)), Output impedance with less than 2.2 kΩ (kilohms)

DV input/output

4-pin connector

LANC jack

Stereo mini-minijack (ø 2.5 mm)

USB jack

mini-B

MIC jack

Minijack, 0.388 mV low impedance with DC 2.5 to 3.0 V, output impedance 6.8 kΩ (kilohms) (ø 3.5 mm), Stereo type

LCD screen

Picture

6.2 cm (2.5 type)

Total dot number

123 200 (560 × 220)

General

Power requirements

DC 7.2 V (battery pack)

DC 8.4 V (AC Adaptor)

Average power consumption (when using the battery pack)

During camera recording using the viewfinder
2.2 W

During camera recording using the LCD
2.5 W

Operating temperature

0°C to 40°C (32°F to 104°F)

Storage temperature

-20°C to +60°C (-4°F to +140°F)

Dimensions (approx.)

50 × 86 × 112 mm (2 × 3 1/2 × 4 1/2 in.) (w/h/d)

Mass (approx.)

380 g (13 oz) main unit only
440 g (15 oz) including the NP-FP50
rechargeable battery pack and DVM60
cassette.

Supplied accessories

See page 11.

AC Adaptor AC-L25A/L25B**Power requirements**

AC 100 - 240 V, 50/60 Hz

Current consumption

0.35 - 0.18 A

Power consumption

18 W

Output voltage

DC 8.4 V, 1.5 A

Operating temperature

0°C to 40°C (32°F to 104°F)

Storage temperature

-20°C to +60°C (-4°F to +140°F)

Dimensions (approx.)

56 × 31 × 100 mm (2 1/4 × 1 1/4 × 4 in.) (w/h/
d) excluding the projecting parts

Mass (approx.)

190 g (6.7 oz) excluding the power cord

Rechargeable battery pack (NP-FP50)**Maximum output voltage**

DC 8.4 V

Output voltage

DC 7.2 V

Capacity

4.9 Wh (680 mAh)

Dimensions (approx.)

31.8 × 18.5 × 45.0 mm
(1 5/16 × 3/4 × 1 13/16 in.) (w/h/d)

Mass (approx.)

40 g (1.5 oz)

Operating temperature

0°C to 40°C (32°F to 104°F)

Type

Lithium ion

Design and specifications are subject to change
without notice.

Identifying parts and controls

Camcorder

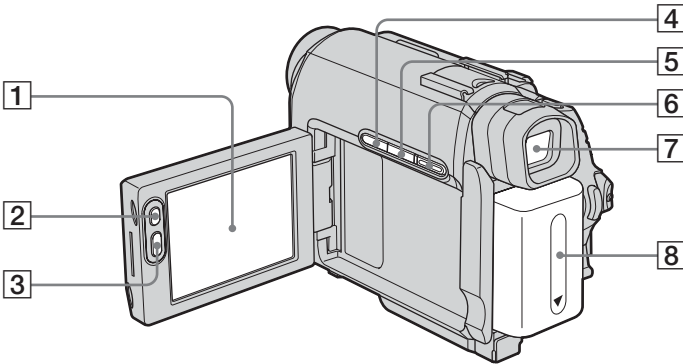

- 1** LCD/Touch panel screen (p. 3, 16)
- 2** LCD BACKLIGHT button* (p. 16)
- 3** REC START/STOP button (p. 21)
- 4** BACK LIGHT button* (p. 26)
- 5** DSPL/BATT INFO button (p. 13, 37)
- 6** EASY button (p. 25, 36)
- 7** Viewfinder (p. 3, 16)
- 8** Battery pack (p. 12)

* These buttons are not available during Easy Handycam operation. (There is the ● mark.)

→ continued

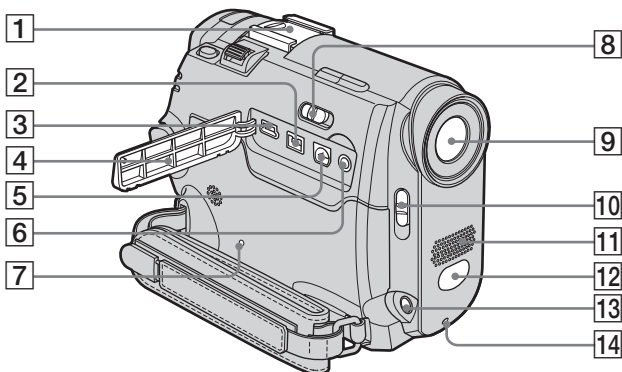

- 1 Accessory shoe/Shoe cover (p. 69)**
Remove the shoe cover and extend the viewfinder when attaching/detaching the accessory to/from your camcorder. The accessory shoe has a safety device for fixing the installed accessory securely. To connect an accessory, press down and push it to the end, and then tighten the screw. To remove an accessory, loosen the screw, and then press down and pull out the accessory.

- 2 DV Interface (p. 85)**

- 3 USB jack**

- 4 Jack cover**

- 5 A/V OUT jack (p. 62)**

- 6 LANC jack (blue)**

The LANC control jack is used for controlling the tape transport of video device and peripherals connected to it.

- 7 RESET button**

If you press RESET, all the settings including the date and time, return to the default.

- 8 NIGHTSHOT PLUS switch (p. 29)**

- 9 Lens (Carl Zeiss Lens)/Lens cover**

Your camcorder is equipped with a Carl Zeiss lens which can reproduce fine images. The lens for your camcorder was developed jointly by Carl Zeiss, in Germany, and Sony Corporation. It adopts the MTF measurement system for video cameras and offers a quality as fine as a Carl Zeiss lens. MTF stands for Modulation Transfer Function. The value number indicates the

amount of light from a subject coming into the lens.

- 10 LENS COVER switch**

- 11 Microphone (p. 69)**

- 12 Remote sensor/Infrared ray emitter (p. 65)**

- 13 MIC (PLUG IN POWER) jack (red) (p. 69)**

This jack works as an input for an external microphone as well as a power-supply jack for a plug-in-power microphone. When the external microphone is connected, it takes precedence.

- 14 Camera recording lamp (p. 21)**

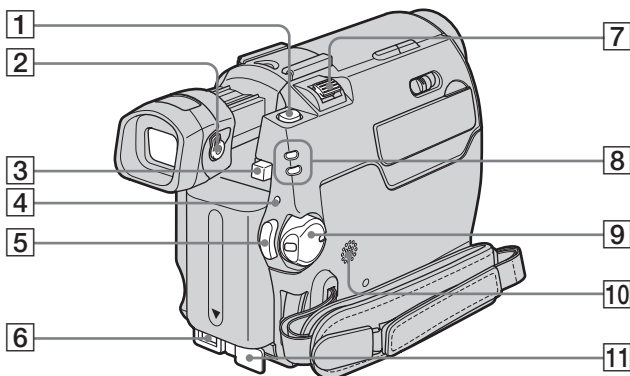

- 1** PHOTO button (p. 24)
- 2** Viewfinder lens adjustment lever (p. 16)
- 3** BATT (battery) release button (p. 13)
- 4** CHG (charge) lamp (p. 12)
- 5** REC START/STOP button (p. 21)
- 6** DC IN jack (p. 12)
- 7** Power zoom lever
- 8** CAMERA, PLAY/EDIT mode lamps (p. 15)
- 9** POWER switch (p. 15)
- 10** Speaker
- 11** DC IN jack cover

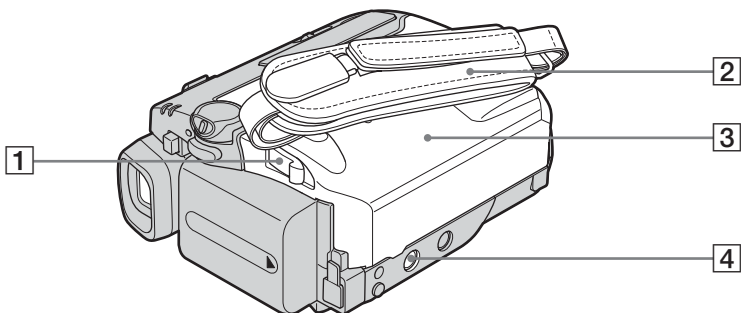

1 OPEN/EJECT lever (p. 19)

2 Strap Belt

3 Cassette lid (p. 19)

4 Tripod receptacle

Make sure that the length of the tripod screw is less than 5.5 mm (7/32 inch). Otherwise, you cannot attach the tripod securely, and the screw may damage your camcorder.

3 Use the Strap Belt as shown below.

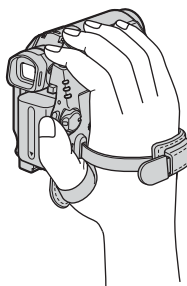

Using the Strap Belt as a wrist strap

It is useful when you carry your camcorder.

1 Open the hook and loop fastener of the hand pad (1) and remove it from the ring (2).

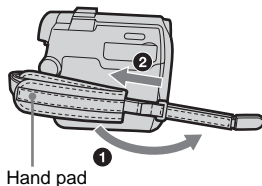

2 Move the hand pad fully to the right (1), then close the hook and loop fastener again (2).

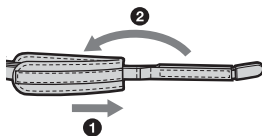

Remote Commander

Remove the insulation sheet before using the Remote Commander.

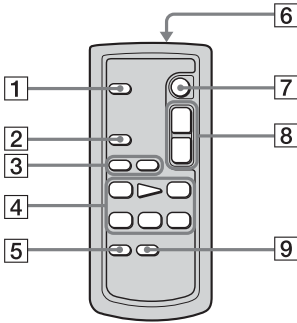

- 1 PHOTO button** (p. 24)
- 2 SEARCH M. button*** (p. 40)
- 3 ◀▶ buttons*** (p. 40)
- 4 Video control buttons** (Rewind, Playback, Fast-forward, Pause, Stop, Slow) (p. 35)
- 5 ZERO SET MEMORY button*** (p. 40)
- 6 Transmitter**
After turning on your camcorder, point towards the remote sensor to control your camcorder.
- 7 REC START/STOP button** (p. 23)
- 8 Power zoom button** (p. 22)
- 9 DISPLAY button** (p. 40)

* These buttons are not available during Easy Handycam operation.

To remove the insulation sheet

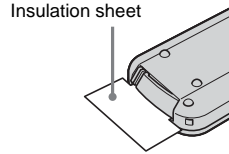

To change the button-type battery

- 1** While pressing on the tab, insert your fingernail into the slit to pull out the battery case.

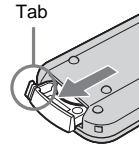

- 2** Remove the button-type lithium battery.

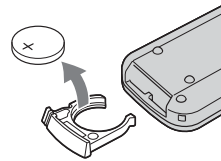

- 3** Place a new button-type lithium battery with the + side facing up.

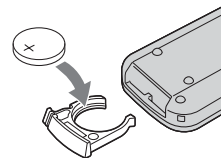

- 4** Insert the battery case back into the Remote Commander until it clicks.

→ continued

WARNING

Battery may explode if mistreated. Do not recharge, disassemble or dispose of in fire.

🔌 Notes on the Remote Commander

- A button-type lithium battery (CR2025) is used in the Remote Commander. Do not use batteries other than CR2025.
- Point the remote sensor away from strong light sources such as direct sunlight or overhead lighting. Otherwise, the Remote Commander may not function properly.
- The Remote Commander may not function properly when the remote sensor is obstructed with a conversion lens (optional).
- When you are operating with the Remote Commander supplied with your camcorder, your VCR may also operate. In that case, select a commander mode other than VTR 2 for your VCR, or cover the sensor of your VCR with black paper.

Indicators for the LCD screen and viewfinder

Following indicators will appear on the LCD screen and viewfinder to indicate the state of your camcorder.

Example: Indicators in the CAMERA mode

Time code (p. 22)/Tape counter (p. 22)/Self-diagnosis (p. 78)

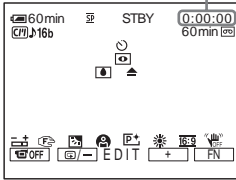

Indicators	Meanings
	Back light (p. 26)
	White balance (p. 27)
16:9	16:9WIDE (p. 47)
	SteadyShot off (p. 48)
	LCD backlight off (p. 16)

Indicators	Meanings
	Remaining battery (p. 21)
SP LP	Recording mode (p. 22)
PAL	PAL system video (p. 76)
STBY REC	Recording standby/ recording mode
	Cassette Memory (p. 82)
J16b	Audio mode (p. 55)
60min	Remaining tape (p. 21)
	Self-timer recording (p. 23)
	Tape photo recording (p. 24)
	Frame recording (p. 55)
	Interval recording (p. 56)
DVIN	DV input (p. 63)
+0+	Zero set memory (p. 40)
	NightShot plus (p. 29)
	Warning (p. 78)
	Picture effect (p. 45)
	Manual exposure (p. 28)
	Manual focus (p. 30)
	PROGRAM AE (p. 44)

Index

Numerics

16:9WIDE mode 47

A

A/V connecting cable.. 39, 62

AC Adaptor 14

Adjusting the viewfinder... 16

Audio dubbing (A DUB
CTRL)..... 69

AUDIO MIX 50, 70

AUDIO MODE 55

Auto shut off function
(A.SHUT OFF)..... 60

Auto shutter (AUTO SHTR)
..... 46

B

BACK LIGHT (camera).... 26

Battery

Battery Info..... 13

Battery pack..... 12

Remaining battery
..... 21, 84

BEEP 16, 60

Black fader (BLACK) 31

BURN DVD 71

BURN VCD 71

Button-type battery

Camcorder 88

Remote Commander... 95

C

CALIBRATION..... 87

Camera settings data display
..... 37

Cassette 19

Cassette Memory..... 3, 82

Cassette Memory Search (CM
SEARCH) 32, 40, 54

Charging the battery

Battery pack..... 12

Pre-installed button-type
battery 88

Clock set (CLOCK SET)
..... 17

D

Data code (DATA CODE)
..... 37

Date search..... 41

Demonstration (DEMO
MODE)..... 58

Digital program editing
(VIDEO EDIT) 64

Digital Zoom (D ZOOM)
..... 47

Direct Access to “Click to
DVD”
See BURN DVD

Direct Access to Video CD
Burn
See BURN VCD

Display
DISPLAY 61

Display indicators 97

Dual sound track tape 50

Dubbing (REC CTRL)..... 63

E

Easy Handycam 25, 36

EDIT SEARCH 32

END SEARCH 32

Erase

ERASE ALL (Cassette
Memory)..... 54

F

FADER 31

Flexible spot meter (SPOT
METER)..... 26

Frame playback..... 35

Frame recording (FRAME
REC)..... 55

Full charge 12

G

Grip belt

See Strap Belt

H

HiFi SOUND 50

I

i.LINK..... 85

i.LINK cable 62, 64

ID-1 47

ID-2 47

“InfoLITHIUM” battery pack
..... 83

Infrared ray emitter..... 65

Interval recording (INT.REC)
..... 56

L

LANC 92

Language (LANGUAGE)
..... 20, 58

LCD back light (LCD B.L.)
..... 51

LCD BACKLIGHT..... 16

LCD brightness (LCD BRT)
..... 16

LCD COLOR 51

LCD screen..... 3

LP (Long Play)

See Recording mode (REC
MODE)

M

Main sound

See HiFi-SOUND

Manual exposure

(EXPOSURE) 28

Manual focus (FOCUS) 30

Menu

CAMERA SET 47

CM SET 52

LCD/VF SET 51

MANUAL SET..... 44

OTHERS..... 60

SETUP MENU 58

TAPE SET 55

VCR SET 50

Mirror mode 22

Moisture condensation 86

MONOTONE 31

Mosaic fader (MOSC.

FADER)..... 31

N

NightShot Light (NS LIGHT)

..... 29, 49

NightShot plus..... 29

NTSC..... 81

O	
Operation confirmation beep	
See BEEP	
P	
PAL	81
Photo scan	42
Photo search	41
Picture effect (P EFFECT)	
.....	45
Picture search	35
Playback (V SPD PLAY)	
Double speed	35
Frame.....	35
Reverse	35
Slow.....	35
Playing time	14
Power mode	15
PROGRAM AE	44
R	
Rec review	33
REC START/STOP	21
Recording capacity	
Display	22
REMAIN	55
Recording lamp (REC LAMP)	
.....	61
Recording mode (REC	
MODE).....	21, 55
Recording time.....	13
Remote Commander	95
COMMANDER	60
Remote sensor.....	92
RESET	92
S	
S video	39, 62
Self-diagnosis display	78
Self-timer recording (SELF-	
TIMER).....	23
Skip scan	35
Smooth transition	
See END SEARCH	
SP (Standard Play)	
See Recording mode (REC	
MODE)	
SPOT FOCUS	29
STEADYSHOT	48
Stereo/monaural	50
Strap Belt	4, 94
Sub sound	
See HiFi-SOUND	
T	
Tape counter	22
Tape photo recording.....	24
Telephoto	
See Zoom	
Time code	22
Title (Cassette Memory)	
TAPE TITLE	54
TITLE	52
TITLE DSPL	53
TITLEERASE.....	53
Title search	40
TV color systems.....	81
U	
USB jack.....	92
USB Streaming (USB	
STREAM).....	58
Using abroad.....	81
V	
Video head.....	87
Viewfinder.....	16
Brightness (VF B.L.) ..	51
Volume (VOL)	34
W	
Warning indicators	78
Warning messages	80
White balance (WHT BAL)	
.....	27
White fader (WHITE)	31
Wide angle	
See Zoom	
WORLD TIME.....	60
Wrist strap	
See Strap Belt	
Write-protect tab.....	82
Z	
Zero set memory.....	40
Zoom	22

<http://www.sony.net/>



Printed on 100% recycled paper using
VOC (Volatile Organic Compound)-free
vegetable oil based ink.

Printed in Japan



3088336110