

CONTAX T3

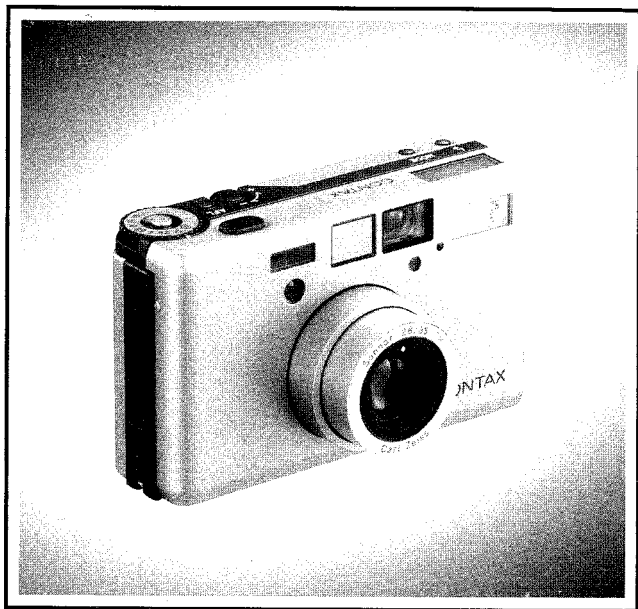

Instruction manual • Bedienungsanleitung

GB/D

Thank you for purchasing this Contax product. The Contax T3 has been designed according to the basic philosophy of providing the user with pleasure in handling, and use, as well as the production of fine photographs. Simple enough for casual use, it provides the controls needed for doing justice to those special occasions. The Contax T3 is a 35mm lens-shutter camera equipped with both automatic and manual focusing controls, programmed automatic and aperture-priority automatic exposure modes, long-time exposure mode, exposure compensation and a focus-lock feature.

Before using this camera, please read the instructions thoroughly to gain a correct understanding of camera features.

In addition to its standard features, this camera is equipped with "Custom Functions" which may be set manually if desired. See page 47 for further details. Custom Functions are indicated in the text by the **CF** mark.

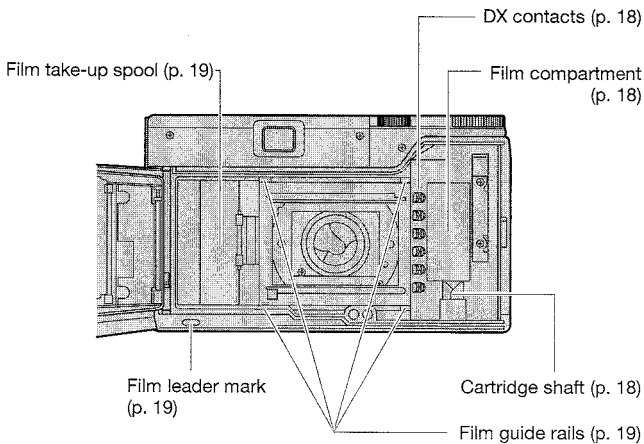
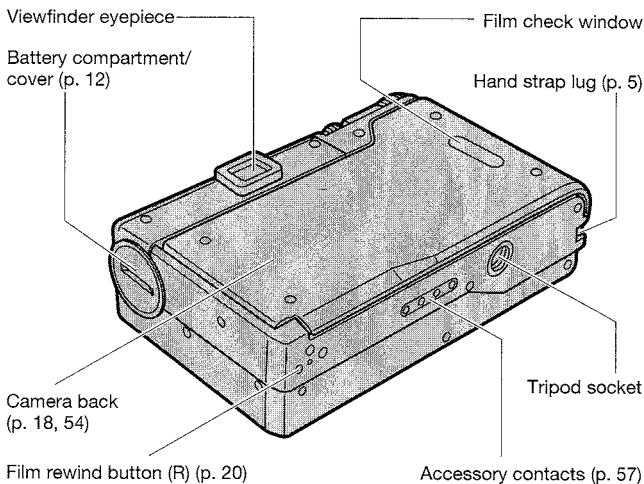

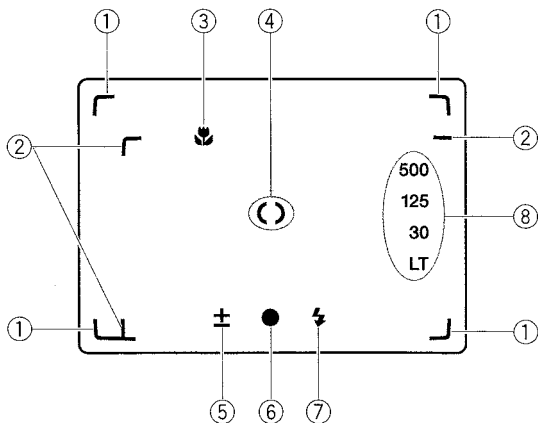

The Picture Area Frame ①, Close-up Parallax Frame ② and Focus frame ④ are always visible in the viewfinder, but other indicators appear only under the conditions indicated below, and automatically disappear after 8 sec to save battery power:

- 1) When the camera is turned ON.
- 2) With the camera is turned on, whenever the shutter release button is depressed halfway. (Also, when the “” or “AFL” buttons are depressed).

① Picture area frame

These marks indicate the outer borders of the image that will be recorded on film under normal conditions. (p. 24)

② Close-up Parallax Frame

These marks indicate the outer borders of the image that will be recorded on film when shooting at very close distances (approx. 0.8 m - 0.35 m). When shooting close-ups, be sure the subject fits within these marks.

③ Close-up (macro) indicator “”

Lights: When camera-to-subject distance is between approx. 0.8 m and 0.35 m.

Blinks: When camera-to-subject distance is too close (outside of focusing range).

(For purposes of explanation, all viewfinder indicators are shown here. The actual viewfinder display differs depending on conditions.)

④ **Focus Frame**

Indicates the part of the viewfinder used by the autofocus.
(p. 24)

⑤ **Exposure compensation indicator “±”**

Lights when exposure compensation is set (p. 38).

⑥ **Focusing indicator (indicates focusing status) “●”**

<Autofocus>

Lighted: Subject in focus

Blinks quickly (4 times/sec): Out of focus

Blinks slowly (once/sec): Focus locked via AFL button

<Manual Focus>

Blinks slowly (once/sec): Focusing distance set manually

⑦ **Flash indicator “⚡”**

Lighted: Flash will fire

Blinks quickly (4 times/sec): Outside the range of the built-in flash (image will be under-exposed)

Blinks slowly (once/sec): Flash is recharging

⑧ **Shutter speed**

Indicates the current shutter speed, as follows:

Viewfinder display	Shutter speed
500 blinking	Over-exposure
	1/1200 sec
500 lighted	1/350 sec
500 and 125 lighted	1/180 sec
125 lighted	1/90 sec
125 and 30 lighted	1/45 sec
30 lighted	1/20 sec
LT lighted	16 sec
LT blinking	Long Time exposure mode (p. 42)

Display Panel

(For purposes of explanation all indicators are shown here; the actual display contents differ depending on photographic conditions.)

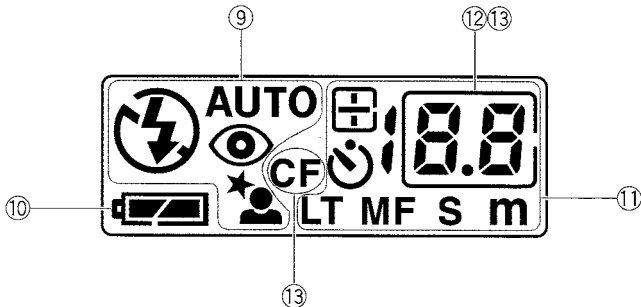

⑨ Flash Mode (p. 16, 26)

Automatic Flash Mode: “⚡^{AUTO}”

Red-Eye Reduction Flash Mode: “⚡^{AUTO} 👁”

No-Flash Mode: “⚡”

Fill-in flash Mode: “⚡”

Night Portrait Flash Mode: “⚡^{AUTO} 👤”

⑩ Display of battery capacity (p. 13)

⑪ Mode Indicators and Settings (p. 38-46)

Exposure compensation mode:
“⊕” or “⊖” and compensation value

Selftimer mode: “🕒” and timer setting

Long-time mode: “LT” and shutter setting

Focus setting mode: “AF” or “MF,” and setting distance

⑫ Exposure counter

(also displays remaining time for selftimer and long-time exposure).

⑬ Custom function mode: “CF” and setting item

(Example: “⚡”) (p. 47)

Camera Preparations

1. Loading Battery

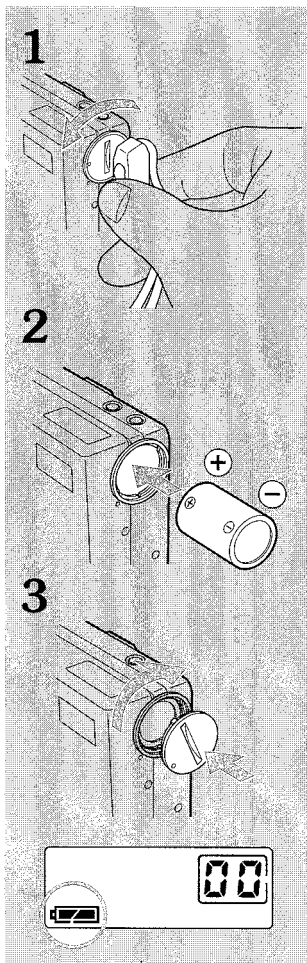

1 Open battery compartment cover

Using the hand strap adjuster as shown, turn the battery compartment cover counter-clockwise, so that its “•” mark is aligned with the “•” mark on the camera body.

2 Insert new battery

Be sure the battery poles are oriented correctly as indicated inside the battery compartment. A single 3V lithium battery (type CR2) is required.

3 Close the battery compartment by aligning the “•” mark on the cover with the “•” mark on the camera body and rotating the cover clockwise.

<Battery Check>

After inserting a new battery, operate the camera once; the battery charge indicator “” should appear in the display panel.

Display of battery capacity



Battery is full



New battery will be needed shortly

(Blinking)



Replace battery as soon as possible





(Blinking)



Battery is empty

<Battery Replacement>

The battery should be replaced when the battery charge indicator “” blinks in the display panel. Turn off the camera before replacing the battery.

- Photographs can still be taken even when the remaining battery power indicator “” begins to blink, but the battery should nonetheless be changed as soon as possible. If the remaining battery power falls below a certain point, the “” mark on the display panel will blink and the camera will not operate.
- Due to individual manufacturing characteristics, some batteries may cause the battery power indicator “” to blink temporarily after the battery is changed. If this occurs immediately after changing a battery, turn the power switch OFF and then ON again; if the full battery power indicator “” appears when the camera is turned on again, the battery can be used without problems.

2. Pressing the Shutter Release Button

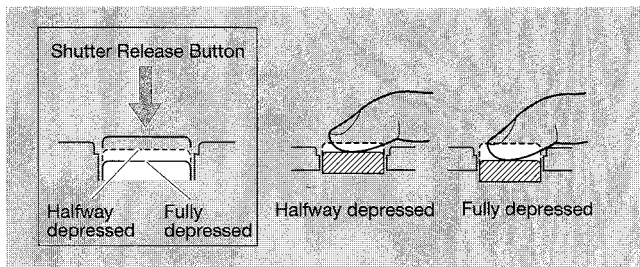

The shutter release button is designed to be pressed in two stages, the "halfway depressed" position, and the "fully depressed" position. In the two positions, the shutter release button operates as follows:

Halfway depressed:

Lens is focused and light on subject is metered.

Fully depressed:

Lens is extended to focusing position, shutter released, picture taken and the film is wound to next frame.

* To prevent camera shake, press the shutter release button gently with the pad of your index finger. Be sure to observe how to hold the camera correctly as well (see p. 15).

CF If desired, the camera may be set so that the lens will extend to the focus position when the shutter release button is in the halfway depressed position (p. 47).

3. How to Hold the Camera Correctly



Horizontal position



Vertical position

- ① Hold your elbows close to your body to stabilize the camera.
- ② Hold your breath as you squeeze the shutter release button.
- ③ Don't grasp the camera too tightly, and press the shutter release button gently.

In order to assure well-focused photographs, it is important to grasp the camera firmly and securely. Most poorly focused photographs are caused by "camera shake" (movement of the camera during exposure).

In addition to the normal horizontal position, the camera may also be held vertically. But in both cases you should try to find the best holding posture for your needs. If possible lean against a wall or a tree etc or rest the camera on a stable surface.

- When shooting, be careful not to allow your fingers or camera strap to block the camera lens, rangefinder window, light sensor, AF assist light, or electronic flash.
- When taking vertical-composition pictures, holding the camera with the flash at the top will help produce photographs with the most natural lighting.

When grasping the camera, take care not to touch the lens barrel.

4. Main Switch / Aperture Dial

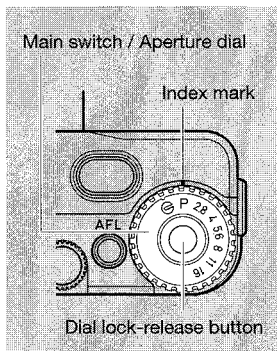

The Main Switch/Aperture Dial is used to turn the camera ON/OFF, and for setting the aperture value when using the aperture-priority automatic exposure mode.

When the main switch is turned from "⊖" to "P", the camera is turned ON and ready for use in the programmed automatic exposure mode (p. 23, 35). By holding the dial lock-release button depressed and turning the dial to one of the aperture values in the range "2.8-16," the camera will be set for aperture-priority automatic exposure (p. 36).

5. Flash Mode Button

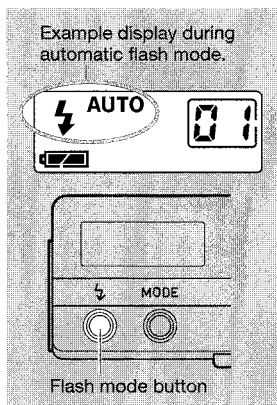

The flash mode button is used to select the flash mode.

After the camera is switched ON, each time you press the flash mode button the flash mode is changed in the order shown below; the corresponding mode is indicated on the display (p. 26).



- ① Automatic Flash mode "⚡ AUTO"
- ② Red-eye-reduction Flash mode "⚡ AUTO" (with a red-eye-reduction icon)
- ③ No-flash mode "⊖"
- ④ Fill-in Flash mode "⚡"
- ⑤ Night Portrait Flash Mode "⚡ AUTO" (with a night portrait icon)

- The default flash mode (the mode set automatically when the camera is turned on) can be changed if desired (p. 30).

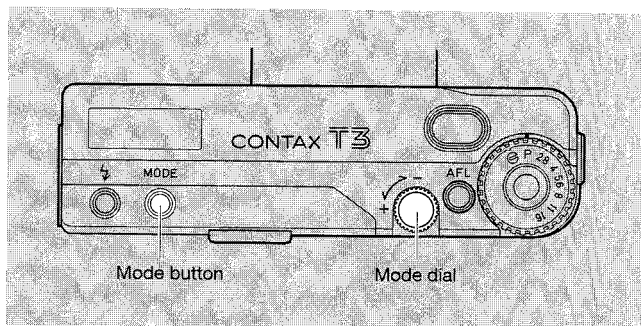
6. Mode Button and Mode Dial



Using the mode button and mode dial allows the use of a wide variety of photographic techniques. For details, see p. 38-46. The mode button is used to switch between the modes shown in the accompanying table, and the mode dial is used to change the set values in each mode.

Order	Display	Mode	Setting Contents
①	 or 	Exposure compensation (p. 38)	Compensation value: -2EV - +2EV
②		Selftimer (p. 40)	Delay time: 10 sec or 2 sec
③	LT	Long-time exposure (p. 42)	Shutter time: 1-180 sec
④	AF or MF	Focus mode select and distance set.	Distance: 0.4m-infinity, AF

7. Loading Film

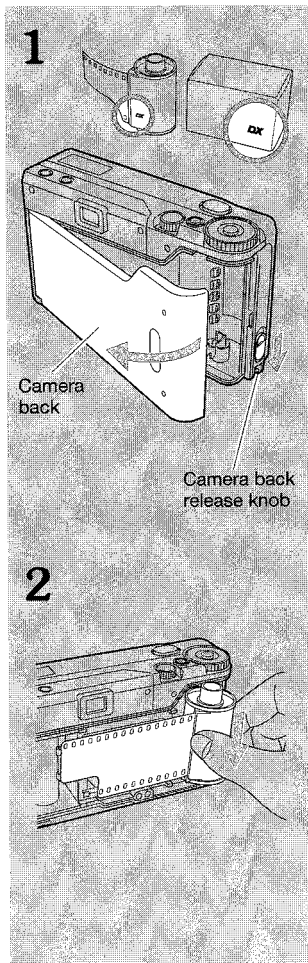

Use DX-coded 35mm film. The film speed is automatically set by the camera.

- Non-DX-coded film is automatically set to ISO 100.

1 Open the camera back.

Open the camera back by pushing down the camera back release knob.

- Load and unload film away from direct sunlight.

2 Insert a new film

Insert the cartridge diagonally as shown in the illustration.

- Take care not to handle the DX contacts excessively, or allow them to become soiled.

3

Film guide rails

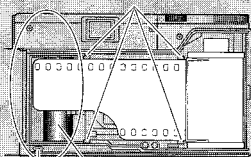

Film take-up spool

Film leader mark

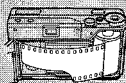
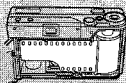

3 Pull out the film leader from the cartridge until it reaches the orange colored “” (film leader mark), and lay the film leader on top of the take-up spool.

When pulling out the film leader, do not pull out too much so that the film buckles.

- If you accidentally pull out too much film, adjust the length before continuing.

4

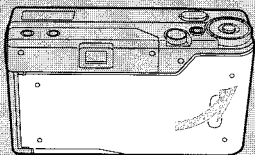

4 Close the camera back securely.

When the camera back is closed, the film automatically advances to the first frame and stops with the exposure counter at “01”.

If the exposure counter displays a blinking “00”, the film is not advancing properly; the shutter will not operate in this condition. Open the camera back and load the film correctly.

8. Removing Exposed Film

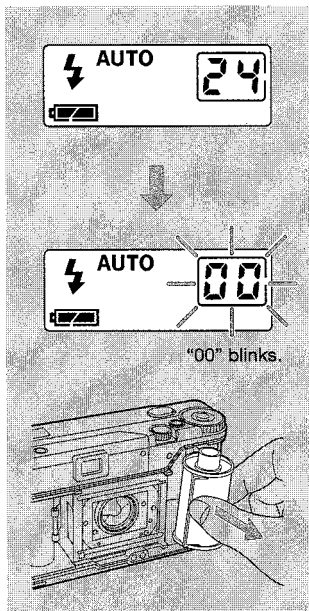

When the final frame of a roll has been exposed, the camera automatically rewinds the film into the cartridge.

During rewinding, the exposure counter displays decreasing numbers until rewind is complete, at which point the motor stops and the exposure counter shows a blinking "00". When rewind is complete, open the camera back and remove the film cartridge.

Never attempt to open the camera back until rewinding is complete.

- After film is rewind, the camera will not operate again until the camera back is opened.
 - To manually rewind film mid-way through a roll, use the tip of the adjuster on the accessory strap (or other pointed object) to depress the rewind button "R". (Do not use an awl, needle, or other very sharp instrument).
- CF** If desired, the camera can be set to leave the film leader outside the film cartridge after rewind is completed (p. 47).

9. Basic Photographic Terms and Information

<Aperture>

The aperture in the lens controls the amount of light going through the lens by becoming smaller or larger. The size of the opening is called aperture value. The larger the aperture value the smaller the opening.

<Shutter speed>

By varying the amount of time it remains open, the camera's shutter controls the amount of light reaching the film. The length of time the shutter remains open is called the shutter speed.

<Exposure>

"Exposure" means to expose the film to light. The amount of light allowed to strike the film is controlled by the combination of aperture and shutter speed.

<Film speed> (ISO value)

The film speed refers to a given film's sensitivity to light, measured according to numerical values established by the International Standards Organization (ISO). The smaller the ISO value, the lower the film's sensitivity to light.

The larger the ISO value, the higher the film's sensitivity to light (the film is sensitive to lower levels of light).

<Depth-of-field>

In general, when the lens is focused on a given subject, not only the subject itself, but a certain area in front of and behind the subject will also be in focus. The range between the nearest and the farthest point that is sharp is the "depth-of-field." The depth-of-field on any given lens will change in the following way:

- ① As the aperture is closed, the depth-of-field becomes larger, and as the aperture is opened, the depth-of-field becomes smaller.
- ② The depth of field becomes larger as distance to the subject increases, smaller at closer distances.
- ③ The depth of field is larger behind than in front of the subject in focus.

Basic Camera Techniques

1. Turn on the Camera

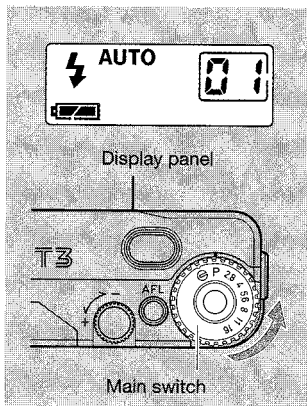

Turn the main switch from “” to “P”.

The camera is turned on, the lens barrier automatically opens, and the lens extends to its shooting position. The camera automatically defaults to the following modes:

1. Focusing → automatic focus

The camera lens automatically focuses whenever the shutter release button is depressed halfway.

2. Exposure → Programmed automatic exposure “P”

The camera automatically selects the optimum combination of shutter speed and aperture for the ambient lighting conditions. This mode is ideal for snapshots.

3. Flash mode → automatic flash mode “ AUTO ”

In this mode, the flash fires automatically when shooting in dark or strongly backlit situations. When the shutter release button is depressed halfway, the viewfinder display will show the “” mark if the flash is going to fire.

- Whenever you do not intend to use the camera immediately, turn off the main switch to prevent accidental tripping of the shutter.

2. Taking Pictures

1

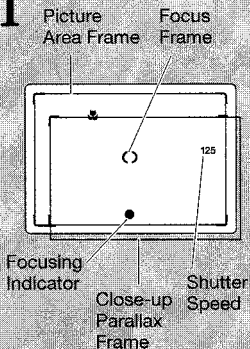

1 Point the viewfinder's focus frame at the subject and depress the shutter halfway.

The camera will focus, and when the subject is in focus, the "●" mark will appear inside the viewfinder, together with the automatically selected shutter speed.

- If the "🌸" mark lights, compose your subject inside the close-up parallax frame before shooting (p. 8).

2

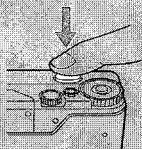

2 Gently press the shutter release button the rest of the way to take the photograph.

This camera focuses by means of an external, passive-type multi-autofocus. As a result, the subject should remain in focus even if it leaves the focusing frame slightly.

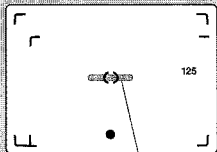
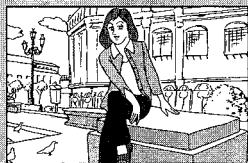

Multi-focus range

- If the “⚡” mark lights when the shutter release button is depressed halfway, the camera's exposure meter has determined that the subject has insufficient available light, and the flash will be triggered automatically when the shutter is released. If the “⚡” mark blinks quickly (4 times/sec), the subject is outside the effective flash operating range. Refer to the table on page 29 and approach your subject closer until the blinking indicator lights steadily.
- If the “🌸” mark blinks when the shutter release button is depressed halfway, the distance between camera and subject is too close; the shutter will not operate in this condition. Move farther from the subject (minimum 0.35 m) and try again.
- If the camera is unable to lock focus on the desired subject, the “●” indicator will blink rapidly and the shutter will not operate. Try focusing on another object located at the same distance from the camera then, while continuing to depress the shutter release button halfway, train the camera on the subject again and take the picture.
- If the “500” blinks inside the viewfinder display, the subject is too bright for the camera's automatic exposure capability and will be overexposed.

Autofocus (AF) Assist Light

When focusing on a dim or low-contrast subject, the AF assist light window emits a beam of infrared light to improve the accuracy of the camera's autofocus mechanism.

The effective range of AF assist light is about 4.7 meters.

3. Flash Photography

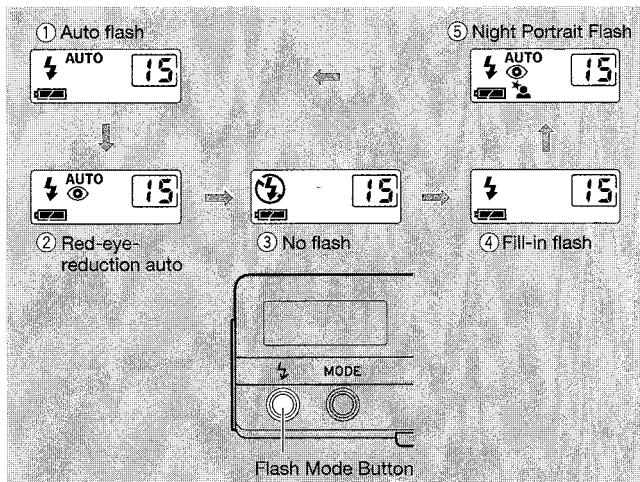

The flash mode can be selected to match your photographic needs, in accordance with the ambient light.

When the camera is ON, each time you press the flash mode button the flash mode changes in the following order, and is shown in the display:

- ① Auto flash → ② Red-eye-reduction auto flash →
③ No flash → ④ Fill-in flash → ⑤ Night Portrait Flash

The default flash mode (the mode set automatically when the camera is turned on) can be changed if desired. This custom function is convenient for setting the flash mode you use most commonly. For more details see p. 30, "Default Flash Setting"

<1. Auto Flash Mode> “ AUTO ”

In this mode, whenever the camera's light meter determines that available light conditions would result in a shutter speed slower than 1/60 sec, the flash fires automatically.

- When the flash is set to fire, the “ ” mark appears in the viewfinder.

<2. Red-Eye-Reduction Auto Flash Mode> “ AUTO ”

When taking flash photos of people and animals in dark surroundings, the pupils of the subject's eyes may appear red in the photograph due to the reflection of the flash on the background of the eyes.

- When this mode is selected, the flash unit fires twice at an interval of about 0.7 sec. The shutter is tripped only at the time of the second flash. Between the first and second flash, the finder display will show the blinking “●” mark and the selftimer LED. When using this mode, take care to avoid movement of the camera or subject between the two flashes.

<3. No Flash Mode> “ ”

Use this mode when you wish to take photographs without flash, in order to preserve the atmosphere of, for instance, idyllic sunsets or interior subjects. Exposure will be automatically set in accordance with the brightness of the subject, thus capturing the scene's natural ambience.

- When taking pictures of low-light subjects, exposure times may be very long (maximum 16 sec). Use of a tripod is strongly recommended to prevent camera shake.
- When using this mode, the flash mode indicator “ ” will not appear even if the scene is dark.

<4. Fill-in Flash Mode> “ ”

This mode forces the flash to fire, regardless of the amount of available light. In outdoor photography, portrait pictures in bright sunlight or backlight may appear very dark or silhouetted due to the strong light sources behind or around the subject. In such cases, using the fill-in flash mode will add light to illuminate the main subject, thus making both subject and background appear more natural. (Daylight Synch Photography)

- When the subject is in shadow and the proper shutter speed would ordinarily fall below 1/60th sec, using the fill-in flash mode will cause the shutter to be set automatically at 1/60th sec.

<5. Night Portrait Flash Mode> “ ”

When photographing people against sunsets or skylines, using this mode will help preserve the atmospheric background while providing sufficient flash to illuminate the subject.

In addition to the red-eye-reduction flash mode, the shutter speed is extended (to maximum 1 sec) to allow adequate exposure of the background (Slow Synch Photography).

- Since the shutter speed is extended when using slow synch photography, the use of a tripod is recommended to prevent camera shake.

Backlight Automatic Flash Photography

When using the Auto-flash mode, Red-Eye-Reduction Auto Flash mode, or Night Portrait mode and the subject is in strong backlight, the flash may fire automatically in order to provide well-balanced illumination.

- When the flash is activated, the “  ” mark lights in the viewfinder display.

If you frequently take flash photos over longer distances we recommend ISO 400 film, as it allows a greater flash range. (p. 29).

Notes about Flash Photography

- The “” mark in the viewfinder has the following meanings:



Lighted steadily (when shutter release button is depressed halfway): Flash will fire when the shutter release button is pressed. Subject is within effective flash range.

Blinks slowly (1 time/sec): Flash is recharging (shutter will not operate until recharging is completed).

Blinks rapidly (4 times/sec, when shutter release button is depressed halfway): Subject is outside effective flash range. The distance to subject is too far; if the picture is taken, it will be underexposed. Either approach closer to the subject or open the aperture until the blinking indicator lights steadily. The effective flash range is even narrower when using slide film, so refer to the accompanying “Effective Flash Range Table” when planning your photographs.

<Effective Flash Range> (For Slide Film)

Exposure/Aperture	Distance (m)	0.35	1	2	3	4
P		[Shaded bar from 0.35 to 4]				
F2.8		[Shaded bar from 0.35 to 4]				
F4		[Shaded bar from 0.35 to 3]				
F5.6		[Shaded bar from 0.35 to 2]				
F8		[Shaded bar from 0.35 to 1.5]				
F11		[Shaded bar from 0.35 to 1]				
F16		[Shaded bar from 0.35 to 0.7]				

 For ISO 400 film
 For ISO 100 film

When using the aperture priority automatic mode, the flash output will change in accordance with the camera-to-subject distance. When using the programmed auto mode “P”, the flashmatic system is used, and the camera’s aperture changes in accordance with the camera-to-subject distance. **For flash photography, we recommend “P” mode. If you stop down the aperture, the effective flash range will be substantially reduced.**

- If you wish to take flash photographs at distances beyond the effective range of the built-in flash, use the Contax flash adapter SA-2 (sold separately) together with the TLA200 flash unit (p. 57)

<Default Flash Setting>

The camera's default flash setting (the flash mode set whenever the camera is turned on) can be changed if desired. This feature is convenient if you most frequently use the "⚡" or "⚡" modes.

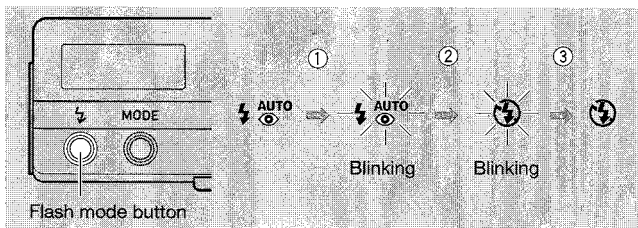

- ① With the camera turned on, hold the flash mode button depressed until the flash mode indicator "⚡^{AUTO}" begins to blink (about 2 sec).
 - ② Once the indicator starts blinking, let go of the button, then press it again to select the desired default flash mode.
 - ③ After selecting the desired default mode, release the button and about 8 sec later, the flashing indicator will light steadily, indicating that the new mode has been set.
- The mode will remain set when the shutter release button is depressed halfway or when camera power is turned off.

4. Focus Lock

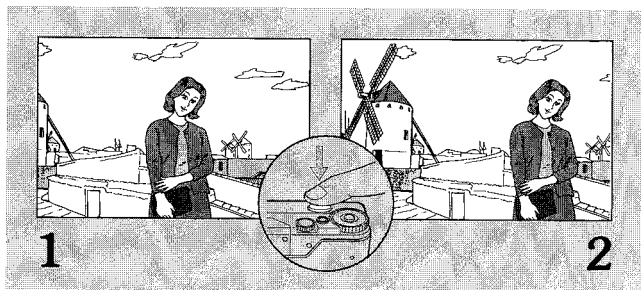

When the shutter button is depressed halfway, the lens is focused, and it remains focused at that distance as long as the shutter release button is held halfway depressed. This function is called “focus lock,” and it allows the user to recompose the picture without changing the point at which the lens is focused.

Sometimes the main subject may be located outside the central focus frame of the camera; in this case, use the “focus lock” function to first lock the focus on the subject, then return the camera to the desired composition and take the photograph.

1 Point the viewfinder’s focus frame at the desired subject and depress the shutter release button halfway.

The camera lens will focus on the subject and “●” will appear in the viewfinder to indicate that focus is locked.

- The display will show the distance at which the focus is locked. The distance will continue to appear in the screen for about 2 seconds after the shutter is released.
- Simultaneously with focusing, the camera will also measure and set the exposure value for the picture (AE lock).
- A quickly flashing “●” indicator (4 times/second) indicates that the camera cannot focus properly on the current subject. In this case, perform focus-lock on another object located at the same distance from the camera before taking the picture.

2 While holding the shutter release button depressed halfway, move the camera to compose the photograph as desired, and then press down the shutter release button fully to take the picture.

- Focus lock will be released by removing your finger from the shutter release button.

5. AFL Button

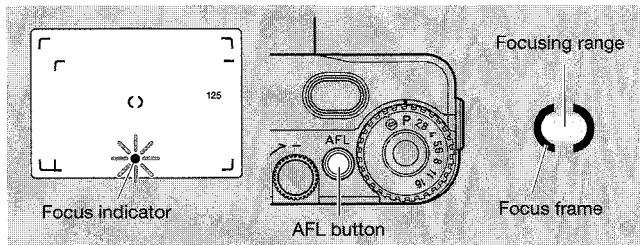

The AFL button can be used to manually achieve focus lock. Since the shutter release button needs to be used only when making a photograph, it allows you to concentrate on getting the best shot. The range in focus is determined by the focus frame (spot, AF).

1 Point the viewfinder's focus frame at the desired subject and press the AFL button for about 1.5 sec or more, until the "●" indicator blinks slowly (1 time/sec). When the "●" indicator blinks, the focus is locked on the subject and you can let go of the AFL button.

- The display will show the distance at which the focus is locked.
- A quickly flashing "●" indicator (4 times/second) indicates that the camera cannot focus properly on the current subject. In this case, perform focus-lock on another object located at the same distance from the camera before taking the picture.

Pressing the AFL button again will release focus lock.

2 Move your camera as necessary to compose the photograph as desired, and press the shutter release.

- Once the shutter has tripped, the focus lock is released.

CF If desired, the focus lock function can be set to remain locked until the camera is turned off (p. 48).

CF If desired, exposure can be set together with focus (p. 47).

<Subjects Especially Liable to Focusing Errors>

The camera's automatic focus mechanism may focus incorrectly, or fail to focus at all, on the following kinds of subjects. In such cases, use the focus lock function to lock the focus on another object that is located at the same distance from the camera as the desired subject, then move the camera to compose the subject as desired and make the photograph.

- Subjects with low light or low contrast.
- Subjects composed of repetitive patterns.
- Dark subjects.
- Subjects composed of horizontal lines.
- Extremely bright or reflective subjects.
- Subjects in which a strong light source is located in or nearby the focus frame, or when the sun or other strong light source is in the picture frame.
- Compositions where two objects located at extremely different distances are both inside the focus frame.
- Subjects moving at high speed.

Photographic Technique

1. Programmed Automatic Mode

In this mode, the camera automatically measures the brightness of the subject and selects the optimum exposure from a preset combination of shutter speeds and apertures. This mode provides best results for snapshots.

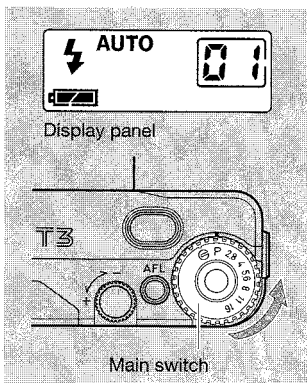

1 Turn the main switch from "☉" to "P".

The camera power turns on and the programmed auto mode is selected.

2 Press the shutter release button to make the photograph.

<Programmed Automatic Exposure Control Table>

The available combinations of shutter speeds and apertures preset by the programmed auto mode are shown in this table.

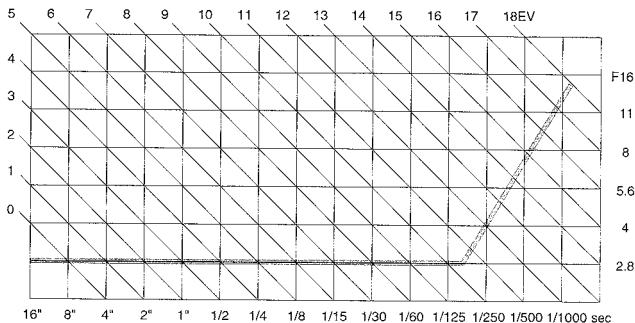

2. Aperture-Priority Automatic Mode

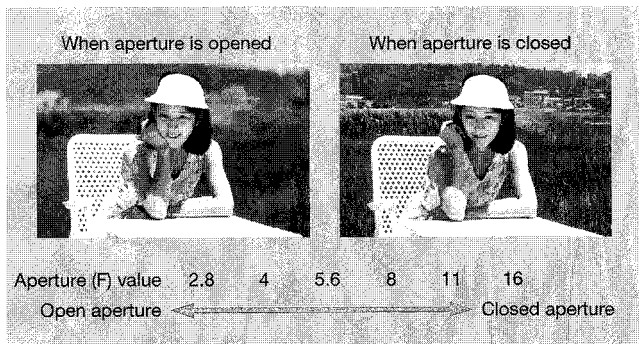

In general, when a lens is focused on any given subject, not only the subject itself, but a certain area in front of and behind the subject will also be in focus. That area is called “depth of field” (see p. 21).

The depth-of-field becomes deeper as the lens aperture is closed, and becomes shallower as the aperture is opened.

This characteristics can be used for photos in which both subject and background are in focus, or one can focus attention on the main subject and blur the background. Select the aperture value in accordance with the needs of your photographic composition.

When using the aperture-priority mode, the lens aperture is set manually; the camera measures the light on the subject and automatically sets the correct shutter speed.

- The viewfinder display will show the shutter speed automatically set by the camera in response to the user-selected aperture.

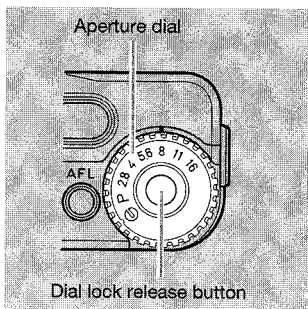

1 While holding the dial lock release button depressed, rotate the aperture dial to set the aperture as desired.

2 Press the shutter release button to make the photograph.

<Aperture-priority Mode Exposure Control Table>

The available combinations of shutter speeds and apertures set in the aperture-priority mode are shown in this table.

	5	6	7	8	9	10	11	12	13	14	15	16	17	18EV	
4															F16
3															11
2															8
1															5.6
0															4
															2.8
	16"	8"	4"	2"	1"	1/2	1/4	1/8	1/15	1/30	1/60	1/125	1/250	1/500	1/1000 sec

* If the available light on the subject is too bright for the pre-programmed automatic-linkage range, the program will automatically shift to get a correct exposure.

● When shooting dark interiors, night scenes, or occasions where flash is required, it is recommended to set the camera to "P", or else set the aperture to F2.8.

3. Exposure Compensation

Exposure compensation is used when there is a great difference in brightness between subject and background or for deliberate over- or underexposure.

Exposure compensation can be set in 1/3 EV steps, in the range of +2EV to -2EV. When exposure compensation has been set, the “±” indicator appears in the viewfinder.

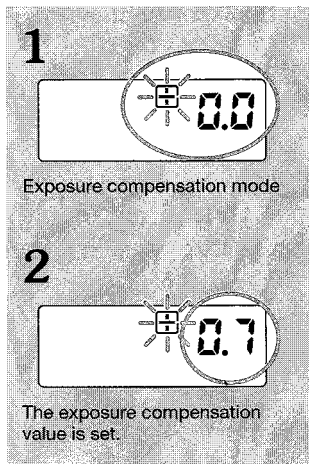

1 With camera ON, press the mode button once so exposure compensation mode appears on the display panel.

2 Turn the mode dial to select the desired exposure compensation value.

3 Press the shutter release button to make the photograph.

The exposure compensation mode is canceled after each photograph is taken.

- To cancel an exposure compensation setting without taking a photograph, repeat steps 1-2, but set the dial to “0.0”
- Eight seconds after setting an exposure compensation value, the display panel will return to its normal mode, with the addition of the “±” or “☐” indicator.

CF It is possible to keep the exposure compensation setting for more than one shot (p. 47).

CF It is also possible to change exposure compensation to 1/2 EV steps instead of 1/3 steps if desired. (p. 47).

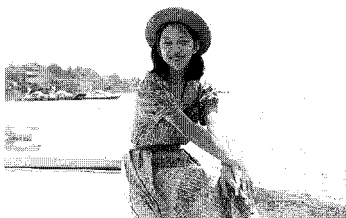

With + exposure compensation



Without exposure compensation

With backlit scenes...

Compensate in range +0.3 EV to +2 EV

When taking backlit portraits against a bright sky or the sea, etc, where the greater part of your picture is occupied by a bright background, your subject will be underexposed and turn out dark like a silhouette. In such cases, compensate exposure in the range of +0.3 EV to +2 EV, to increase exposure.



With - exposure compensation

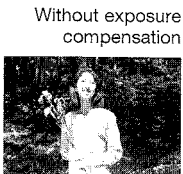

Without exposure compensation

When the background is dark...

Compensate in the range of -0.3 EV to -2 EV

If you are shooting a spotlighted subject on a stage where a dark background dominates the scene, the main subject will be overexposed and appear washed out. In such a case compensate exposure in the range of -0.3 EV to -2 EV to reduce exposure.

4. Selftimer Photography



1

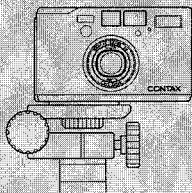

2



Selftimer indicator

3



The selftimer function can be operated with a delay of either 10 sec or 2 sec. When you wish to take a photo with yourself in it, use the 10 sec delay. When using a tripod in a dark location and long exposure times, the 2 sec delay will help prevent camera shake when releasing the shutter manually.

1 Mount camera securely on tripod.

2 With camera power turned on, press the mode button twice, so that the selftimer indicator appears in the display.

3 Use the mode dial to select either "10" or "02."

When the mode dial is rotated, the delay time changes as follows:

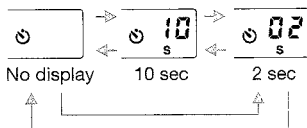

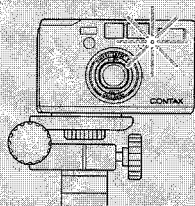
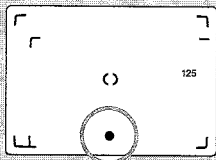
4

4 Depress the shutter release button halfway and confirm that the focus indicator is lighted, then press the shutter fully to activate the selftimer.

5 The selftimer starts and 10 (or 2) sec later the shutter trips.

The selftimer function is automatically canceled after a photograph is taken.

- To cancel the selftimer function after it has started, either press the mode button or turn the camera OFF.
- During operation of the selftimer, the exposure counter shows the remaining time in seconds before the shutter trips. The selftimer LED blinks in the viewfinder.
- Exposure and focus are locked when the selftimer starts.
- If the shutter release button is pressed again after the selftimer has started, the exposure counter is reset and the selftimer starts again.
- To cancel the selftimer set the mode button to "No Display".
- The selftimer operation cannot be started while the flash is charging.

5. Long-Time Exposure

This exposure mode allows time exposures of from 1 to 180 sec, thus making it effective for taking photos of fireworks, starry skies, or skylines at night.

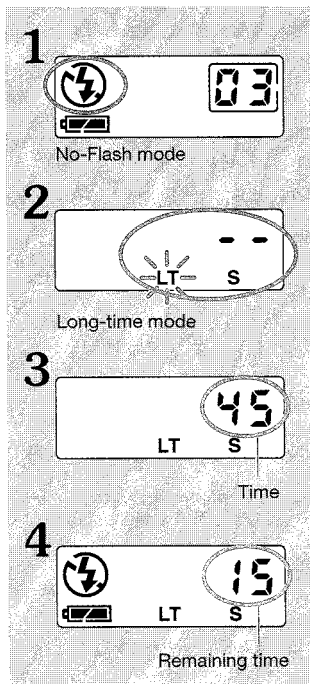

<Available time> (unit: seconds)

01, 1.5, 02, 03, 04, 06, 08, 10, 15, 20, 30, 45, 60, 90, 120, 180

1 With the camera ON, set the flash mode to “”.

- If you wish to use long-time exposure together with flash, select a mode in which the flash will be fired. This will set the camera for “slow-synchro.”

2 Press the mode button **3** times so that the LT indicator appears in the display.

3 Turn the mode dial to select the time.

4 Press the shutter release button to make the photograph.

- During exposure the display panel will show the remaining time until the exposure is completed.

- When exposure is complete, the long-time mode is automatically canceled.
- Reset the flash mode setting to the desired mode.

- The long-time mode does not provide automatic exposure control.
- Use the aperture dial to set the desired aperture for the exposure. Setting the dial to "P" will result in a wide-open (F2.8) aperture.
- To cancel the long-time mode after setting but before you have operated the shutter, follow steps 2-3 to set shutter time to "--".
- 8 sec after setting the shutter speed, the display will return to its normal appearance, with the addition of the "LT" indicator.
- Always use a tripod in this mode to prevent camera shake.
- Using the long-time mode together with the selftimer function will help prevent camera shake caused by pressing the shutter release button.

6. Manual Focus

The camera's focus can be set manually if desired. This is effective when you wish to set the focus to a specific distance, or when taking snapshots using the aperture-priority mode to provide greatest depth of field, or when you wish to be prepared for quick shots without waiting for the camera's auto-focus mechanism to operate.*

* In this mode, the lens is fixed at its extended focusing position, thus reducing the time required for operation of the shutter after pressing the shutter release button.

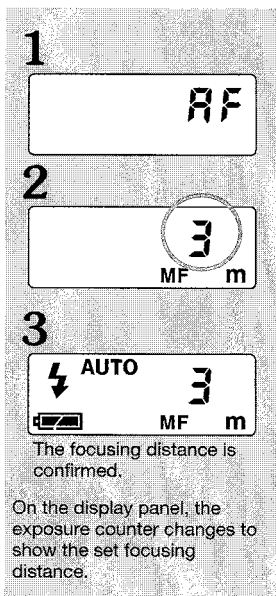

<Available Distances> (unit: meters)

0.4, 0.5, 0.6, 0.7, 0.8, 0.9, 1, 1.1, 1.3, 1.5, 2, 3, 5, 10, ∞F

1 With camera power ON, press the mode button 4 times so that the focus set mode appears in the display panel.

The display panel will show "AF" or "MF"

2 Rotate the mode dial to select the desired focusing distance (in meters).

3 Press the mode button to confirm the focusing distance and extend the lens to the corresponding focusing position.

Once the focusing distance is confirmed, the camera will remain set to the same focusing distance for all subsequent exposures, as long as the power remains turned on.

- The focusing distance is set by depressing the shutter release button halfway, or by waiting for eight or more seconds.
- During manual focusing, the "●" indicator is blinking (1 time/sec) in the viewfinder.

4 Compose the picture and press the shutter release button.

To quickly return to AF mode, press the "AFL" button.

- Set the focus distance referring to the accompanying depth-of-field table (p. 46). For example, when the aperture is set to F8 at a distance of 5 meters, focus will be sharp within a range of 2.44 to ∞ meters (depth-of-field).
- The exposure counter is displayed for about 2 sec after the film has been advanced, then returns to showing the selected focusing distance. The exposure counter also returns when the camera is turned off.

While manual focus is set, the lens remains extended at its set focusing position. Take care not to hold the camera by its lens, or to allow it to strike other objects, which might alter the focus or damage the camera. After setting the focus, if the camera is not used for 10 minutes, the lens will automatically retract in order to prevent damage. The lens will return to its focus position when the shutter release button is depressed halfway.

- CF** If desired, the camera can be set to preserve the manual focus mode even when the camera is turned off (p. 48).

Continued on next page

<Depth-of-Field Table> (Unit: Meters)

This is the distance range producing clearly focused images for the combinations of distance and aperture shown.

Aperture (F stop) Focusing distance (m)	F2.8	F8	F16
0.4	0.39 ~ 0.41	0.38 ~ 0.43	0.36 ~ 0.46
0.5	0.49 ~ 0.52	0.46 ~ 0.55	0.43 ~ 0.60
0.6	0.58 ~ 0.62	0.54 ~ 0.67	0.50 ~ 0.77
0.7	0.67 ~ 0.73	0.62 ~ 0.80	0.56 ~ 0.95
0.8	0.76 ~ 0.84	0.70 ~ 0.94	0.62 ~ 1.15
0.9	0.85 ~ 0.96	0.77 ~ 1.09	0.67 ~ 1.38
1.0	0.94 ~ 1.07	0.84 ~ 1.24	0.72 ~ 1.65
1.1	1.02 ~ 1.19	0.91 ~ 1.40	0.77 ~ 1.95
1.3	1.19 ~ 1.43	1.03 ~ 1.76	0.86 ~ 2.74
1.5	1.36 ~ 1.68	1.15 ~ 2.15	0.94 ~ 3.88
2.0	1.75 ~ 2.34	1.42 ~ 3.41	1.11 ~ 11.9
3.0	2.46 ~ 3.85	1.85 ~ 8.12	1.34 ~ ∞
5.0	3.65 ~ 7.98	2.44 ~ ∞	1.62 ~ ∞
10.0	5.71 ~ 40.8	3.20 ~ ∞	1.92 ~ ∞
∞	13.2 ~ ∞	4.67 ~ ∞	2.35 ~ ∞

7. Custom Functions

This camera is equipped with the seven customizable functions noted in the accompanying table. At time of purchase, functions are set at their factory defaults (contents number standard setting "A"). To change the custom functions, consult the section "Setting Custom Functions" (p. 49).

- When custom functions are set, the camera's functions and operating procedures also change. Be sure to read the descriptions on this page thoroughly in order to understand these functions well.

<List of Custom Functions>

Function No.	Contents No.		Standard Setting		Custom Setting	
	(A)	(B)	(b)	(C)		
CF1: Film leader when film is rewound.	1A: Film is wound completely into cartridge.	1b: Film leader is left exposed after rewind.				
CF2: When lens is extended	2A: Immediately before shutter release	2b: Whenever shutter button is depressed halfway				
CF3: Exposure compensation holding time	3A: 1 frame only	3b: Until camera off	3C: Until setting is canceled			
CF4: Exposure compensation steps	4A: 1/3EV	4b: 1/2EV				
CF5: AFL button function	5A: Focus lock only	5b: Focus lock / AE lock				

Contents No. Function No.	Standard Setting	Custom Setting	
	(A)	(b)	(C)
CF6: Focus lock hold time (AFL button)	6A: 1 frame only	6b: Until camera off	
CF7: Manual focus hold time	7A: Until camera off	7b: Until setting is canceled	
CL: Custom functions reset	Resets all custom functions (1-7) to their default values.		

<Setting Custom Functions>

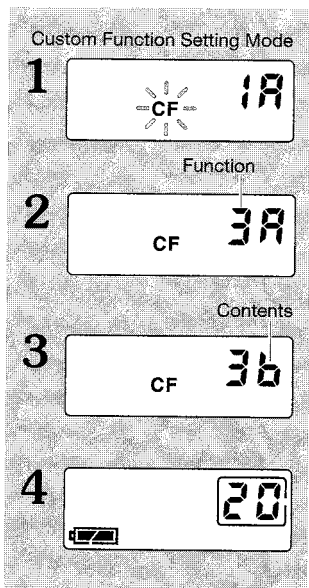

1 With camera turned **OFF**, hold both the flash mode button and mode button depressed simultaneously until the “CF” indicator appears in the display (about 3 sec or more).

2 Rotate the mode dial to select the function number.

3 Press the mode dial to select the function contents.

4 Press the shutter button to set the custom function; the display will return to its normal appearance.

- The custom function can also be set by default by waiting for 8 seconds, or by setting the main switch to “P” while the indicator is blinking.
- To reset the custom functions to default values (CL command) you must set the main switch to “P” to confirm the reset operation.

8. Convenient Techniques Using Custom Functions

The following kinds of photographic techniques can be made more convenient by using the custom functions:

1. To rewind film while leaving the film tip exposed outside the film cartridge:

⇒ Select CF1: 1b

2. To reduce shutter time-lag:

⇒ Select CF2: 2b

This causes the lens to extend fully to focusing position whenever the shutter is depressed halfway, thus reducing the time required to operate the shutter.

3. To use exposure compensation on continuing frames:

⇒ CF3 is used to change the exposure compensation duration

Select CF3: 3A ⇒ Compensation for 1 frame only

Select 3b ⇒ Compensation continues so long as power switch is ON (compensation is automatically canceled when power is turned OFF).

Select 3C ⇒ Compensation continues until manually canceled. (The selected exposure compensation setting continues to be in effect even if the camera power is turned OFF and then ON again.)

4. To change the exposure compensation step:

⇒ CF4 is used to select either 1/3EV or 1/2EV exposure step.

Select CF4: 4A ⇒ Exposure compensation step set to 1/3EV

Select 4b ⇒ Exposure compensation step set to 1/2EV

5. To use AFL button for AE lock:

⇒ Select CF5: 5b

When this function is selected, the AFL button operates to simultaneously set both focus lock and AE lock.

6. To take photographs continuously with focus locked with the AFL button:

⇒ Select CF6: 6b

When this function is selected, focus lock is maintained until camera power is turned OFF.

7. To maintain manual focus until setting is canceled:

⇒ Select CF7: 7b

When this function is selected, the selected manual focusing distance continues in effect until manually canceled. Even if camera power is turned OFF, the selected manual focusing distance will be restored when camera power is next turned ON.

Camera Care and Battery Precautions

- Fingermarks and dirt on the lens and other parts can adversely affect the accuracy of the camera. If they are soiled, clean them lightly with lens cleaning tissue moistened with cleaning fluid. That is enough in most cases. To remove dust, blow off with a blower or dust off with a lens brush.
- To clean the camera body, wipe off with a soft cloth. Never use organic solvents such as benzine and thinner.
- After shooting on a beach or in a dusty place, clean the camera thoroughly. Salt air can cause corrosion, and sand and dust can adversely affect the camera mechanism.
- If the camera is suddenly brought into a warm room from the outside where it is cold, the lens may be clouded. The cloudiness will disappear after a while, but avoid sudden temperature changes if possible.
- This camera contains high-voltage circuits. In case of malfunction, never try to disassemble it by yourself because it is dangerous.
- **If you are going to use the camera for important events such as an overseas trip or wedding ceremony, check to make sure it operates correctly or make test exposures beforehand.**
It is also recommended to bring a spare battery with you.
- The camera is a precision instrument. Do not drop it and avoid intense shock.

<Using the Camera in Cold Weather>

If you are using the camera in cold weather, keep it inside your clothing to warm it up. As the temperature drops, the battery performance will be temporarily reduced and the camera may not operate. However, the battery performance reduced by low temperature returns to normal at ordinary temperature.

Protection circuit of the microcomputer:

This camera incorporates a safety circuit for protecting the built-in microcomputer against strong external electricity.

It occurs, though rarely, that the camera does not operate when this safety circuit is activated. In this case, turn off the main switch, take out the battery, then reload it and turn on the main switch again to use the camera.



<Camera Storage>

- Keep the camera away from heat, moisture and dust and store it in an airy place. Do not store it in a wardrobe drawer containing mothballs or in a laboratory which handles chemicals.
- Do not leave the camera and film for a long time in hot places (on a beach in summer, in a closed car under direct sunlight, etc.) because the camera, film and battery may be adversely affected.

<Battery Precautions>

- Generally, the battery performance is temporarily reduced by low temperature.
If you are taking pictures in cold weather, keep the camera warm by putting it inside your jacket and taking it out only when it is needed. The battery performance reduced by low temperature returns to normal at an ordinary temperature.
- If the (+) and (-) poles of the battery are soiled with sweat or grease, poor contact will result. Wipe both poles clean with a dry cloth before use.
- If you are going on a long trip, bring a spare new battery with you.
- Never put the battery in fire and do not recharge, short, disassemble or heat it because it is dangerous.
- The camera does not operate if the battery is loaded with "+" and "-" ends wrong.
- The 3V lithium battery (CR2) cannot be recharged.
- Keep the battery out of reach of children.

Optional Accessories

1. Contax T3 Data Back

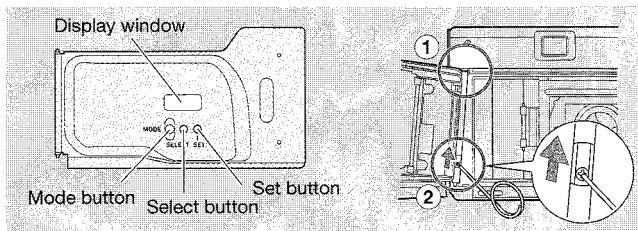

By replacing the standard camera back, the quartz-controlled LCD Data Back is linked with the operations of the camera body. The automatic data function allows imprinting of date and time on photographs.

<Attaching to the Camera>

- ① **Open the standard camera back furnished with the camera; use the provided accessory tool to press up the camera back release pin, thus disconnecting and removing the camera back.**
- ② **Insert the data back's upper hinge pin into the camera's mounting hole, then use the provided accessory tool to press up the camera back release pin while inserting it into the corresponding mounting hole on the camera.**

Data Back Specifications

Type: Built-in quartz clock with LCD display (automatic calendar)
Imprint functions: Year/Month/Day; Day/Hour/Minute; No-imprint;
Month/Day/Year; Day/Month/Year
Imprint method: Automatic shutter-linked imprint
Film speed setting: Automatic
Power source: 3V Lithium battery (CR2025)
Dimensions: 100.5 (W) × 56 (H) × 16 (D) mm
Weight: 45 g (without battery)

* Note: specifications and design are subject to change without notice.

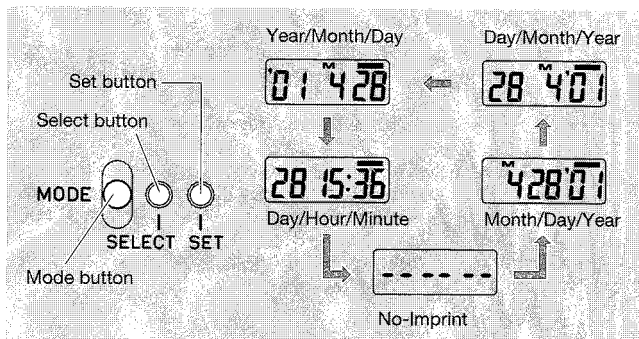

<Date and Time Imprint>

- The Data Back battery is factory installed, so the Data Back can be used immediately.

① Select the imprint mode

Each time the mode button is pressed, the imprint mode changes in the following order: Year/Month/Day → Day/Hour/Minute → ----- (No-Imprint) → Month/Day/Year → Day/Month/Year. Set the imprint format as desired.

② Press the shutter release button normally to take the picture.

- The "—" indicator at the upper right of the display will blink to indicate that the selected display has been imprinted.
- The "M" above the number indicates "Month", and is not imprinted.
- If you do not wish to imprint the date or time, set to -----.
- The imprint will be at the lower right edge of each photograph. The imprint may be difficult to read if the imprint's background area is a bright color like white or yellow.

Continued on next page

<Setting the Date and Time>

To set or correct the date and time proceed as follows:

- ① **Press the mode button to display the data you wish to change.**
- ② **Press the select button so the number to be changed blinks.**
- ③ **Press the set button to set the number to the desired value.**
(The blinking ":" in the time display indicates the second counter. Press the set button together with a radio controlled time signal to set the time accurately.)
- ④ **When setting is complete hold the select button depressed until the number stops blinking.**

<Changing the Data Back Battery>

The Data Back battery is a long-life lithium battery (CR2025) and should last 3-4 years without needing replacement. As the battery becomes depleted, the date and time imprint will become fainter, and the LCD screen will fail to display properly. In this case, change the battery as follows:

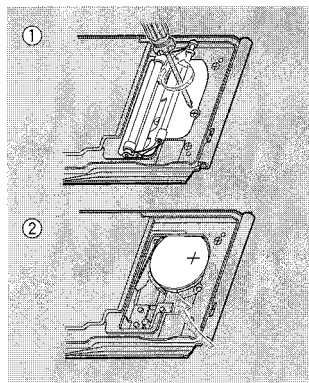

- ① **Open the camera back, remove the screw securing the battery cover, and open the compartment.**
 - ② **Replace the old battery with a new one, taking care to insert with the positive (+) polarity facing outward, then replace the compartment lid and screw down.**
- After replacing the battery, be sure to reset the date and time.

Store Data Back batteries (CR2025) out of the reach of children. In the event a battery is swallowed, seek medical attention immediately.

2. Contax Flash Adapter SA-2

This adapter has been specially designed to allow use of an external flash unit on the Contax T3. When used with the Contax TLA200 flash unit, the TLA200 can be linked electronically to the camera for automatic exposure. When linked in this way, the camera's built-in flash is automatically selected for pictures taken within the range of that flash; when the focusing range is outside the range of the internal flash, the external TLA200 flash will be automatically selected, thus extending the flash capabilities. The adapter also allows connection of an optional L Series cable switch.

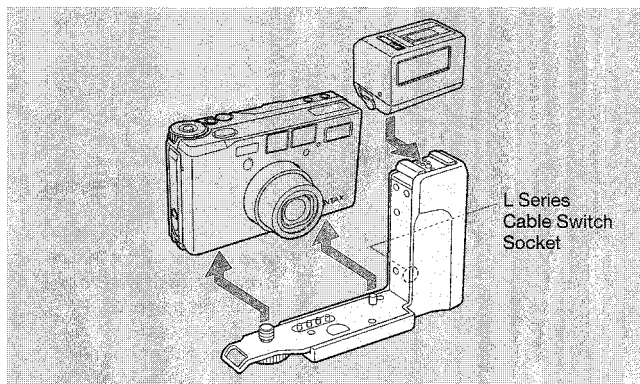

<Installation>

① **Connect the flash adapter SA-2 to the camera body.**

As shown in the illustration, insert the flash adapter's guide pin into the camera's guide hole, and connect the mounting screw securely to the camera's tripod socket.

② **Mount the flash onto the flash adapter.**

Slide the flash into the adapter's mounting bracket securely until it stops.

* Consult the flash unit's operating instructions for directions on removing the flash unit.

Continued on next page

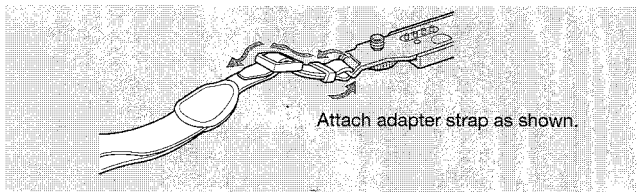

<Using the Flash>

1. Using the TLA200

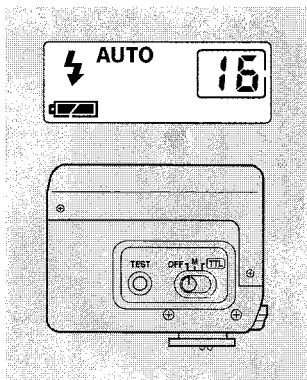

- Set TLA 200 zoom selector to "35" (mm).

- ① **Set the camera's flash mode to "⚡ AUTO".**

Either the internal flash, or the TLA200 will be fired automatically, depending on the brightness of the subject.

- ② **Set the TLA200's power (flash mode selector) to "TTL" and set the camera's aperture in accordance with the flash distances noted on page 59.**

The flash output is automatically controlled to provide optimum exposure at the selected aperture.

- ③ **Press the shutter release button only after confirming that both the cameras' internal flash and the TLA200 are fully recharged.**

Either the camera's internal flash or the TLA200 will be fired automatically, depending on the camera-to-subject distance.

Relationship of Flash Operation and “⚡” Indicator in Viewfinder (Using auto flash, auto red-eye-reduction flash, and night-portrait-flash modes)

Camera-Subject Distance	Viewfinder Display	Built-in Flash	TLA200
Operating range of built-in flash	“⚡” lights	Flash operates	No flash
Outside operating range of internal flash	“⚡” blinks	No flash	Flash operates

- When set to “⚡ AUTO” or “⚡ AUTO 

<T3 Built-in Flash and TLA200 Flash Distance Table> At ISO 100 (figures in parentheses for ISO 400)

Subject Distance m	Built-in flash operating range				TLA200 flash operating range			
	(0.7)	(2)	(4)	(6)	(8)	(10)	(12)	(14)
Exposure/ Aperture	0.35	1	2	3	4	5	6	7
P								
F2.8								
F4								
F5.6								
F8								
F11								
F16								

Continued on next page

2. Using Other Flash Units

Other universal-type auxiliary flash units may be used, but they should be used only at camera-to-subject distances exceeding the range of the camera's built-in flash (overexposure will result if such external flash units are used at closer distances). Consult the operating instructions for the auxiliary flash unit involved regarding usable operating ranges.

- ① **Set the camera's flash mode to "⚡". Both the camera's internal flash, and the attached external flash will be fired.**
 - ② **Set the camera's exposure mode to aperture-priority.**
If the external flash unit is designed for external automatic exposure, set the camera's aperture to the flash-synchro value indicated by the flash. If the external flash unit is designed for manual flash exposure, use the following formula to calculate the aperture required for optimum exposure at the camera-to-subject distance used, and set the aperture accordingly.
$$\text{Subject distance (m)} = \frac{\text{Flash Guide Number (at ISO 100)}}{\text{Aperture value}}$$
 - ③ **Press the shutter release only after confirming that both internal and external flash units are fully charged.**
- If the camera's flash mode is set to "⚡", only the external flash will be fired, and the camera will operate in slow-shutter synchronization mode, producing exposures of up to 16 seconds depending on subject lighting conditions.

3. Other Optional Accessories

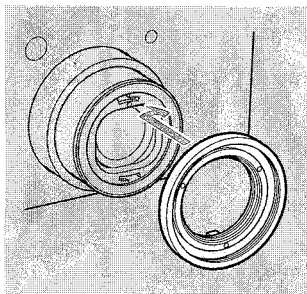

<Contax T3 30.5 Adapter (Bayonet Type)>

This adapter allows Contax 30.5 mm filters and the Contax Tvs II metal lens hood to be used on the T3.

- Use either just the lens hood or the filter, since simultaneous use of filter and hood will cause vignetting.

<Contax 30.5 mm Filters (Threaded Type)>

Available in five types, including P (lens protector), 1A, L39 (UV), A2 (81B), and B2 (82A).

<Contax Tvs II Metal Lens Hood (screw-in Type)>

Screws into the Contax T3 30.5 adapter.

<Contax Tvs Metal Lens Cap K-34 (Snap-on type)>

This metal lens cap is for use with the Contax Metal Lens Hood or filters.

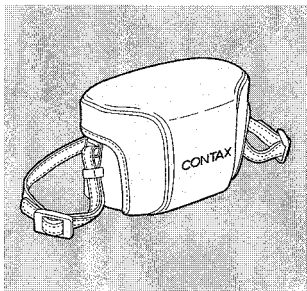

<Contax T3 Semi-Hard Case CC-82>

This quick-use leather case allows convenient storage of the Contax T3 with attached metal hood, Metal Lens Cap K-34, and databack.

Specifications

Type:	35mm fully automatic lens-shutter autofocus camera with built-in flash.
Image size:	24 x 36 mm
Lens:	Carl Zeiss Sonnar T* 35 mm f2.8 (6 elements in 4 groups)
Aperture:	f2.8 - 16
Focusing range:	0.35 m - infinity
Shutter:	Double between-the-lens type
Shutter speeds:	At "P" setting: 16 sec - 1/1200 sec (1/500 sec at open aperture f2.8). LT setting: 1 - 180 sec
Exposure control:	Programmed AE, aperture-priority AE
Automatic exposure range:	EV-1 - EV18 (ISO 100)
Metering:	Two-part external light meter with SPD element.
Exposure compensation:	+/-2 EV (in 1/3 EV step). Can be set to 1/2 EV step in custom functions.
Film speed:	Automatic setting (by DX contacts) in range ISO 25-5000. Non-DX film automatically set for ISO 100.
Focusing:	External passive autofocus with AF assist light and focus lock function. Can be set to manual focus by mode button)
Viewfinder:	Reverse Gailean viewfinder. Magnification ratio 0.5x; Viewfinder coverage: 85% of actual picture area (at 3 meters).
Viewfinder display:	Picture area frame, closeup frame, macro indicator, focus frame, exposure compensation indicator, focus display, flash indicator, shutter speed
LCD monitor:	Flash mode indicator (auto flash, auto red-eye-reduction flash, no flash, fill-in flash, night portrait flash). Operating modes: exposure compensation mode and compensation value; selftimer mode and remaining time; custom function mode and item no; long-time mode and setting time; focus setting mode and set distance; battery power display; exposure counter.
Film loading:	Auto loading, automatic advance to frame no 1
Film transport:	Automatic; single-frame exposure.
Film rewinding:	Auto-return, auto-stop, mid-roll rewind possible.

Exposure counter:	LCD display, automatic-resetting additive type.
Selftimer:	Electronic type with ten sec or two sec delay, cancellable.
Flash:	Built-in; flashmatic and guide-number control. Flash operating distance: see p. 29
Recharging time:	About 3.5 sec (at normal room temperature with new batteries; in accordance with Contax testing standards).
Custom functions:	1) film leader status after rewind; 2) lens focusing position hold time; 3) exposure compensation hold time; 4) exposure compensation step; 5) AFL button function; 6) focus lock hold time (AFL button); 7) manual focus hold time.
Camera back:	Opens via camera back release knob.
Battery:	3V lithium battery (CR2): 1 Capacity: about 12 rolls of 24-exposure film (at normal room temperature with new batteries; in accordance with Contax testing standards), 50 % flash
Data imprint:	Date, time
Dimensions:	105 (W) × 63 (H) × 30.5 (D)
Weight:	230 g (without battery)

* Specifications and design subject to change without notice



KYOCERA CORPORATION

Optical Equipment Group

2-14-9 Tamagawadai, Setagaya-ku, Tokyo 158-8610 Japan

Tel:(03) 3708-4506

<http://www.kyocera.co.jp/>

KYOCERA OPTICS, INC.

2301-200 Cottontail Lane, Somerset, New Jersey 08873, U.S.A.

Tel:(732) 560-0060

KYOCERA OPTICS, INC.

6020 Irwindale Avenue, Unit A-C, Irwindale, California 91706, U.S.A.

Tel:(626) 812-8888

KYOCERA OPTICS, INC.

6200 Dixie Road, Unit 11 Mississauga, Ontario, L5T 2E1, Canada

Tel:(905) 564-9385

YASHICA Kyocera GmbH Eiffestraße 76, D-20537 Hamburg, F.R.Germany

Tel:(040) 25 15 07 0

YASHICA Handelsges. mbH Rustenschacherallee 38, A-1020 Wien, Austria

Tel:(01) 728 09 260

YASHICA AG. Zürcherstraße 73, CH-8800 Thalwil, Switzerland

Tel:(01) 720 34 34

KYOCERA YASHICA (U.K.) Ltd. Unit 7, Suttons Industrial Park, Sutton Park

Avenue, Earley Reading, RG6 1AZ, U.K. Tel:(0118) 935 6300

KYOCERA YASHICA (FRANCE) S.A. ZAC de Paris Nord 11 -13, rue de la perdrix

B.P. 40067 Tremblay en France 95913 Roissy CDG Cedex France Tel: (01) 49 89 38 60

KYOCERA YASHICA DO BRASIL-INDUSTRIA E COMERCIO LTDA.

Av. Bernardino de Campos No. 98, 5-Andar Paraíso,São Paulo CEP: 04004-000,

Brazil Tel: (011) 889-8055

UNIVERSAL OPTICAL INDUSTRIES LTD. 14/FL. Piazza Industrial Building,

133 Hoi Bun Road, Kwun Tong, Kowloon, Hong Kong Tel: 2343 5151