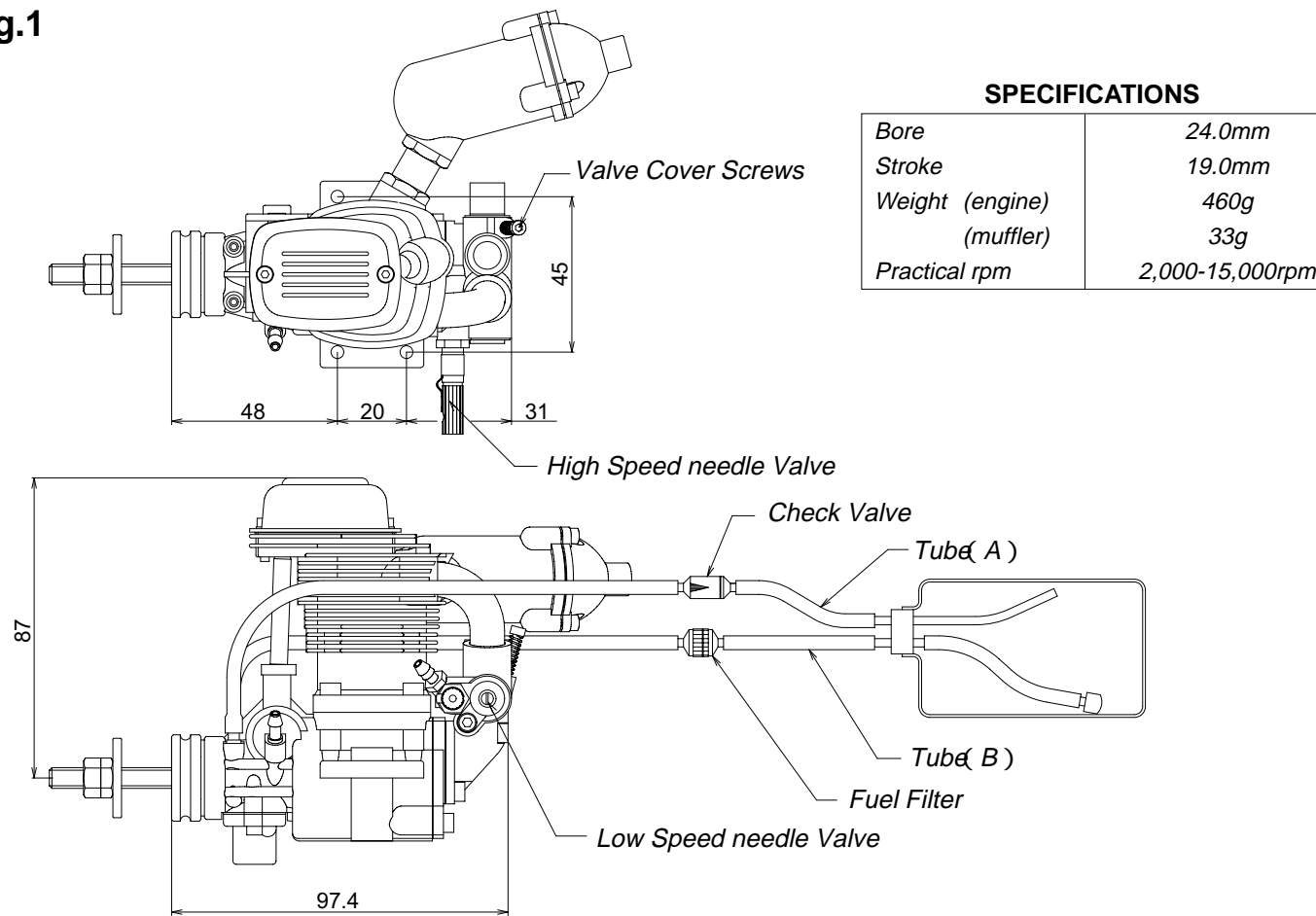

Fig.1



FEATURES

The FZ53 is the most powerful 4 cycle engine of its size and was developed for sport flying as well as power demanding acrobatics.

- Supercharged system
- Fuel injected
- Regulated and pressurized fuel system
- Muffler

The pressurized fuel and injection system makes throttle response superior and is unaffected by tank level.

GLOW PLUG

Select the most appropriate plug from those designed specifically for 4 cycle engines. Glow plug selection greatly affects the maximum engine output and low idle. We recommend the O. S. Type F Plug.

INSTALLATION

1. Connect the engine to the tank as shown in fig.1. Since high pressure is applied to the tank, tighten all connections carefully. Care must be taken to prevent pressure leakage due to under tightening of the check valve or by kinking the fuel lines.
2. Always use a fuel filter. We recommend the YS fuel filter.
3. Match the direction of the check valve arrow fig.1 with the arrow facing to wards the tank.

PROPELLER INSTALLATION

Due to the high torque of the FZ53 engine, we have equipped it with a double lock system for safety.

1. Mount the propeller and tighten the rear nut. Next, tighten the front nut as shown in Fig.1.
2. Select a good quality propeller that will turn in the 9,000 to 11,000 rpm range. We recommend sizes 10x9-10x10, 11x7-11x8, 12x7-12x8.

START UP

1. Remove tube B from the filter: remove tube A from the check valve, then fill the tank. (CAUTION: If tank is filled or under pressure remove tube A first, then tube B. Fuel will eject if tube B is removed while the tank is pressurized.)
2. Open the needle valve 2 1/2 turns from the fully closed position.
3. Open the throttle fully and slowly turn the propeller 10 times. This primes the system by pressurizing the tank and sending fuel to the carburetor.
4. Close the throttle to the idle position and connect the glow plug battery. The engine is now ready for starting.

DO NOT ATTEMPT TO START FULL THROTTLE, AS THIS IS VERY DANGEROUS.

BREAK IN

To maximize engine performance and increase durability, please follow this break-in procedure:

1. Use the same size (or slightly smaller) propeller than you intend to use in flying.
2. Use a good quality fuel which contains 15-30% nitromethane and oil content of 20-24%. Synthetic or castor oil can be used, or a combination of synthetic and castor. Do not use four cycle fuel due to low oil content.
3. The needle valve should be set so that the engine is running at a rich setting. Run the engine approximately 20 minutes with this setting.
4. Mount the engine to the model and fly ten times with this setting. This concludes the break-in procedure, it is advisable to always use a slightly rich setting to keep the moving parts lubricated, even after the break-in period.

HIGH SPEED ADJUSTMENT

1. Adjustment of high speed is done by the carburetor needle valve. When the needle valve is turned clockwise, the mixture is leaner. When it is turned counterclockwise, the mixture is richer. A good starting position for the high speed needle valve is 2 1/2 turns open from the fully closed position.
2. When the engine is started, open the throttle gradually. Next, find the peak position (highest RPM) by adjusting the needle valve. Then the needle valve should be opened approximately 1/8 of a turn from full RPM to achieve best performance. The engine may stop if the throttle is opened to full immediately after starting. Wait until the engine temperature rises and then open the throttle slowly.
3. For flying, it is advisable to use a slightly richer mixture setting. By using a richer mixture, the engine temperature is maintained and RPM stability improves.

LOW SPEED ADJUSTMENT

This engine is equipped with a new low speed needle valve to adjust the mixture from low to mid throttle. This needle valve is located on the side of the throttle barrel opposite the throttle arm (Fig.1).

1. Open the low speed needle to 1 turns from fully closed position.
2. The low speed needle valve should be set after the high speed needle valve has been adjusted. Close the throttle gradually to a idle (approximately 2500rpm). Let it idle for 20 to 30 seconds and then slowly advance the throttle. The adjustment is satisfactory at low speed if transition is smooth at this time.
3. If the engine is running rough on idle, the low speed mixture is rich. If the engine starts to speed up and dies on idle or starts to detonate, when advancing the throttle, the mixture is lean. Turn the low speed needle valve clockwise to richen and counterclockwise for a leaner mixture (note that the direction of the low speed needle valve is opposite the high speed needle valve). Adjustments to the low speed needle valve should be 1/8 to 1/4 of a turn increment at a time to achieve smooth throttle response.

IMPORTANT! The regulator adjusting screw on this engine is factory set. No further adjustments are necessary. If for some reason you have to disassemble the regulator assembly, the regulator adjusting screw should be set flush with the regulator body.

TAPPET CLEARANCE ADJUSTMENT

1. Tappet clearance is factory preset. No adjustment is necessary until after 1 hour of operation (including break-in period).
2. Clearance adjustment should be done when the engine is cool. When the engine temperature is high, clearance is higher due to thermal expansion.
3. The proper clearance setting should be at 0.04-0.1mm. The adjustment is achieved by loosening the locknut (fig.2) and turning the adjusting screw. Tighten the locknut after the adjustment is achieved. Alter the initial 1 hour adjustment, this procedure should be performed a few every 2 hours of use.

Fig.2

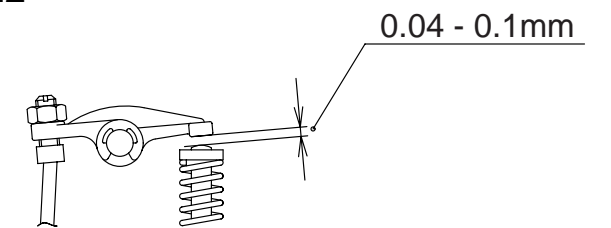

CAM GEAR TIMING ADJUSTMENT

If for some reason you have to disassemble your engine, please follow these important steps on reassembling the cam gear.

1. Remove the carburetor and backplate assembly. Notice the impression made on the crankshaft counterweight. Position it directly straight down or in line with the case outer seam line.
2. When reinstalling the cam gear, the side with a point mark should be facing the opening of the gear box. Note that it should also be mounted with the point mark located towards the top of the engine just below the cam followers.

DIAPHRAGM AND CHECK VALVE DISASSEMBLY

Diaphragm

1. Remove the adjustment screw of the valve, and then remove the inside valve and spring.
2. Clean the inside with alcohol or appropriate cleaner. Reassemble.
3. Screw in the regulator screw until flush with the diaphragm body.

Check valve

1. Open the valve by rotating the body counterclockwise.
2. Reassemble the check valve carefully.

IMPORTANT! Silicone rubber is used in many parts of the YS engine. Use only glow fuel or methanol for cleaning. Gasoline and other volatile solutions will damage the silicone if used.

#	PART#	DESCRIPTION	QTY
1	F5101	Crankcase	1
2	F5102A	Cylinder Head Assembly	1
3	F5102	Cylinder Head & Liner	1
4	F5103	Intake Valve	1
5	F5104	Exhaust Valve	1
6	F5105	Valve Spring Set	2
7	F9106	Spring Retainer Set	2
8	F9107	Valve Spring Retainer Clips	4
10	F5108	Cylinder O-ring	1
11	F5110	Head Screws	4
12	F5111	Valve Cover	1
13	F5112	Valve Cover Gasket	1
14	F5113	Valve Cover Screws	2
15	F5114	Intake Pipe	1
16	F5115	Intake Pipe O-ring	2
17	F5116	Crankshaft	1
18	F5117	Rear Bearing	1
19	F5118	Front Bearing	1
20	F5119	Front Bearing Oil Seal	1
21	F5120	Drive Washer	1
22	F5121	Drive Washer Retainer	1
23	F5122	Propeller Washer	1
24	F5123	Propeller Nut Set	2
25	F5124	Piston	1
26	F5125	Piston Ring	1
27	F5126	Wrist Pin	1
28	F5127	Wrist Pin Retainer	2
29	F5128	Rocker Arm Set	2
30	F1213	Tappet Adjusting Screw Set	2
31	F1214	Tappet Adjusting Lock Nut	2
32	F5131	Rocker Arm Shaft	1
33	F5132	Rocker Arm Screw	1
34	F1217	E Ring Set	2
35	F5134	Cam Gear	1
36	F5135	Cam Gear Cover	1
37	F5136	Cam Gear Cover O-Ring	1
38	F1234	Cam Gear Screws	2
39	F5138	Cam Gear Bearing Set	2
40	F5139	Cam Followers Set	2
41	F5140	Push Rods	2
42	F5141	Push Rod Covers	2
43	F5142	Push Rod Cover O-Ring	4
44	F5143	Con Rod	1
45	F5144A	Back Plate Assembly	1
46	F5144	Back Plate	1
47	F5145	Disc Valve	1
48	F5146	Disc Valve Pin	1
49	F1229	Disc Valve Set Screw	1
50	F5149	Back Plate Gasket	1
51	F5150	Back Plate Screws	2
52	F5151A	Carburetor Assembly	1
53	F5151	Carburetor Body	1
54	F5152	Throttle Barrel	1
55	F5153	Throttle Barrel Seal	1
56	R6124	Throttle Barrel Retainer	1
57	F1260S	Throttle Arm Set	1
58	F1258	Throttle Stop Screw	1
59	F1259	Throttle Stop Spring	1
60	F5158S	Needle Valve Assembly	1
61	F5158	Needle Valve	1
62	F1546	Needle Valve O-ring	1
63	F1555	Needle Soket	1
64	F1256	Needle Soket O-ring	2
65	F1557	Needle Valve Detent	1
66	F5163	Fuel Nipple	1
67	F5186	Low Speed Needle Valve	1
68	F5187	Low Speed Needle Valve O-Ring	1
69	F5164	Carburetor Gasket	1
70	F5165	Carburetor Screws	1
71	F5166A	Regulator Assembly	4
72	F5166	Regulator Body	1
73	F1245	Regulator Adjusting Screw	1
74	F1246	Regulator Adjusting Screw O-ring	1
75	F5169	Diaphragm	1
76	R6138	Regulator Plunger	1
77	F5171	Plunger Spring	1
78	F5172	Regulator Screw Set	2
79	F5173S	Muffler Set	1
80	F5173A	Muffler Assembly	1
81	F5174	Exhaust Pipe	1
82	F5175	Rock Nuts	2
83	F5180	Gasket Set	3
84	F5181	O-Ring Set	11

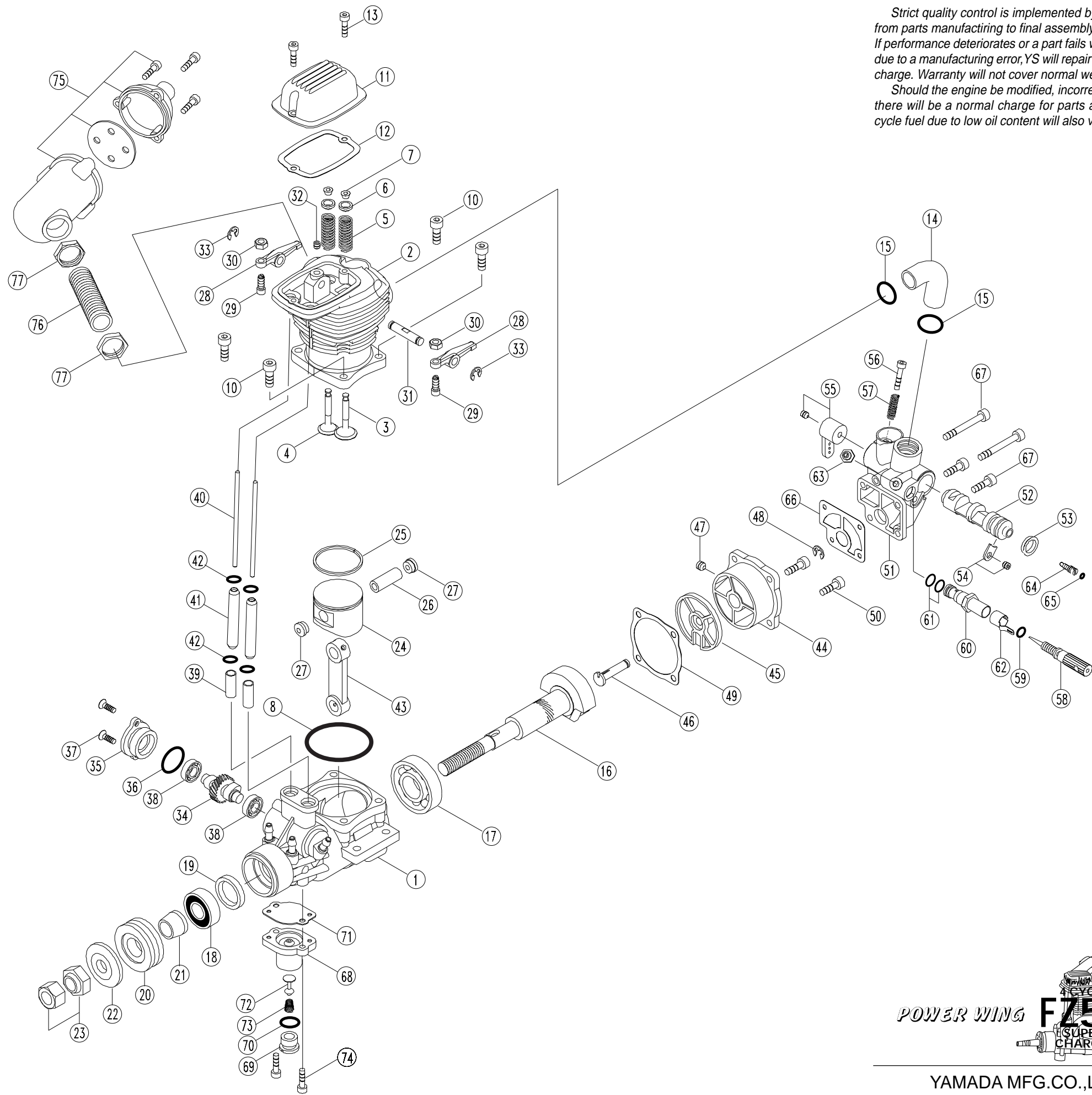

WARRANTY

Strict quality control is implemented by our factory in all phases, from parts manufacturing to final assembly. If performance deteriorates or a part fails within one year of purchase due to a manufacturing error, YS will repair or replace the engine at no charge. Warranty will not cover normal wear.

Should the engine be modified, incorrectly assembled or abused, there will be a normal charge for parts and labor. The use of four cycle fuel due to low oil content will also void warranty.

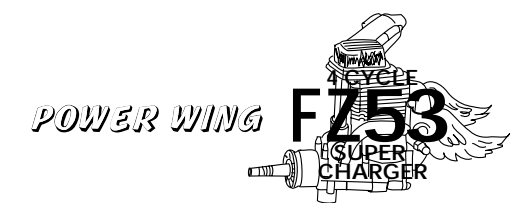

YAMADA MFG.CO.,LTD
67 Tsuchitori Inuyama Aichi 484-0917 JAPAN