

Canon FAXPHONE L80

***Canon FAXPHONE L80
User's Guide***

Product Type and Model

FAXPHONE L80: Facsimile Transceiver, Model H12250

Copyright

This User's Guide is copyrighted by Canon U.S.A., Inc. with all rights reserved. Under the copyright laws, this User's Guide may not be reproduced in any form, in whole or part, without prior written consent of Canon U.S.A.

© 2003 Canon U.S.A., Inc.

Disclaimer

Canon U.S.A., Inc. has reviewed this User's Guide thoroughly in order to make it an easy to use guide for your Canon FAXPHONE L80 system. All statements, technical information, and recommendations in this guide and in any guides or related documents are believed reliable, but the accuracy and completeness thereof are not guaranteed or warranted, and they are not intended to be, nor should they be understood to be, representations or warranties concerning the products described.

Your FAXPHONE L80 has been sold to you subject to the limited warranties set forth in the warranty cards. Further, Canon U.S.A. reserves the right to make changes in the specifications of the products described in this guide at any time without notice and without obligation to notify any person of such changes.

Trademarks

Canon and FAXPHONE are registered trademarks, and UHQ is a trademark of Canon Inc.

All other product and brand names are registered trademarks, trademarks or service marks of their respective owners.



As an ENERGY STAR® Partner, Canon U.S.A. has determined that the FAXPHONE L80 meets the ENERGY STAR® guidelines for energy efficiency.



Super G3 is a phrase used to describe the new generation of fax machines that use ITU-T V.34 standard 33.6 Kbps* modems. Super G3 High Speed Fax machines allow transmission time of approximately three seconds* per page which results in reduced telephone line charges.

* Approximately three seconds per page document transmission time based on ITU-T No. 1 Chart, standard mode, at 33.6 Kbps modem speed. The Public Switched Telephone Network (PSTN) currently supports 28.8 Kbps modem speeds or lower, depending on telephone line conditions.

Users in the U.S.A.

Pre-Installation Requirements for Canon Facsimile Equipment

A. Location

Supply a suitable table, cabinet, or desk. See page 2-2 for the machine's dimensions, and page A-2 for the machine's weight.

B. Order Information

1. Only a single line, touch-tone or rotary telephone set is to be used.
2. Order an RJ11-C modular jack (USOC code), which should be installed by the telephone company. If the RJ11-C jack is not present, installation cannot occur.
3. Order a normal business line from your telephone company's business representative. The line should be a regular voice grade line or the equivalent. Use one line per machine.

DDD (DIRECT DISTANCE DIAL) LINE

-or-

IDDD (INTERNATIONAL DIRECT DISTANCE DIAL) LINE IF YOU
COMMUNICATE OVERSEAS



Note

Canon recommends an individual line following industry standards, e.g. the 2500 (Touch Tone) or 500 (Rotary/Pulse Dial) telephones. A dedicated extension off a PBX machine without "Call Waiting" can be used with your FAXPHONE L80. Key telephone systems are not recommended because they send non-standard signals to individual telephones for ringing and special codes, which may cause a fax error.

C. Power Requirements

This equipment should be connected to a standard 120-volt AC, three-wire grounded outlet only. Do not connect this machine to an outlet or power line shared with other appliances that cause "electrical noise." Air conditioners, electric typewriters, copiers, and machines of this sort generate electrical noise which often interferes with communications equipment and the sending and receiving of documents.

Connection of the Equipment

This equipment complies with Part 68 of the FCC rules and the requirements adopted by the ACTA. On the rear panel of this equipment is a label that contains, among other information, a product identifier in the format US:AAAEQ##TXXXX. If requested, this number must be provided to the telephone company.

An FCC compliant telephone cord and modular jack are provided with this equipment. This equipment is designed to be connected to the telephone network or premises wiring using a compatible modular jack which is Part 68 compliant. See Installation instructions for details.

The Ringer Equivalence Number (REN) is used to determine the number of devices that may be connected to a telephone line. Excessive RENs on a telephone line may result in the devices not ringing in response to an incoming call. In most but not all areas, the sum of RENs should not exceed five (5.0). To be certain of the number of devices that may be connected to a line, as determined by the total RENs, contact the local telephone company. The REN for this product is part of the product identifier that has the format US:AAAEQ##TXXXX. The digits represented by ## are the REN without a decimal point (e.g., 03 is a REN of 0.3).

This equipment may not be used on coin service provided by the telephone company.

Connection to party lines is subjected to state tariffs.

In Case of Equipment Malfunction

Should any malfunction occur which cannot be corrected by the procedures described in this guide, disconnect the equipment from the telephone line and unplug the power cord. The telephone line should not be reconnected or the power cord plugged in until the problem is completely resolved. Users should contact Canon Authorized Service Facilities for servicing of equipment. Information regarding Authorized Service Facility locations can be obtained by calling the Canon Customer Care Center. (1-800-828-4040)

Rights of the Telephone Company

Should the equipment cause harm to the telephone network, the telephone company may temporarily disconnect service. The telephone company also retains the right to make changes in facilities and services which may affect the operation of this equipment. When such changes are necessary, the telephone company is required to give adequate prior notice to the user.

FCC Notice

This device complies with Part 15 of the FCC Rules. Operation is subject to the following two conditions:

- (1) This device may not cause harmful interference, and
- (2) this device must accept an interference received, including interference that may cause undesired operation.



Note

This equipment has been tested and found to comply with the limits for a class B digital device, pursuant to Part 15 of the FCC Rules. These limits are designed to provide reasonable protection against harmful interference in a residential installation. This equipment generates, uses and can radiate radio frequency energy and, if not installed and used in accordance with the instructions, may cause harmful interference to radio communications. However, there is no guarantee that interference will not occur in a particular installation. If this equipment does cause harmful interference to radio or

television reception, which can be determined by turning the equipment off and on, the user is encouraged to try to correct the interference by one or more of the following measures:

- Reorient or relocate the receiving antenna.
- Increase the separation between the equipment and receiver.
- Connect the equipment into an outlet on a circuit different from that to which the receiver is connected.
- Consult the dealer or an experienced radio/TV technician for help.

Use of shielded cable is required to comply with class B limits in Subpart B of Part 15 of FCC Rules.

Do not make any changes or modifications to the equipment unless otherwise specified in the User's Guide. If such changes or modifications should be made, you could be required to stop operation of the equipment.

Canon U.S.A. Inc.
One Canon Plaza, Lake Success, NY 11042, U.S.A.
TEL No. 1-516-328-5000

The Telephone Consumer Protection Act of 1991 makes it unlawful for any person to use a computer or other electronic device to send any message via a telephone fax machine unless such message clearly contains in a margin at the top or bottom of each transmitted page or on the first page of the transmission, the date and time it is sent and an identification of the business or other entity, or other individual sending the message and the telephone number of the sending machine or such business, other entity, or individual.

In order to program this information into your FAXPHONE L80, follow the instructions in Chapter 3 of this User's Guide.

Users in Canada

Pre-Installation Requirements for Canon Facsimile Equipment

A. Location

Supply a suitable table, cabinet, or desk. See page 2-2 for the machine's dimensions, and page A-2 for the machine's weight.

B. Order Information

1. Provide only a single-line to touch-tone or rotary telephone set terminated with a standard 4-pin modular phone plug. (Touch-tone is recommended if available in your area.)
2. Order an CA11A modular jack (USOC code), which should be installed by the telephone company. If the CA11A jack is not present, installation cannot occur.
3. Order a normal business line from your telephone company's business representative. The line should be a regular voice grade line or equivalent. Use one line per machine.

DDD (DIRECT DISTANCE DIAL) LINE

-or-

IDDD (INTERNATIONAL DIRECT DISTANCE DIAL) LINE IF YOU COMMUNICATE OVERSEAS



Note

Canon recommends an individual line following industry standards [e.g., the 2500 (touch tone) or 500 (rotary/pulse dial) telephones]. A dedicated extension off a PBX machine without "Camp On" signals is also permissible with your FAXPHONE L80. Key telephone systems are not recommended because they send non-standard signals to individual telephones for ringing and special codes, which may cause a fax error.

C. Power Requirements

The power outlet should be a three-prong grounded receptacle (Single or Duplex). It should be independent from copiers, heaters, air conditioners or any electric equipment that is thermostatically controlled. The rated value is 120 volts and 15 amperes. The CA11A modular jack should be relatively close to the power outlet to facilitate installation.

Notice

This equipment meets the applicable Industry Canada Terminal Equipment Technical Specifications. This is confirmed by the registration number. The abbreviation, IC, before the registration number signifies that registration was performed based on a Declaration of Conformity indicating that Industry Canada technical specifications were met. It does not imply that Industry Canada approved the equipment.

Cet appareil est conforme aux Spécifications techniques des équipements terminaux de l'Industrie du Canada.

Ceci est confirmé par le numéro d'enregistrement. L'abréviation IC précédant le numéro d'enregistrement signifie que l'enregistrement a été effectué sur la base de la Déclaration de conformité indiquant que le produit est conforme aux spécifications techniques du Canada. Ceci n'implique pas que le produit ait été approuvé par l'industrie du Canada.

Before installing this equipment, users should ensure that it is permissible to be connected to the facilities of the local telecommunications company. The equipment must also be installed using an acceptable method of connection. The customer should be aware that compliance with the above conditions may not prevent degradation of service in some situations.

Repairs to certified equipment should be coordinated by a representative designated by the supplier. Any repairs or alterations made by the user to this equipment, or equipment malfunctions, may give the telecommunications company cause to request the user to disconnect the equipment.

Users should ensure for their own protection that the electrical ground connections of the power utility, telephone lines and internal metallic water pipe system, if present, are connected together. This precaution may be particularly important in rural areas.



Users should not attempt to make such connections themselves, but should contact the appropriate electric inspection authority, or electrician, as appropriate.



This Class B digital apparatus meets all requirements of the Canadian Interference-Causing Equipment Regulations.

Cet appareil numérique de la classe B respecte toutes les exigences du Règlement sur le matériel brouilleur du Canada.

The Ringer Equivalence Number (REN) for this terminal equipment is 1.0. The REN assigned to each terminal equipment provides an indication of the maximum number of terminals allowed to be connected to a telephone interface. The termination on an interface may consist of any combination of devices subject only to the requirement that the sum of the Ringer Equivalence Numbers of all the devices does not exceed five.

Le Nombre d'équivalence Ringer (REN) de cet appareil terminal est 1.0. Le REN attribué à chaque équipement terminal fournit une indication sur le nombre maximum de terminaux pouvant être connectés sur une interface téléphonique. La terminaison sur une interface peut consister en n'importe quelle combinaison d'appareils, à la condition seulement que la somme des Nombres d'équivalence Ringer de tous les appareils ne soit pas supérieure à 5.

CANON CANADA INC.

1-800-263-1121

24 HOURS A DAY, SEVEN DAYS A WEEK

Laser Safety

This machine complies with 21 CFR Chapter 1 Subchapter J as a Class 1 laser product under the U.S. Department of Health and Human Services (DHHS) Radiation Performance Standard according to the Radiation Control for Health and Safety Act of 1968. This means that the machine does not produce hazardous radiation.

Since radiation emitted inside the machine is completely confined within protective housings and external covers, the laser beam cannot escape from the machine during any phase of user operation.

CDRH Regulations

The Center for Devices and Radiological Health (CDRH) of the U.S. Food and Drug Administration implemented regulations for laser products on August 2, 1976. These regulations apply to laser products manufactured from August 1, 1976. Compliance is mandatory for products marketed in the United States.



Use of controls, adjustments, or performance of procedures other than those specified in this User's Guide may result in hazardous radiation exposure.

The label is attached to the laser scanner machine inside the machine and is not in a user access area.

	DANGER - Invisible laser radiation when open. AVOID DIRECT EXPOSURE TO BEAM.
	CAUTION - CLASS 3B, INVISIBLE LASER RADIATION WHEN OPEN. AVOID EXPOSURE TO THE BEAM.
ATTENTION	- RAYONNEMENT LASER INVISIBLE DE CLASSE 3B. EN CAS D'OUVERTURE ÉVITEZ L'EXPOSITION AU FAISCEAU.
VORSICHT	- UNSICHTBARE LASERSTRAHLUNG KLASSE 3B. WENN ABDECKUNG GEOFFNET, NICHT DEM STRAHL AUSSETZEN.
PRECAUCIÓN	- RADIACIÓN LASER INVISIBLE DE CLASE 3B PRESENTE AL ABRIR. EVITE LA EXPOSICIÓN AL HAZ.
VARNING	- KLASS 3B OSYNLIG LASERSTRÅLNING NÄR DENNA DEL ÄR ÖPPNAD. STRÅLEN ÄR FARLIG.
VAROITUS	- LUOKAN 3B NÄKYMÄTTÖMÄLLE LASER-SÄTEILYÄ AVATTUNA. VÄLTÄ ALTISTUMISTA SÄTEELLE.
주의	- 열리면 등급 3B 비가시 레이저 방사선이 방출됩니다. 광선에 노출을 피하십시오.
注意	- ここを開くとクラス3B不可視レーザー放射が出ます。 ビームに身をさらさないこと。
	RU5-8126

Contents

Chapter 1: Introduction

Welcome	1-2
Main Features of the FAXPHONE	1-3
Using Your Documentation	1-4
How to Use This Guide.....	1-4
Type Conventions Used in This Guide	1-5
Customer Support.....	1-6
Important Safety Instructions	1-7

Chapter 2: Setting Up

Choosing a Location for the FAXPHONE	2-2
Dimensions	2-2
Unpacking the FAXPHONE	2-3
Do You Have Everything?.....	2-3
Removing Shipping Materials.....	2-5
Assembling the FAXPHONE.....	2-6
Attaching the Handset to Your Machine	2-7
Making Connections	2-8
Connecting the Telephone Line Cord and External Devices.....	2-8
Connecting the Power Cord	2-9
Connecting the FAXPHONE to Your PC	2-10
Main Components of the FAXPHONE	2-11
Operation Panel.....	2-12
Special Function Buttons.....	2-12
LCD (Standby Mode).....	2-12
Installing the Cartridge.....	2-13
Loading Paper	2-16
Testing the FAXPHONE.....	2-18

Chapter 3: Registering Information

Guidelines for Entering Numbers, Letters, and Symbols	3-2
Correcting a Mistake.....	3-4
Registering Required Sender Information	3-5
What is Sender Information?	3-5
Registering Your Sender Information.....	3-6
Setting the Telephone Line Type	3-8
Setting the Daylight Saving Time.....	3-9

Chapter 4: Document Handling

Document Requirements	4-2
Scanned Area of a Document	4-2
Loading Documents.....	4-3
Adding Pages to the Document in the ADF.....	4-4

Chapter 5: Print Media Handling

Print Media Requirements	5-2
Printable Areas	5-3
Selecting and Loading Print Media.....	5-4
Paper	5-4
Envelopes	5-4
Transparencies	5-6
Selecting Face-Up or Face-Down Delivery	5-7
Changing the Paper Size Setting	5-9
Adjusting the Toner Saver Setting	5-11

Chapter 6: Speed Dialing

What is Speed Dialing?	6-2
Speed Dialing Methods	6-2
Registering One-Touch Speed Dialing	6-3
Registering Coded Speed Dialing	6-8
Registering Group Dialing.....	6-13
Using Speed Dialing	6-16
Sending a Document With Speed Dialing	6-16
Making a Telephone Call With Speed Dialing	6-17
Dialing with the Directory.....	6-18
Printing Speed Dialing Lists.....	6-19

Chapter 7: Sending Faxes

Preparing to Send a Fax.....	7-2
Documents You Can Fax.....	7-2
Setting the Scanning Resolution	7-2
Setting the Scanning Contrast.....	7-3
Dialing Methods	7-4
Sending Methods.....	7-5
Memory Sending.....	7-5
Manual Sending Via the Handset.....	7-6
Canceling Sending.....	7-8
Redialing When the Line is Busy.....	7-9
Manual Redialing	7-9
Canceling Manual Redialing.....	7-9
Automatic Redialing.....	7-9
What is Automatic Redialing?.....	7-9
Canceling Automatic Redialing.....	7-9
Setting the Options for Automatic Redialing.....	7-10
Sending the Same Document to Several Fax Numbers (Sequential Broadcasting)	7-12
Delayed Sending	7-15
Scanning a Document into Memory for Delayed Sending	7-15

Printing a Document Set for Delayed Sending.....	7-17
Deleting a Document Set for Delayed Sending.....	7-18

Chapter 8: Receiving Faxes

Receiving Methods	8-2
Receiving Both Faxes and Telephone Calls Automatically: Fax/Tel Mode.....	8-3
Setting Fax/Tel Mode.....	8-3
Setting the Options for Fax/Tel Mode.....	8-4
Receiving Faxes Manually: MANUAL MODE.....	8-6
Setting MANUAL MODE.....	8-6
Receiving a Fax Manually	8-6
Receiving Faxes Automatically: FAX ONLY MODE	8-8
Setting FAX ONLY MODE	8-8
Receiving With an Answering Machine: ANS.MACHINE MODE	8-9
Setting ANS.MACHINE MODE.....	8-9
Using the FAXPHONE With an Answering Machine.....	8-9
Receiving With the Distinctive Ring Pattern Detection Feature: DRPD.....	8-10
Setting DRPD	8-10
Receiving While Performing Other Tasks.....	8-12
Receiving Faxes in Memory When a Problem Occurs.....	8-12
Canceling Receiving	8-12

Chapter 9: Special Features

Special Dialing.....	9-2
Dialing Through a Switchboard	9-2
Entering Pauses in a Fax/Telephone Number.....	9-2
Switching Temporarily to Tone Dialing.....	9-3
Documents Stored in Memory	9-4
Printing a List of Documents Stored in Memory.....	9-4
Printing a Document Stored in Memory	9-5
Sending a Document Stored in Memory	9-6
Deleting a Document Stored in Memory	9-8
Polling	9-9
What is Polling?.....	9-9
Polling Receiving	9-9
Polling Another Fax Machine.....	9-9
Canceling Polling Receiving	9-11
Polling Sending.....	9-12
Setting Up the Polling Box.....	9-12
Scanning a Document into the Polling Box.....	9-15
Changing or Deleting the Polling Box Settings	9-15
Restricting Reception.....	9-17

Chapter 10: Copying

Documents You Can Copy	10-2
Making Copies	10-2

Chapter 11: Reports and Lists

Summary of Reports and Lists	11-2
ACTIVITY REPORT	11-3
TX (Transmission) REPORT	11-4
MULTI TX/RX (Transaction) REPORT	11-5
RX (Reception) REPORT	11-5

Chapter 12: Maintenance

Periodic Cleaning	12-2
Cleaning the Machine's Exterior	12-2
Cleaning the Machine's Interior	12-2
Cleaning the Scanner Components	12-5
Replacing the FX-3 Cartridge	12-7

Chapter 13: Troubleshooting

Clearing Jams	13-2
Jams in the ADF	13-2
Paper Jams	13-3
Jams in the Paper Delivery Slots	13-3
Jams Inside the Machine	13-3
LCD Messages	13-8
Paper Feeding Problems	13-13
Printing Problems	13-14
Faxing Problems	13-15
Sending Problems	13-15
Receiving Problems	13-16
Copying Problems	13-18
Telephone Problems	13-19
General Problems	13-19
If You Cannot Solve a Problem	13-20
If a Power Failure Occurs	13-21

Chapter 14: Summary of Settings

Understanding the Menu System	14-2
Printing a List to Check the Current Settings	14-2
Accessing the Menus	14-3
USER SETTINGS Menu	14-4
REPORT SETTINGS Menu	14-5
TX (Transmission) SETTINGS Menu	14-6
RX (Reception) SETTINGS Menu	14-7

PRINTER SETTINGS Menu	14-8
POLLING BOX Menu.....	14-9
SYSTEM SETTINGS Menu	14-10

Appendix: Specifications

General Specifications	A-2
Printer	A-2
Facsimile	A-2
Copier	A-3
Telephone	A-3

Index	I-1
--------------------	-----

Chapter 1

Introduction

This chapter introduces you to the main features of the machine. It also explains how to get the most out of the documentation provided, and gives important safety instructions.

Welcome	1-2
Main Features of the FAXPHONE	1-3
Using Your Documentation	1-4
How to Use This Guide	1-4
Type Conventions Used in This Guide	1-5
Customer Support	1-6
Important Safety Instructions	1-7

Welcome

Thank you for purchasing the Canon FAXPHONE L80 (hereafter referred to as the FAXPHONE or machine).

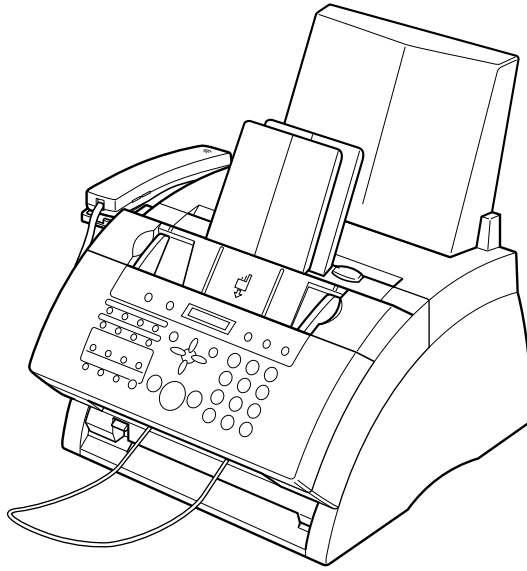

Your machine is a complete multifunction system for your home or small office. It combines the following essential office machines into a single, convenient desktop machine.

- Printer
- Plain Paper Fax Machine
- Copier
- Telephone

With its multitasking ability, your machine enables you to perform a number of operations simultaneously. For example, you can print or make copies at the same time you are sending from memory or receiving a fax into memory.

Main Features of the FAXPHONE

■ Printer Features

- 600 × 600 dpi laser printing for high resolution text and graphics
- Print speed of approximately 6 letter-size pages* per minute
- Easy installation of the cartridge
- Convenient multi-purpose tray for loading a variety of paper and other print media
- Toner saving feature for less toner consumption and a longer cartridge life

■ Plain Paper Fax Features

- Automatic switching between fax and voice calls
- Fast transmission speed with super G3 technology encoding—up to approximately 3 seconds* per page
- 350-page* memory for storing faxes
- Canon's Ultra High Quality (UHQ™) Image Processing System for enhanced definition in faxed photos
- Error Correction Mode (ECM) to reduce transmission errors when sending to or receiving from fax machines with ECM capability
- Automatic dialing and broadcasting—one-touch, coded speed, group, and directory dialing
- Answering machine connection for automatically receiving both messages and faxes
- Automatic reduction of received faxes when paper in the machine does not match transmitted page size
- Special faxing features, such as delayed sending, polling, and reception restriction
- DRPD (Distinctive Ring Pattern Detection) capability (subscription to a DRP service necessary)

■ Copier Features

- Multiple copies—up to 99
- 400 × 300 dpi high-resolution copying (single copies)
- Copy reduction—90%, 80%, or 70%

■ Telephone Features

- Connection for handset, as well as one other external device (extension telephone, answering machine, or data modem)
- One-touch and coded speed dialing for quick and efficient dialing
- Directory dialing

*Based on ITU-T No. 1 Chart, standard mode.

Using Your Documentation

Your machine includes the following four manuals:

- **Set-Up Instructions:** This guide provides a quick reference on how to set up the machine, connect it to your PC, and install the included software.
- **Basic Guide:** After following the instructions in the Set-Up Instructions, we recommend you read this guide to familiarize yourself with the basic operation of all functions of your machine.
- **FAXPHONE L80 User's Guide** (this guide): Refer to this guide (included in the CD-ROM) for instructions on setting up your machine, setting your machine to send and receive, and making copies. There is also information on selecting and loading print media and documents, instructions on machine maintenance, and a troubleshooting section to refer to if you have difficulties operating your machine.
- **Printer Driver Software User's Guide:** Refer to this guide (included in the CD-ROM) for instructions on printing from your PC. Here you will find detailed instructions on installing the printer driver software and operating it, and other relevant information for using your machine as a printer. Refer to the troubleshooting section if you have trouble printing.

How to Use This Guide

To make the best use of this guide, be sure to do the following:

- Read this chapter to learn about your machine's main features, and for guidelines on using the machine safely.
- Carefully follow the instructions in Chapter 2, *Setting Up*, to get your machine unpacked, assembled, and ready for use.
- Read Chapter 3, *Registering Information*, to learn how to enter information in the machine, and how to register the required sender information.
- Refer to Chapter 4, *Document Handling*, for details on the document requirements for your machine and how to load them.
- Refer to Chapter 5, *Print Media Handling*, for details on paper and other print media you can load on your machine, guidelines for selecting them, and other information relating to print media and printing.
- Read Chapter 6, *Speed Dialing*, to learn how to register numbers for speed dialing and how to use speed dialing to send documents.
- Read Chapters 7 through 10 to master the machine's operating procedures, such as sending and receiving faxes, special dialing, and making copies.
- Refer to Chapter 11, *Reports and Lists*, to learn about the reports and lists that can be automatically or manually printed from your machine.
- Look over Chapter 12, *Maintenance*, to become familiar with procedures for cleaning the machine and replacing the cartridge.

- If your machine is not operating properly, use Chapter 13, *Troubleshooting*, to try to fix the problem.
- Refer to Chapter 14, *Summary of Settings*, to learn how to change default settings, and how to customize your machine to your needs.
- Refer to Appendix, *Specifications*, for the machine's technical specifications.

If you still have questions on how to use your machine, please contact the Canon Customer Care Center. They will be happy to answer your questions.



Note You must register your fax number, your name or company name, and the date and time on your machine before using it. This is required by the FCC rules governing the use of fax equipment. For details, see p. 3-5.

Type Conventions Used in This Guide

Please read the list below of symbols, terms, and abbreviations used in this guide.



CAUTION **Cautions tell you how to avoid actions that could injure you or damage your machine. In order to use your machine safely, always observe these cautions.**



Note Notes provide advice on using your machine more effectively, describe operating restrictions, and tell you how to avoid minor difficulties. Reading these is recommended to make the most of your machine and its functions.

(→ p. n-nn)	A number preceded by an arrow and enclosed in parenthesis references a page number (p.) or page numbers (pp.) that contain more information on the topic of the previous sentence.
(→ <i>Software User's Guide</i>)	Refer to the <i>Printer Driver Software User's Guide</i> in the CD-ROM for details on the topic of the previous sentence.
default	A setting that remains in effect unless you change it.
document or fax	The original sheet(s) of paper you send or receive and copy with your machine.
menu	A list of settings from which you select an item to set up or change. A menu has a title which appears in the LCD.
LCD	<i>Liquid Crystal Display</i> . The display on the operation panel that displays messages and settings.

In addition, this guide uses distinctive typefaces to identify buttons and information in the LCD:

- The buttons which you should press appear in this typeface: **Stop/Reset**.
- Information from the LCD appears in this typeface: USER SETTINGS.

Customer Support

Your machine is designed with the latest technology to provide trouble-free operation. The warranty information describes Canon's limited warranty for this product. Be sure to read this warranty information.

If you have a problem with the machine's operation, try to solve it by referring to the information in Chapter 13. If you cannot solve the problem or if you think your machine needs servicing, contact the Canon Customer Care Center.



You must have your sales receipt for warranty service.

Note

Important Safety Instructions

Read these safety instructions thoroughly before using your machine.



Except as specifically described in this guide, do not attempt to service the machine yourself. Never attempt to disassemble the machine: opening and removing its interior covers will expose you to dangerous voltages and other risks. For all service, contact the Canon Customer Care Center.

■ Handling and Maintenance

- Follow all warnings and instructions marked on the machine.
- Do not subject the machine to strong physical shocks or vibrations.
- Always unplug the machine before moving or cleaning it.
- To avoid paper jams, never unplug the power cord, open the front cover, or add or remove paper in the multi-purpose tray while printing.
- When transporting the machine, be sure to remove the cartridge from the machine. Place the cartridge in its original protective bag or wrap it in a thick cloth to prevent exposure to light.
- Always lift the machine as shown below. Never lift it by any of its attachments.

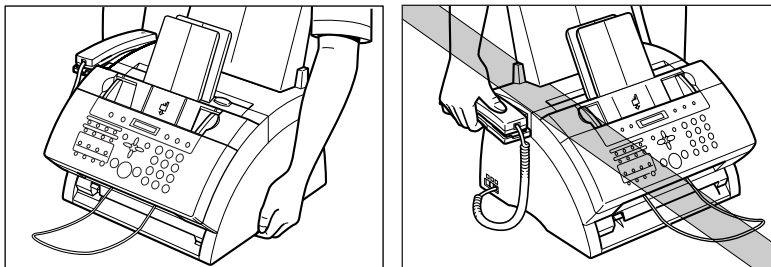

- Do not insert any objects into the slots or openings on the machine since they may touch dangerous voltage points or short out parts. This could result in fire or electric shock.
- Do not allow small objects (such as pins, paper clips, or staples) to fall into the machine. If something does fall into it, unplug the machine immediately and contact the Canon Customer Care Center.
- To avoid spillage in or around the machine, do not eat or drink near it. If you spill liquid or if any substance falls into it, unplug the machine immediately and contact the Canon Customer Care Center.
- Keep the machine clean. Dust accumulation can prevent the machine from operating properly.

- Unplug the machine from the wall outlet and contact the Canon Customer Care Center in any of the following cases:
 - If the power cord or plug is damaged or frayed.
 - If liquid has spilled into the machine.
 - If the machine has been exposed to rain or water.
 - If the machine does not operate normally when you have followed the instructions in this guide. Adjust only those controls that are covered by the instructions in this guide. Improper adjustment of other controls may result in damage and may require extensive work by a qualified technician to restore the product to normal operation.
 - If the machine has been dropped or the cabinet has been damaged.
 - If the machine exhibits a distinct change in performance, indicating a need for servicing.

■ Location

- Place the machine on a flat, stable, vibration-free surface.
- Place the machine in a cool, dry, clean, well-ventilated place.
 - Make sure the area is free from dust.
 - Make sure the location is not affected by extreme temperature changes, and always stays between 50°F and 90.5°F (10°C and 32.5°C).
 - Make sure the area's relative humidity is always between 20% and 80%.
- Keep the machine away from direct sunlight, as this can damage it. If you have to place it near a window, install heavy curtains or blinds.
- Do not use the machine near water. Make sure that no wet or damp objects come into contact with the machine.
- Do not use or store the machine outdoors.
- Do not install the machine near devices that contain magnets or generate magnetic fields, such as speakers.
- If possible, place the machine near an existing telephone line outlet for easy connection of the telephone line cord, and to avoid the expense of installing a new outlet.
- Place the machine near a standard 120 V AC (60 Hz) power outlet.
- Place the machine near the PC you will be connecting it to. Make sure you can reach it easily since you will be using it as a printer, fax machine, and copier.
- To ensure reliable operation of the machine and to protect it from overheating (which can cause it to operate abnormally and create a fire risk), do not block the exhaust vent. Never block or cover any openings on the machine by placing it on a bed, sofa, rug, or other similar surface. Do not place the machine in a closet or built-in installation, or near a radiator or other heat register unless proper ventilation is provided. Leave approximately 4 inches (10 cm) space around all sides of the machine. For the dimensions of the machine, see p. 2-2.

- Do not stack boxes or furniture around the power outlet. Keep the area free so you can reach the outlet quickly. If you notice anything unusual (smoke, strange odors, noises) around the machine, unplug the machine immediately. Contact the Canon Customer Care Center.
- Do not allow anything to rest on the power cord, and do not place the machine where the cord will be walked on. Make sure the cord is not knotted or kinked.

■ Power Supply

- During electrical storms, disconnect the power cord from the power outlet. (Please note that any documents stored in the machine's memory will be deleted when you unplug the machine.)
- Whenever you unplug the machine, wait at least five seconds before plugging it in again.
- Do not plug the machine into an uninterruptible power supply (UPS).
- If dust accumulates around the plug of the power cord when it is connected to a power outlet, unplug the machine and wipe the plug with a clean, dry cloth.



This product emits low level magnetic flux.

If you use a cardiac pacemaker and feel abnormalities, please move away from this product and consult your doctor.

Chapter 2

Setting Up

This chapter explains all the necessary steps to get your machine ready for use. You will find instructions for unpacking, assembling, and connecting your machine, and learn how to install the cartridge and load paper.

Choosing a Location for the FAXPHONE	2-2
Dimensions.....	2-2
Unpacking the FAXPHONE	2-3
Do You Have Everything?.....	2-3
Removing Shipping Materials.....	2-5
Assembling the FAXPHONE	2-6
Attaching the Handset to Your Machine.....	2-7
Making Connections	2-8
Connecting the Telephone Line Cord and External Devices.....	2-8
Connecting the Power Cord.....	2-9
Connecting the FAXPHONE to Your PC.....	2-10
Main Components of the FAXPHONE	2-11
Operation Panel.....	2-12
Special Function Buttons.....	2-12
LCD (Standby Mode).....	2-12
Installing the Cartridge	2-13
Loading Paper	2-16
Testing the FAXPHONE	2-18

Choosing a Location for the FAXPHONE

Before unpacking your machine, be sure to choose a suitable location for it (→ p. 1-8).

Dimensions

Make sure the location you choose provides enough space around the machine for adequate ventilation, and to allow paper to flow freely into and out of the machine. Leave approximately 4 inches (10 cm) space around all sides of the machine. The illustrations below show the dimensions of the machine.

TOP VIEW

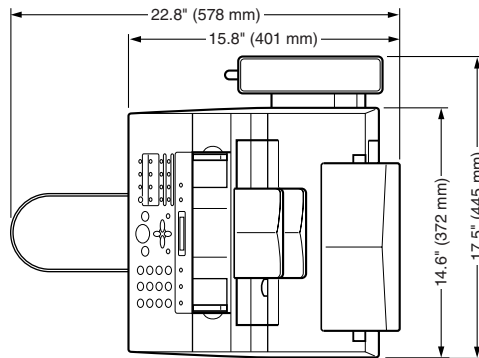

SIDE VIEW

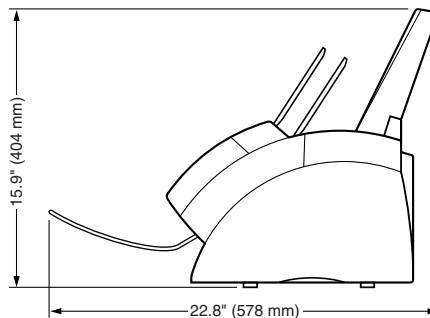

BOTTOM VIEW

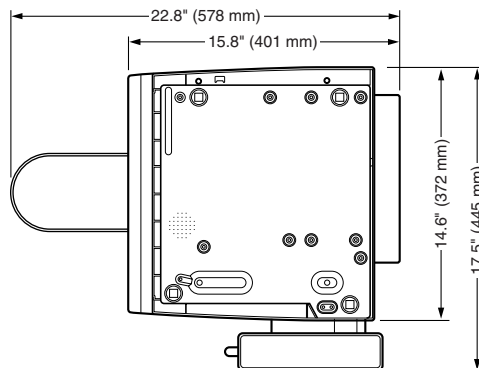

Note

If you need help installing the machine or have any questions about it, please contact the Canon Customer Care Center.

Unpacking the FAXPHONE

Follow the directions below to unpack the machine properly and to make sure you have all its components.



Note

When lifting the machine out of the box or when moving it, lift it from the recessed areas on the sides of the machine. Make sure you hold the machine firmly and level.

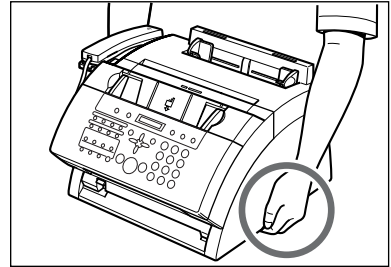

Do You Have Everything?

Carefully remove all items from the box. You should have someone help you hold the box while you lift out the machine and its protective packaging. Save the carton and packaging in case you need to transport the machine in the future.

Make sure you have all the following items:

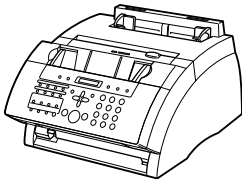

MACHINE

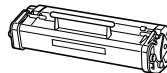

FX-3 S CARTRIDGE



SUPPORT TRAYS

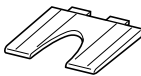

MULTI-PURPOSE TRAY

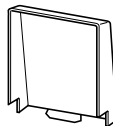

MULTI-PURPOSE TRAY COVER



DOCUMENT SUPPORT

POWER CORD

TELEPHONE LINE CORD

DOCUMENTATIONS and LABELS

SOFTWARE USER'S CD-ROM

REGISTRATION CARD (for USA only)

WARRANTY

FX-3 CARTRIDGE WARRANTY

HANDSET

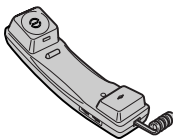

HANDSET CRADLE

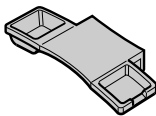

PLUGS WITH PINS (2)

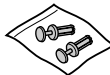

If any items are damaged or missing, notify the Canon Customer Care Center immediately.



Note

- Important! Save your sales receipt for proof of purchase in case your machine requires warranty service.
- If you are connecting your machine to a PC, you will need to purchase a USB cable (→ p. 2-10).

Removing Shipping Materials

Follow this procedure to remove the shipping materials. Keep them in case you need to transport the machine in the future.

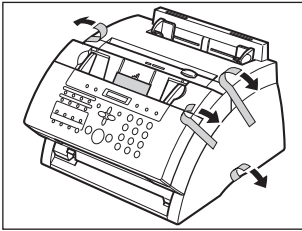

- 1** Remove all shipping tapes from the machine.

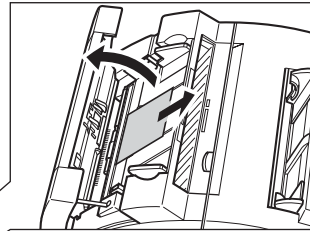
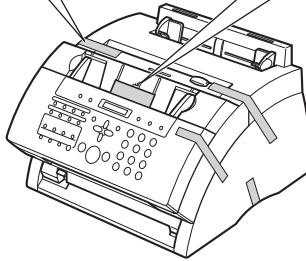

- 2** Use both hands to gently open the operation panel (it only opens partially). Then remove the protective sheet from the ADF. Close the operation panel by pressing it down at the center until it locks into place.



The actual shipping materials may differ in shape, quantity, and position from the ones shown above.

Assembling the FAXPHONE

Follow this procedure to assemble your machine:

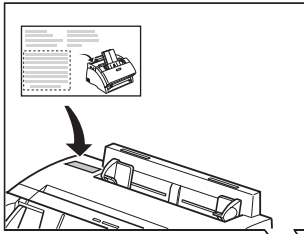

- 1** Attach the paper loading warning label to the left of the multi-purpose tray.

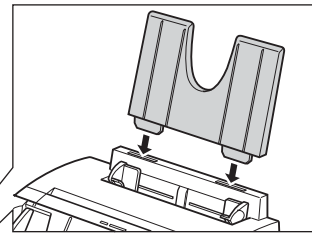

- 2** Insert the tabs of the multi-purpose tray into the slots on the machine.

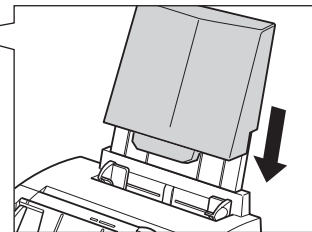

- 3** Slide the multi-purpose tray cover over the multi-purpose tray.

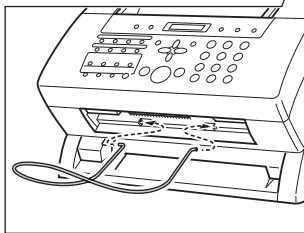

- 4** Insert the ends of the document support into the slots on the machine.

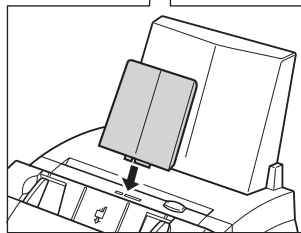

- 5** Insert the tabs of one of the support trays into the corresponding slots above the face-down delivery slot.

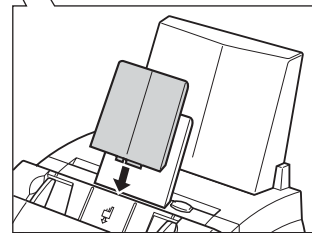

- 6** Insert the tabs of the other support tray into the corresponding slots above the ADF.

Attaching the Handset to Your Machine

Follow this procedure to attach the handset to your machine:

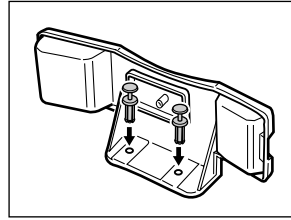
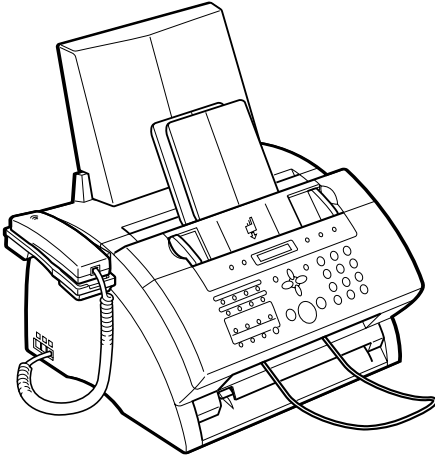

- 1** Insert the plugs with pins into the holes on the handset cradle.
 - Do not push the pins all the way into the plugs at this stage.

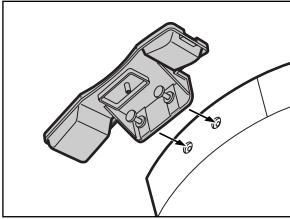

- 2** Insert the plugs (with the handset cradle) into the holes on the left side of the machine.
 - If you have difficulty inserting the plugs, turn the machine so that the left side is facing you. You can now insert the plugs without the machine moving.

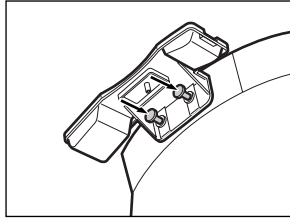

- 3** Carefully push the pins into the plugs.
 - Make sure the pins are pushed in as far as they will go.
 - Make sure you support the machine when inserting the pins.

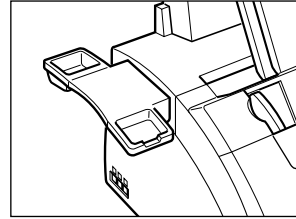

- 4** Place the handset on its cradle and connect the handset cord to the  jack (→ p. 2-8).

Making Connections

Connecting the Telephone Line Cord and External Devices

Your machine has three jacks on the left side for connection of the following:

- Telephone line cord
- Handset
- Extension telephone, answering machine, or data modem (optional)

Be sure to connect any external device before using your machine. Follow this procedure to connect the telephone line cord and external device(s):

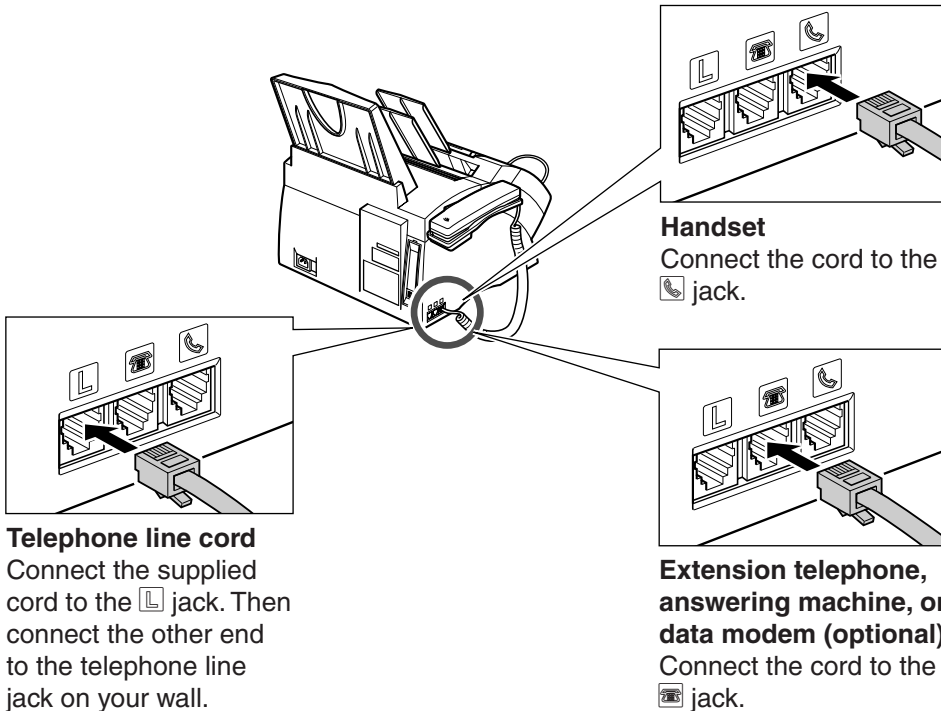

Note

- You must complete all the steps above to receive faxes properly.
- Canon cannot guarantee that all answering machines will be compatible with your machine, due to varying specifications.
- If you have connected an external device to your machine, be sure to set the correct receive mode (→ Chapter 8).
- To connect an extension telephone as well as an answering machine, connect the extension telephone to the answering machine, and then the answering machine to your machine.
- If you use your data modem extensively, you may prefer to have a dedicated telephone line for it.

Connecting the Power Cord

Before connecting the power cord, see *Power Supply*, p. 1-9.

Follow this procedure to connect the power cord:

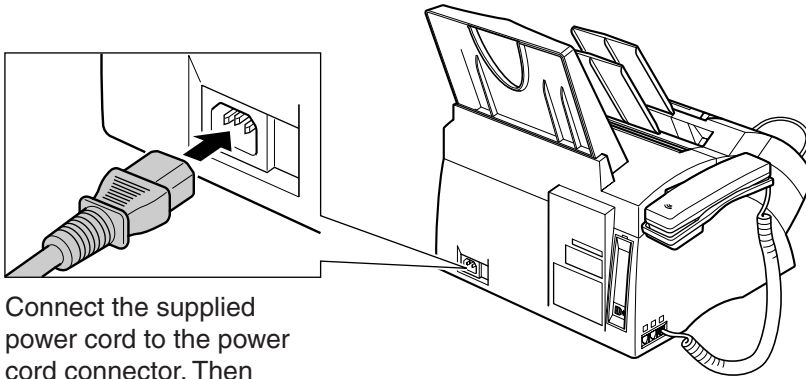

Connect the supplied power cord to the power cord connector. Then connect the other end into a properly grounded 120 V AC three-prong outlet.



- The machine is equipped with a three-prong, grounding-type plug provided with a third (grounding) pin. This plug will only fit into a grounding-type outlet. This is a safety feature. If you are unable to insert the plug into your outlet, contact an electrician to replace the outlet. Do not defeat the safety purpose of the grounding-type plug by breaking off the third prong or using a 3-to-2 adapter.
- Do not plug the machine into the same circuit as an appliance such as an air conditioner, electric typewriter, television, or copier. Such devices generate electrical noise that can interfere with your machine's ability to send and receive faxes.

The machine has no power switch, so its power is on as long as it is plugged in. When you connect the machine, the LCD displays these messages:

PLEASE WAIT

Machine is warming up.

12/19 FaxTel

Machine is in standby mode (date and receive mode displayed) and ready for use.

PUT IN CARTRIDGE

If the cartridge has not been installed, this message alternates with the standby mode display.

Connecting the FAXPHONE to Your PC

To connect your machine to a PC, you will need to purchase a USB cable suitable for the interface connector on your PC:

- A USB cable no longer than 16.4 feet (5 meters)

Follow this procedure to connect the appropriate cable:

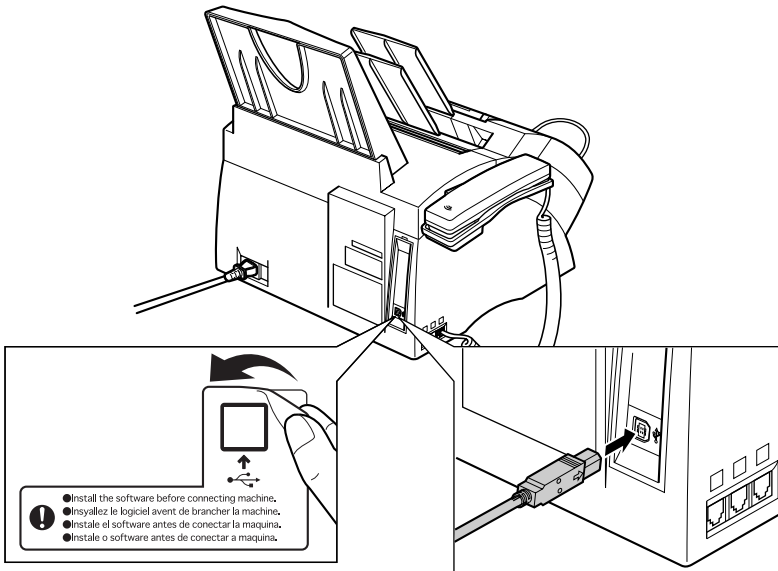

Remove the USB label.

To ensure proper operation of the printer driver, connect the USB cable to the machine and PC during software installation (→ *Software User's Guide*).



Note

Make sure your PC is running Microsoft Windows® 98/Me or Windows® 2000/XP, preinstalled by a computer manufacturer on purchase. (The USB port operation also needs to be assured by the manufacturer.)

Main Components of the FAXPHONE

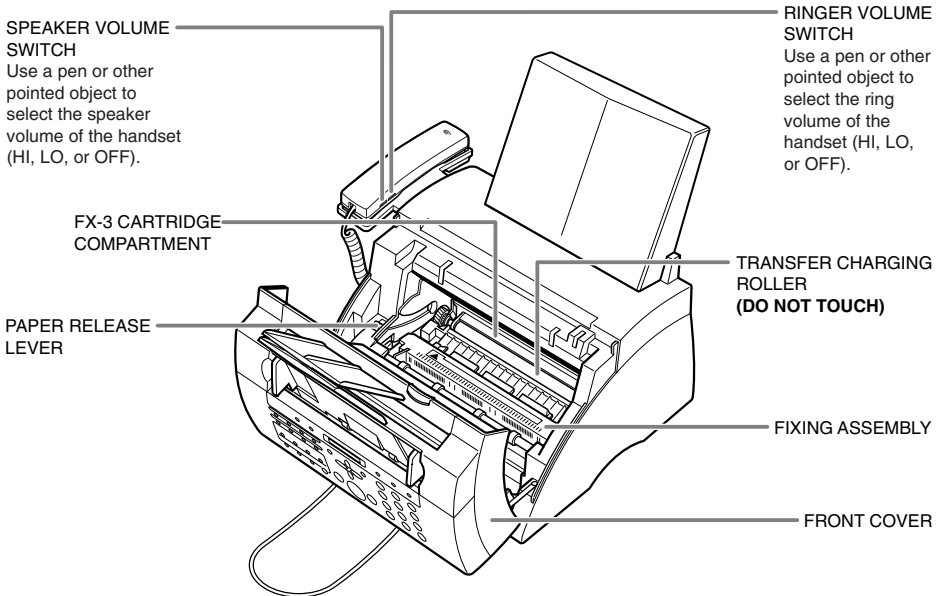
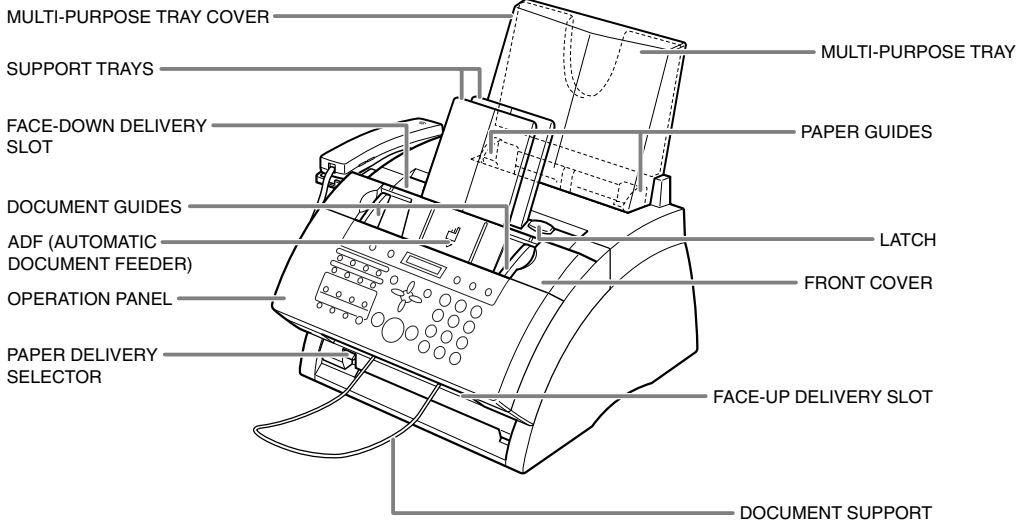

Operation Panel

- Directory Button
- Image Quality Button
- LCD
- Coded Dial Button
- Redial Button
- Pause Button
- Clear Button
- ◀▶▲▼ Buttons
- Set Button

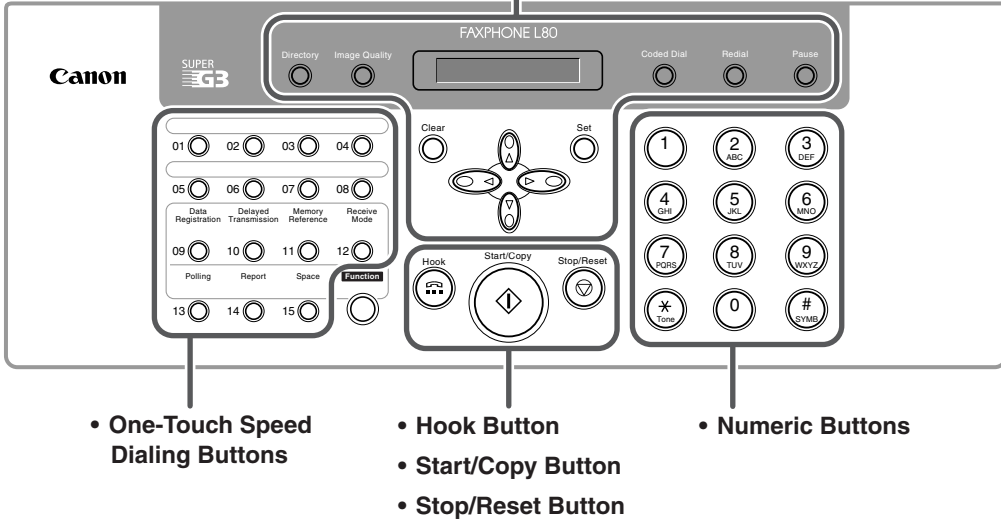

Special Function Buttons

- Data Registration Button
- Delayed Transmission Button
- Memory Reference Button
- Receive Mode Button

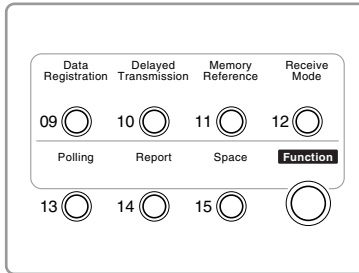

- Polling Button
- Report Button
- Space Button
- Function Button

LCD (Standby Mode)

- Date **12/26**
- **FaxTel**
- Receive Mode

Installing the Cartridge

This section describes how to install the cartridge in the machine for the very first time. If you are replacing a used cartridge, see p. 12-7.

Before installing the cartridge, be sure to read the following:

- Use only FX-3 cartridges in your machine. The FX-3 S Cartridge is a starter cartridge that comes with your machine, and yields approximately 1,500 pages of printouts.
- Keep the cartridge away from computer screens, disk drives, and floppy disks. The magnet inside the cartridge may harm these items.
- Do not store the cartridge in direct sunlight.
- Avoid locations subject to high temperature, high humidity, or rapid changes in temperature. Store the cartridge between 32°F and 95°F (0°C and 35°C).
- Do not expose the cartridge to direct sunlight or bright light for longer than five minutes.
- Store the cartridge in its protective bag. Do not open the bag until you are ready to install the cartridge in the machine.
- Save the cartridge's protective bag in case you need to repack and transport the cartridge at a later date.
- Do not store the cartridge in a salty atmosphere or where there are corrosive gases such as from aerosol sprays.
- Do not remove the cartridge from the machine unnecessarily.
- Do not open the drum protective shutter on the cartridge. Print quality may deteriorate if the drum surface is exposed to light or is damaged.
- Hold the cartridge by its handle so that your hand is not touching the drum protective shutter.
- Do not stand the cartridge on end, and do not turn it upside down. If toner becomes caked in the cartridge, it may prove impossible to free it even by shaking the cartridge.

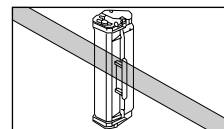
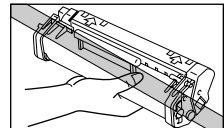
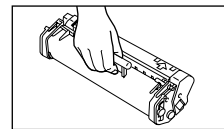
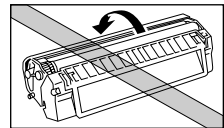

Do not place the cartridge in fire. Toner powder is flammable.

Follow this procedure to install the cartridge in the machine:

- 1 Make sure the machine is plugged in.
- 2 Lift the latch and open the front cover.

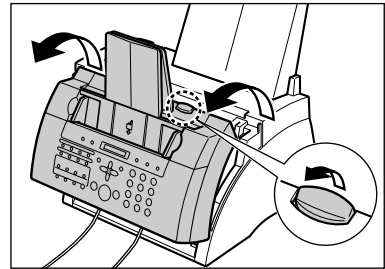

Do not try to open the front cover without lifting the latch since this may damage your machine.

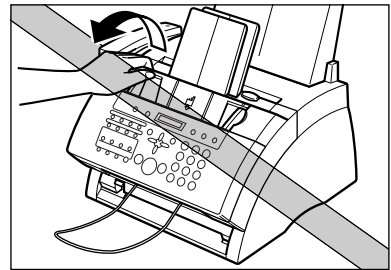

- 3 Remove the FX-3 S Cartridge from its protective bag.
 - Save the protective bag in case you need to repack the cartridge at a later date.
- 4 Gently rock the cartridge from side to side a few times to distribute the toner evenly inside it.
 - Poor print quality may result if the toner is unequally distributed.

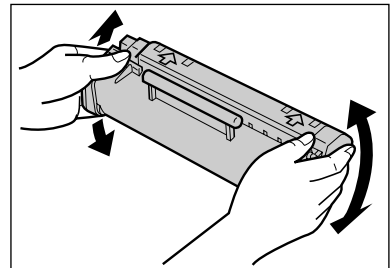

- 5** Place and support the cartridge on a flat, clean surface, then gently pull on the plastic tab to remove the plastic seal.
- Use a firm, even pull to avoid breaking the seal.

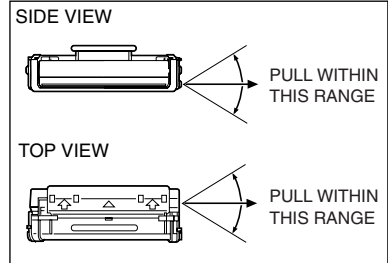
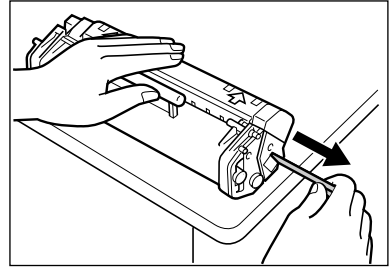

- 6** Hold the cartridge by its handle and insert it into the machine as far as it will go, making sure that its tabs are aligned with the rails inside the machine.
- Always hold the cartridge by its handle.

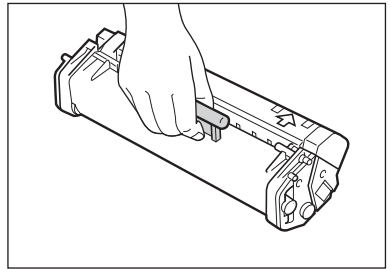
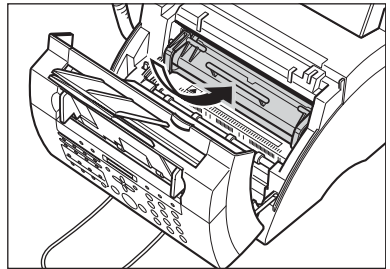

- 7** Use both hands to close the front cover.

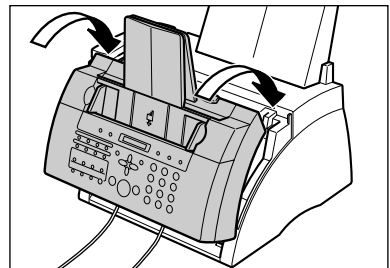

Loading Paper

This section explains how to load plain paper in the multi-purpose tray.

For complete details on paper and other print media for use with your machine, see Chapter 5.

Before loading paper, be sure to read the following:



The laser printing process uses high temperatures to fuse toner to the paper. Use paper that will not melt, vaporize, discolor, or emit dangerous fumes at temperatures near 338°F (170°C). For example, do not use vellum paper in a laser printer. Make sure any letterhead or colored paper you use can withstand high temperatures.

- Your machine supports regular copier paper, cotton bond paper, and typical letterhead paper. It does not require special media. Use cut-sheet paper only, not paper that comes on a roll.
- Be sure to load paper of the correct size, weight, and quantity recommended for your machine (→ Chapter 5).
- The multi-purpose tray is factory-set for loading letter-size paper, but you can change this setting to other paper sizes (→ p. 5-9).
- You can choose whether paper is delivered through the face-up or face-down delivery slot (→ p. 5-7). Choose according to the print media and task you are performing.
- The face-down delivery slot can hold up to approximately 50 sheets of paper. To prevent paper jams, remove paper from this slot before the count reaches 50.
- Do not load paper while the machine is printing.
- Do not leave paper stacked in the multi-purpose tray for long periods of time since it may bend or curl and cause problems.
- Certain environmental conditions, such as extreme temperatures or humidity, can cause some paper to misfeed in the multi-purpose tray. If you have trouble, feed one sheet at a time.
- Take care not to drop any foreign objects into the multi-purpose tray.
- Avoid mixing new stock with paper already loaded in the multi-purpose tray. Adding new stock without removing the paper already loaded will cause paper jams. If you must add new stock, remove the loaded paper and reload it together with the new stock.

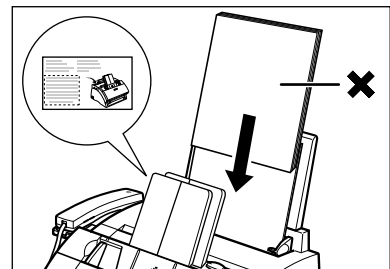

Follow this procedure to load a stack (max. 0.4 in./10 mm stack height) of letter-size plain paper in the multi-purpose tray:

- 1** Remove the multi-purpose tray cover from the machine.

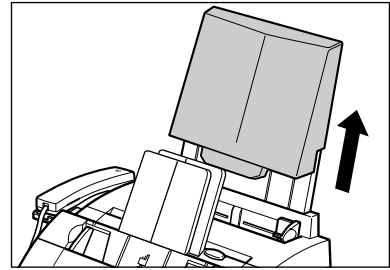

- 2** Prepare a stack of paper by tapping it on a flat surface to even its edges.

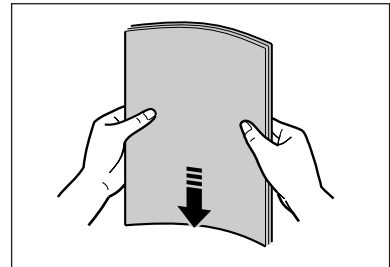

- 3** Open the paper guides to the approximate width of the stack.

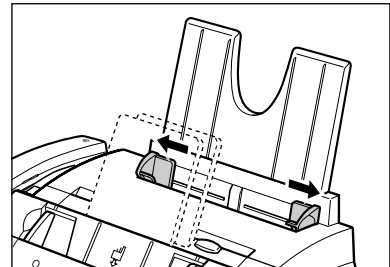

- 4** Insert the stack into the multi-purpose tray ① (print side facing you and top edge first), then adjust the paper guides to the width of the paper ②.
 - Make sure there are no gaps between the paper guides and the paper stack.

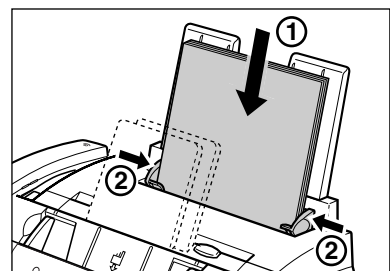

- 5** Replace the multi-purpose tray cover.
 - Be sure to replace this cover to prevent dust accumulating inside the machine.
- 6** Adjust the paper delivery selector if necessary (→ p. 5-7).



For details on how to change the paper size setting, see p. 5-9.

Testing the FAXPHONE

Once you have assembled your machine, installed the cartridge, and loaded paper, you can make sure your machine is printing properly by making several copies of a document (→ p. 10-2).

If you have problems printing, see Chapter 13.

Chapter 3

Registering Information

This chapter explains how to enter information in your machine. You will also find instructions for registering the sender information that you are required to enter.

Guidelines for Entering Numbers, Letters, and Symbols	3-2
Correcting a Mistake.....	3-4
Registering Required Sender Information	3-5
What is Sender Information?	3-5
Registering Your Sender Information.....	3-6
Setting the Telephone Line Type	3-8
Setting the Daylight Saving Time	3-9

Guidelines for Entering Numbers, Letters, and Symbols

When you come to a step that requires you to enter a name or number, refer to the table below to determine which numeric button to press for the character you need:

Button	Letters (:A)	Numbers (:1)
①		1
^{ABC} ②	ABCabc	2
^{DEF} ③	DEFdef	3
^{GHI} ④	GHIghi	4
^{JKL} ⑤	JKLjkl	5
^{MNO} ⑥	MNOmno	6
^{PQRS} ⑦	PQRSpqrs	7
^{TUV} ⑧	TUVtuv	8
^{WXYZ} ⑨	WXYZwxyz	9
^{OPER} ⑩		0
^{SYMB} ⑪	-.*#!";: ^ ` _ = / ! ' ? \$ @ % & + () [] { } < >	
^{Tone} ✳	Letter input (:A) ↔ Number input (:1)	



Note If you pause for more than 60 seconds between entering data, the machine will automatically return to standby mode.

■ Changing Between Number Mode and Letter Mode

Press ✳ to select number mode (:1) or letter mode (:A).

(Number mode)

(Letter mode)

■ Entering Letters

1 Press **✳** to switch to letter mode (:A).

_ :A

2 Press the numeric button that contains the letter you want.

C :A

- Press repeatedly until the letter you want appears. Each button cycles through the letters that it contains.
- If you are unsure which button to press for the letter you want, see p. 3-2.

3 Continue entering other letters using the numeric buttons.

CA :A

- If the next letter you want to enter is under a different numeric button, simply press that button until the letter you want appears.
-or-
If the next letter you want to enter is under the same numeric button you pressed in step 2, press **▶** to move the cursor to the right. Then press that same numeric button repeatedly until the letter you want appears.
- To enter a space, press **Function** then **Space**.

■ Entering Numbers

1 Press **✳** to switch to number mode (:1).

_ :1

2 Press the numeric button that contains the number you want.

1_ :1

- To enter a space, press **Function** then **Space**.

3 Continue entering other numbers using the numeric buttons.

10_ :1

■ Entering Symbols

1 Press **#** repeatedly until the symbol you want appears.

:1

2 If you want to enter another symbol, press **▶** to move the cursor to the right, then press **#** repeatedly until the symbol you want appears.

#_ :1

Correcting a Mistake

You can delete an entire entry by pressing **Clear**. Or, follow this procedure to correct individual characters:

- 1** Use ◀ or ▶ to move the cursor under the incorrect character.



CANEN :A

- 2** Press the numeric button that contains the correct letter, to enter it over the incorrect character.

- If you are unsure which button to press for the letter you want, see p. 3-2.



CANON :A

- 3** When you have finished making corrections, press **Set** to register your new entry.

Registering Required Sender Information

In the United States, FCC rules governing the use of facsimile equipment state that the following sender information **must** be printed on every facsimile transmission:

- Your fax number
- Your personal name or company name
- The time and date of transmission

Your machine has been designed to print this information at the top of every fax you send. You must therefore register your machine's telephone/fax number, your personal name or company name, and the current date and time before using your machine. This section gives details on registering your sender information.

What is Sender Information?

When you receive a fax, the name of the person or company who sent you the fax, their fax/telephone number, and the date and time of transmission will be printed in small type at the top of each page. This information is called the *Sender information* or the *Transmit Terminal Identification* (TTI). You must register your details in your machine so that whenever you send a fax, the other party knows who sent it, and when it was sent. Below is an example of how your sender information would print on a fax sent from your machine:

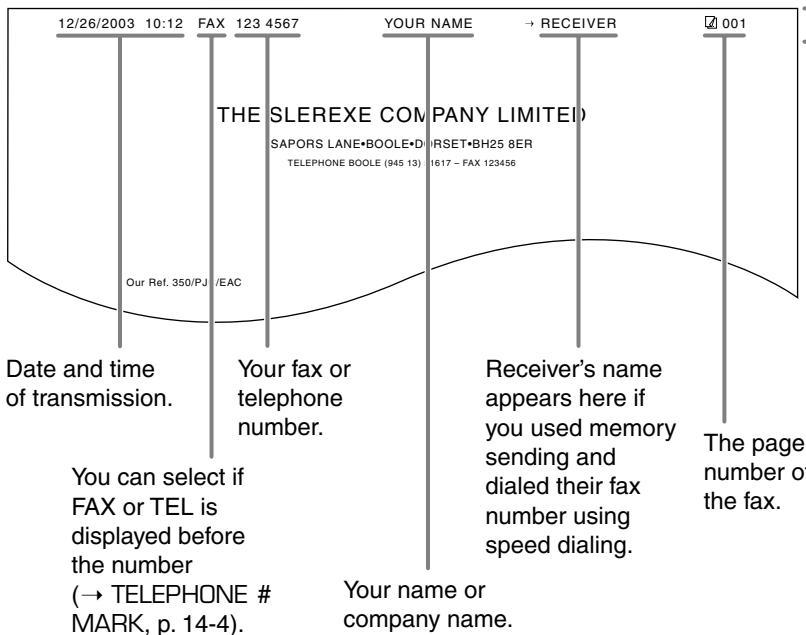

You can select if the sender information is printed inside or outside the image area (→ TTI POSITION, p. 14-4).

To enter the sender information in your machine, follow the procedures on the following pages.

Registering Your Sender Information

Follow this procedure to set the current date and time, register your fax/telephone number, and register your name or company name:

1 Press **Function**.

2 Press **Data Registration**.

DATA REGISTRATION

3 Press **Set** three times.

- The date and time currently set for your machine are displayed.

USER SETTINGS

DATE & TIME

12/19/2003 13:30

4 Use the numeric buttons to enter the correct month, day, year, and time in this order.

- Enter only the last two digits of the year.
- Use the 24-hour format for the time (e.g. 1:00 p.m. as 13:00), and precede single digits with a zero.
- If you make a mistake, press **Clear** and re-enter the date and time. You can also use ◀ or ▶ to move the cursor under the incorrect number and enter the correct number.

12/26/2003 15:00

5 Press **Set** twice.

UNIT TELEPHONE #

TEL=

6 Use the numeric buttons to enter your fax/telephone number (max. 20 digits, including spaces).

- To enter a space, press **Function** then **Space**. Spaces are optional but make the number easier to read.
- If you make a mistake, press **Clear** and re-enter the number. You can also use ◀ to delete the rightmost digit and enter the correct number.

TEL= 123 xxxx

7 Press **Set** twice.

UNIT NAME

_ :A

8 Use the numeric buttons to enter your name or company name (max. 24 characters, including spaces).

- If you are unsure how to enter characters, see p. 3-2.
- If you make a mistake, press **Clear** and re-enter the name. You can also use ◀ or ▶ to move the cursor under the incorrect letter and enter the correct letter.

CANON	:A
-------	----

9 Press **Set**.

TX TERMINAL ID

10 Press **Stop/Reset** to return to standby mode.

12/26	FaxTel
-------	--------



To check the sender information registered in your machine, you can print the USER'S DATA LIST (→ p. 14-2).

Setting the Telephone Line Type

Before using your machine, make sure it is set for the telephone line type of your telephone system. If you are unsure of your telephone line type, check with your local telephone company.

Your machine is factory-set to operate for tone dialing (TOUCH TONE setting). If you need to change this setting for pulse dialing (ROTARY PULSE setting), follow this procedure:

1 Press **Function**.

2 Press **Data Registration**.

DATA REGISTRATION

3 Press **Set** twice.

USER SETTINGS

DATE & TIME

4 Use ▼ or ▲ to select TEL LINE TYPE.

TEL LINE TYPE

5 Press **Set**.

TOUCH TONE

6 Use ▼ or ▲ to select ROTARY PULSE.

ROTARY PULSE

7 Press **Set**.

REPORT SETTINGS

8 Press **Stop/Reset** to return to standby mode.

12/26 FaxTel

Setting the Daylight Saving Time

This machine supports the daylight saving time system that shifts the clock time ahead or back according to the change in seasons. You can select whether the time information in your machine changes to match the daylight saving time system and set the day and time when the daylight saving time starts and ends.

The current settings can be checked by printing the User's Data List, see p. 14-2.

1 Press **Function**.

2 Press **Data Registration**.

DATA REGISTRATION

3 Press **Set**.

USER SETTINGS

4 Use ▼ or ▲ to select **SYSTEM SETTINGS**.

SYSTEM SETTINGS

5 Press **Set**.

RX RESTRICTION

6 Use ▼ or ▲ to select **DAYLGH T SAV TIME**.

DAYLGH T SAV TIME

7 Press **Set**.

OFF

8 Use ▼ or ▲ to select the setting you want.

- You can select from the following:

- ON

Enables the daylight saving time.

- OFF

Disables the daylight saving time.

OFF

■ **If you selected OFF in step 8:**

9 Press **Set**.

TEL REGISTRATION

10 Press **Stop/Reset** to return to standby mode.

12/26

FaxTel

■ **If you selected ON in step 8:**

9 Press **Set** to register your selection.

START DATE/TIME

10 Press **Set** to select START DATE/TIME.

MONTH

11 Press **Set** and press ▼ or ▲ to select the month when the daylight saving time starts, and press **Set** to register your selection.

APRIL

APRIL

WEEK



If you want to change your selection after pressing **Set**, press ▲ to return to your previous selection, make the necessary changes and press **Set**.

12 Press **Set** and press ▼ or ▲ to select the week when the daylight saving time starts, and press **Set** register your selection.

FIRST WEEK

• You can select from the following:

- FIRST WEEK
- SECOND WEEK
- THIRD WEEK
- FOURTH WEEK
- LAST WEEK (fifth week)

FIRST WEEK

13 Press **Set** and press ▼ or ▲ to select the day of the week when the daylight saving time starts, and press **Set** to register your selection.

DAY

SUNDAY

SUNDAY

14 Press **Set** and use the numeric buttons to enter the time when the daylight saving time compensation is made, and press **Set** to register your selection.

TIME

02:00

- Use the 24-hour format for the time (e.g. 2:00 p.m. as 14:00) and precede single digits with a zero.

02:00



If you make a mistake while entering the time, press **Clear** to clear your entry and enter the correct time. You can also use ◀ or ▶ to move the cursor under the incorrect number and enter the correct number.

15 Press **Set** to select END DATE/TIME.

END DATE/TIME

16 Press **Set** and use ▼ or ▲ to select the month, week, day of the week, and time when the daylight saving time ends, as in steps 11 to 14 for the START DATE/TIME settings. (e.g. OCTOBER LAST WEEK, SUNDAY and 02:00)

MONTH

OCTOBER

17 Press **Stop/Reset** to return to standby mode.

12/26 FaxTel

Chapter 4

Document Handling

This chapter describes the documents you can load in your machine for sending and copying.

Document Requirements	4-2
Scanned Area of a Document	4-2
Loading Documents	4-3
Adding Pages to the Document in the ADF	4-4

Document Requirements

The documents you load in the ADF for sending and copying must meet the following requirements:

	One-page document	Multipage document of the same thickness and weight
Size (W × L)	Min. 5.8 × 4.1 in. (Min. 148 × 105 mm) Max. 8.5 × Approx. 39.4 in. (Max. 216 mm × Approx. 1 m)	Min. 5.8 × 4.1 in. (Min. 148 × 105 mm) Max. 8.5 × 14 in. (Max. 216 × 356 mm)
Quantity	1 sheet	Max. 30 letter- or A4-size sheets* Max. 10 legal-size sheets*
Thickness	0.002 to 0.009 in. (0.06 to 0.23 mm)	0.002 to 0.005 in. (0.06 to 0.13 mm)
Weight	9.3 to 64 lb. (35 to 240 g/m ²)	10.7 to 24 lb. (40 to 90 g/m ²)

■ Problem Documents

- To prevent document jams in the ADF, do not use any of the following:
 - Wrinkled or creased paper
 - Carbon paper or carbon-backed paper
 - Curled or rolled paper
 - Coated paper
 - Torn paper
 - Onion skin or thin paper
- Remove all fasteners (staples, paper clips, etc.) before loading the document in the ADF.
- Make sure any glue, ink, or correction fluid on the document is completely dry before loading it in the ADF.
- If you have a document that will not feed properly in the ADF, make a photocopy of the document and load the copy instead.
- If you will be sending a document that you have printed from your machine, be sure to use face-down delivery when printing that document (→ p. 5-7).

Scanned Area of a Document

The shaded area shows the scanned area of a document. Make sure your document's text and graphics fall within this area.

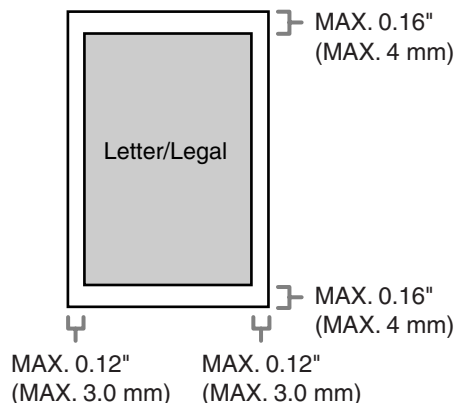

* 20 lb. (75 g/m²) paper

Loading Documents

Insert the top of your document, face down, into the ADF until you hear a beep ①. Then adjust the document guides to the width of the document ②.

- Tap multipage documents on a flat surface to even the edges before inserting them in the ADF.

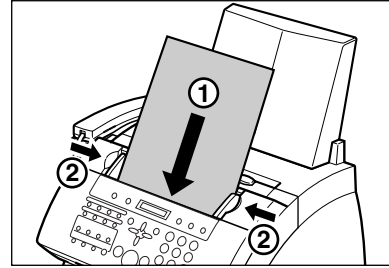

The document is now ready for scanning.



- For a multipage document, the pages are fed one by one from the bottom of the stack.
- Wait until all pages of your document have been scanned before starting a new job.

■ Problems With Multipage Documents

If you have trouble feeding multipage documents in the ADF, remove the stack and tap it on a flat surface to even the edges. Then “slant” the stack so that its front edge is bevelled, and insert the stack in the ADF.

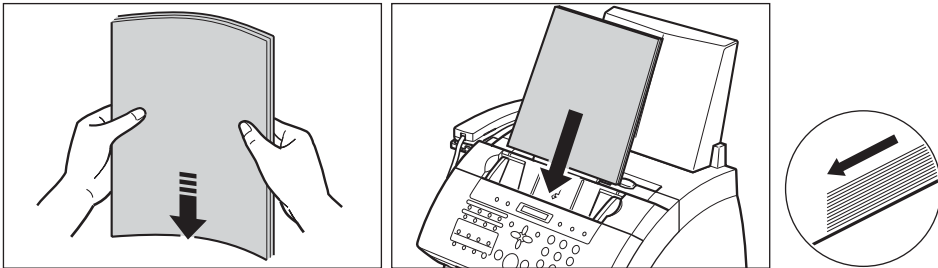

- To avoid feeding problems, make sure the document meets the document requirements (→ p. 4-2).

Adding Pages to the Document in the ADF

If you need to add pages to your document in the ADF, wait until the last page starts feeding, then load up to 30 additional pages (10 legal size). The last and first page should overlap by about one inch (2.5 cm).

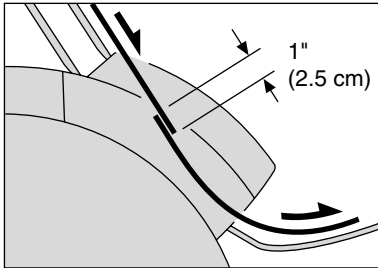

Chapter 5

Print Media Handling

This chapter describes the print media you can load in your machine, and other information related to print media and printing.

Print Media Requirements	5-2
Printable Areas	5-3
Selecting and Loading Print Media	5-4
Paper	5-4
Envelopes	5-4
Transparencies	5-6
Selecting Face-Up or Face-Down Delivery	5-7
Changing the Paper Size Setting	5-9
Adjusting the Toner Saver Setting	5-11

Print Media Requirements

You can load the following print media in the multi-purpose tray:

Print Media	Size (W × L)	Quantity & Weight	
Plain Paper	Min. 3.6 × 5 in. (92 × 127 mm)	Quantity: Max. stack height: 0.4 in./10 mm (Approx. 100 sheets of 20 lb. (75 g/m ²) paper) Weight: 17 to 24 lb. (64–90 g/m ²) 1 sheet: 17 to 28 lb. (64–105 g/m ²)	
	Max. 8.5 × 14 in. (216 × 356 mm)		
	LTR (Letter)		8.5 × 11 in. (216 × 279 mm)
	LGL (Legal)		8.5 × 14 in. (216 × 356 mm)
	A4		8.3 × 11.7 in. (210 × 297 mm)
	CUSTOM1/LONG*		8.5 × 12.5 in. to 8.5 × 13.4 in. (216 × 317 mm to 216 × 340 mm)*
CUSTOM2/SHORT*	8.5 × 10 in. to 8.5 × 11.2 in. (216 × 254 mm to 216 × 285 mm)*		
Envelopes	U.S. Commercial No. 10	9.5 × 4.1 in. (241 × 104 mm)	7 envelopes
	European DL	8.7 × 4.3 in. (220 × 110 mm)	
Transparencies	LTR (Letter)	8.5 × 11 in. (216 × 279 mm)	1 sheet
	A4	8.3 × 11.7 in. (210 × 297 mm)	

Once you have decided which paper you want to load, be sure to do the following:

- Check that the print media is compatible with your machine (→ p. 5-4).
- If you are loading paper, check that the paper size setting of the multi-purpose tray is set for the paper size you are loading (→ p. 5-9). (The default setting is letter size.)
- Check that paper delivery is set correctly for the print media and task you are performing (→ p. 5-7).
- Check that you have loaded the print media correctly in the multi-purpose tray (→ p. 5-4).

*For this setting, you may need to load fewer sheets.

Printable Areas

■ Paper

The shaded area shows the printable area of letter-size paper.

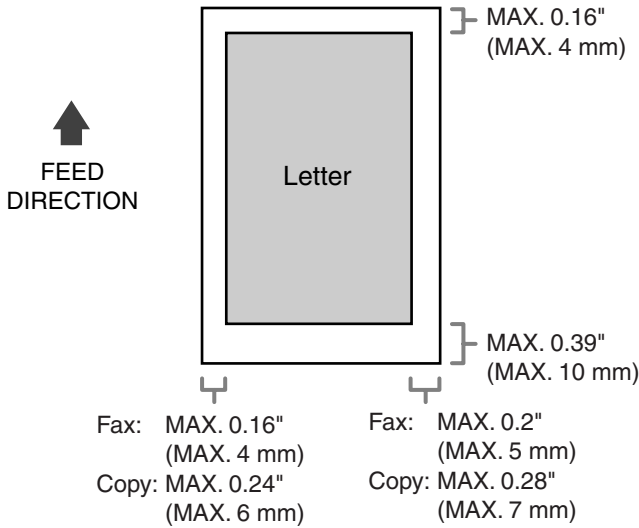

■ Envelope

The shaded area shows the printable area of U.S. Commercial No. 10-size envelopes.

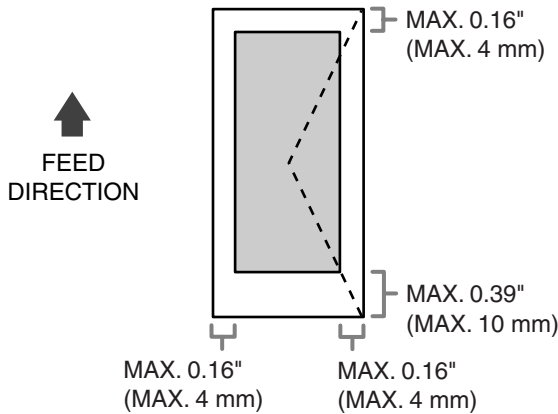

U.S. Commercial
No. 10

Selecting and Loading Print Media

Paper

■ Selecting Paper

- To prevent paper jams in the multi-purpose tray, do not use any of the following:
 - Wrinkled or creased paper
 - Curled or rolled paper
 - Coated paper
 - Torn paper
 - Damp paper
 - Onion skin or very thin paper
- The following types of paper do not print well:
 - Highly textured paper
 - Very smooth paper
 - Shiny paper
- Make sure the paper is free from dust, lint, and oil stains.
- Be sure to test paper before purchasing large quantities.
- Store all paper wrapped and on a flat surface until ready to use. Keep opened packs in their original packaging, in a cool, dry location.
- Store paper at 64.4°F–75.2°F (18°C–24°C), 40%–60% relative humidity.

■ Loading Paper

For instructions on loading paper in the multi-purpose tray, see p. 2-16.

Envelopes

■ Selecting Envelopes

- Use standard envelopes with diagonal seams and flaps.
- To prevent jams in the multi-purpose tray, do not use the following:
 - Envelopes with windows, holes, perforations, cutouts, and double flaps
 - Envelopes made with special coated paper or deeply embossed paper
 - Envelopes with peel-off sealing strips
 - Envelopes with letters enclosed
- You may be able to load other size envelopes than those listed on the previous page. However, Canon cannot guarantee consistent performance on these.



When printing on envelopes, be sure to use face-up delivery (→ p. 5-7).

Note

■ Loading Envelopes

Follow this procedure to load up to 7 envelopes in the multi-purpose tray:

1 Prepare the envelopes.

- Arrange the stack of envelopes on a firm, clean surface, and press down firmly on the edges to make the folds crisp.

- Press all the way around the envelopes to remove any curls and expel air from inside the envelopes. Also, press firmly on the area that corresponds to the edges of the back flap.

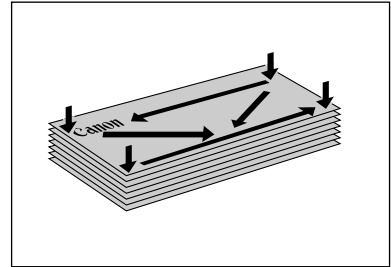

- Remove any curling from the envelopes by holding the edges diagonally and bending them gently.

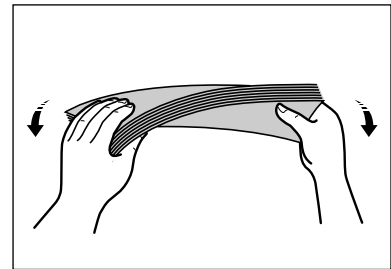

- Run a pen or other rounded object along the back flaps to flatten them.

- The flaps should not bulge more than 0.2 in. (5 mm).

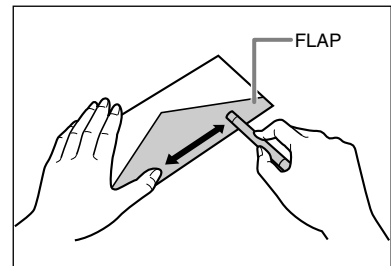

2 Remove the multi-purpose tray cover from the machine.

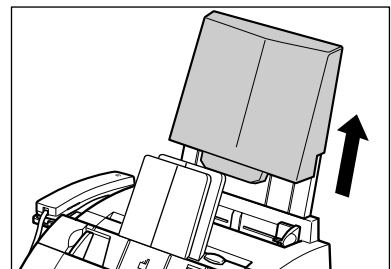

- 3** Insert the stack into the multi-purpose tray ① (print side facing you), then adjust the paper guides to the width of the stack ②.

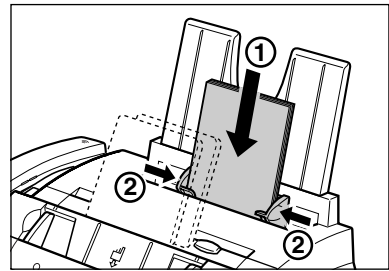

- 4** Replace the multi-purpose tray cover.
- Be sure to replace this cover to prevent dust accumulating inside the machine.
- 5** Adjust the paper delivery selector to  (face-up delivery). For details, see p. 5-7.

The machine is now ready to print.

Transparencies

■ Selecting Transparencies

Use only special laser printer transparencies.



Note

- When printing on transparencies, be sure to use face-up delivery (→ p. 5-7).
- To prevent the transparency from curling, remove it as soon as it exits the machine and place it on a flat surface to cool.

■ Loading Transparencies

Load transparencies in the multi-purpose tray as for paper (→ p. 2-16). However, load only one transparency at a time.

Selecting Face-Up or Face-Down Delivery

■ Paper Path

Understanding how paper feeds through the machine will help you determine which paper delivery slot is appropriate for the print media and task you are performing.

First, the paper travels to the cartridge where a laser beam “draws” the print image on the drum, which in turn applies toner to the paper. The paper travels to the fixing assembly where the toner is “fixed” (fused) to the paper. It then exits the machine through the face-up delivery slot (front of the machine) or the face-down delivery slot (top of the machine).

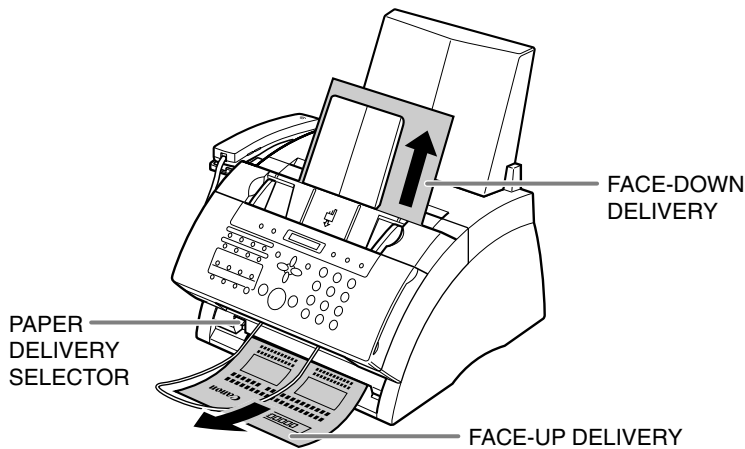

■ Before Setting the Paper Delivery Selector

Before selecting paper delivery, be sure to take note of the following:

- Always set the paper delivery selector before printing.
- Changing paper delivery while the machine is printing will cause problems. Wait for the printout to exit the machine completely before changing paper delivery.
- The face-down delivery slot can hold up to approximately 50 sheets of paper. To prevent paper jams, remove paper from this slot before 50 sheets print out.
- Make sure there is enough room for the paper to exit from the face-up delivery slot. Remove each sheet as it is delivered from this slot.
- Never pull the paper as it comes out of the machine.

- Select face-down delivery when:
 - printing on paper.
 - you want the printed pages to stack in the correct page order.
 - you are printing a small number of pages.
 - you only receive a small number of faxes, and of few pages.
 - you will be faxing a document you have printed from your machine.
- Select face-up delivery when:
 - printing on envelopes.
 - printing on transparencies.
 - you are expecting to print or receive a large number of pages, or plan to be away and want to receive faxes during your absence. If this is the case, place your machine near the edge of a table so that the pages can fall away from your machine without blocking the face-up delivery slot. Place a container below your machine to collect the pages.

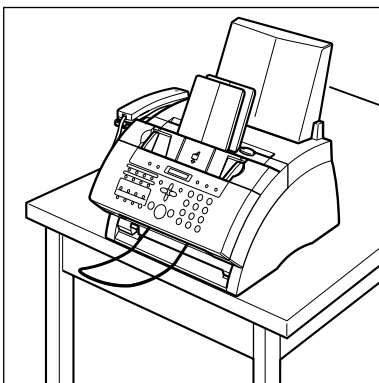

■ Setting the Paper Delivery Selector

Select face-up or face-down delivery with the paper delivery selector.

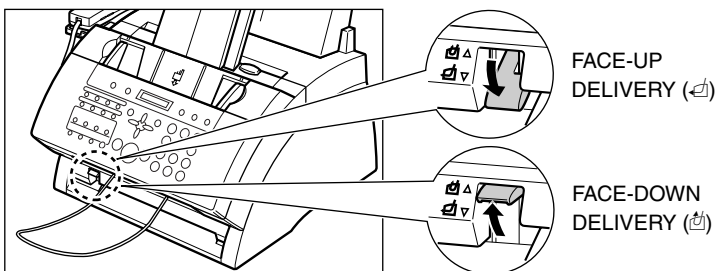

When using face-up delivery, you must remove each sheet as it is delivered. Failure to do this may cause jams in the face-up delivery slot and result in damage to your machine.

Changing the Paper Size Setting

The multi-purpose tray is factory-set for loading letter-size paper. If you want to load a different paper size (→ p. 5-2), follow this procedure to change the paper size setting:

1 Press **Function**.

2 Press **Data Registration**.

DATA REGISTRATION

3 Press **Set**.

USER SETTINGS

4 Use ▼ or ▲ to select **PRINTER SETTINGS**.

PRINTER SETTINGS

5 Press **Set**.

RX REDUCTION

6 Use ▼ or ▲ to select **PAPER SIZE**.

PAPER SIZE

7 Press **Set**.

LTR

8 Use ▼ or ▲ to select the paper size you want for the multi-purpose tray.

- You can select from the following:
 - LTR
 - LGL
 - CUSTOM
 - A4
- For details on the paper sizes above, see p. 5-2.

■ **If you selected LTR, LGL, or A4 in step 8:**

9 Press **Set**.

ECONOMY PRT

10 Press **Stop/Reset** to return to standby mode.

12/26 FaxTel

■ **If you selected CUSTOM in step 8:**

9 Press **Set**.

CUSTOM1/LONG

10 Use ▼ or ▲ to select the custom paper size setting.

- You can select from the following:
 - CUSTOM1/LONG
 - CUSTOM2/SHORT
- For details on the paper sizes above, see p. 5-2.

11 Press **Set**.

ECONOMY PRT

12 Press **Stop/Reset** to return to standby mode.

12/26

FaxTel

Adjusting the Toner Saver Setting

By enabling the toner saver setting, you can reduce toner consumption of the cartridge by approximately 30% to 40%. This will extend the cartridge life.



By enabling this setting, print quality will be reduced. For highest print quality, disable this setting.

Follow this procedure to enable or disable the toner saver setting:

1 Press **Function**.

2 Press **Data Registration**.

DATA REGISTRATION

3 Press **Set**.

USER SETTINGS

4 Use ▼ or ▲ to select **PRINTER SETTINGS**.

PRINTER SETTINGS

5 Press **Set**.

RX REDUCTION

6 Use ▼ or ▲ to select **ECONOMY PRT**.

ECONOMY PRT

7 Press **Set**.

OFF

8 Use ▼ or ▲ to select the setting you want.

- You can select from the following:
 - ON (Enable toner saving)
 - OFF (Disable toner saving)

9 Press **Set**.

TONER SUPPLY LOW

10 Press **Stop/Reset** to return to standby mode.

12/26 FaxTel

Chapter 6

Speed Dialing

This chapter describes how to register and use speed dialing.

What is Speed Dialing?	6-2
Speed Dialing Methods	6-2
Registering One-Touch Speed Dialing	6-3
Registering Coded Speed Dialing	6-8
Registering Group Dialing	6-13
Using Speed Dialing	6-16
Sending a Document With Speed Dialing	6-16
Making a Telephone Call With Speed Dialing	6-17
Dialing with the Directory	6-18
Printing Speed Dialing Lists	6-19

What is Speed Dialing?

Instead of having to dialing a fax or telephone number using regular dialing (e.g. with the numeric buttons), you can simplify the dialing procedure by registering the fax/telephone number for speed dialing. This will reduce the number of buttons you need to press to dial the fax/telephone number, making it convenient for frequently dialed numbers.

Speed dialing also allows you to register several fax numbers under one speed dialing button or code so that you can send a document to all those fax numbers in one operation.

You can also look up a fax/telephone number quickly using the directory function.

See below for details on the different speed dialing methods.

Speed Dialing Methods

Your machine offers the following speed dialing methods:

■ One-Touch Speed Dialing (→ p. 6-3)

Register a fax/telephone number under a one-touch speed dialing button so that you only have to press one button to dial that fax/telephone number.

There are 15 one-touch speed dialing buttons available for you to register fax/telephone numbers.

■ Coded Speed Dialing (→ p. 6-8)

Register a fax/telephone number under a coded speed dialing code so that you only have to press **Coded Dial** and enter the registered two-digit code (with the numeric buttons) to dial that fax/telephone number.

There are 100 codes available for you to register fax/telephone numbers.

■ Group Dialing (→ p. 6-13)

“Group” up to 114 fax numbers together, so you can send to those fax numbers in one quick operation. A group is registered under a one-touch speed dialing button or a coded speed dialing code.

■ Directory Dialing (→ p. 6-18)

Use the **Directory** button to look up the fax/telephone numbers you registered for one-touch speed dialing, coded speed dialing, and group dialing.

Registering One-Touch Speed Dialing

By registering a fax/telephone number under a one-touch speed dialing button, you can simplify dialing of that number to the press of a single button.

When you register one-touch speed dialing, you will:

- assign one of the 15 one-touch speed dialing buttons for the fax/telephone number you want to register.
- register the fax/telephone number under that one-touch speed dialing button.
- register a name for the one-touch speed dialing button. This name appears in speed dialing lists, in reports, and at the top of the recipient’s fax if you use memory sending (→ p. 7-5).
- set the transmission type for the fax number you have registered. You can set a subaddress and/or password if the other party’s fax machine requires these settings.

Follow this procedure to register one-touch speed dialing:

1 Press **Function**.

2 Press **Data Registration**.

DATA REGISTRATION

3 Use ▼ or ▲ to select **TEL REGISTRATION**.

TEL REGISTRATION

4 Press **Set** twice.

1-TOUCH SPD DIAL

O1=

5 Use ▼ or ▲ to select the one-touch speed dialing button (O1 to 15) under which you want to register the fax/telephone number.

O4=

- If a one-touch speed dialing button has already been registered, the number registered under that button appears.
- If a group is already registered under a one-touch speed dialing button, **GROUP DIAL** appears.

6 Press **Set** twice.

TELEPHONE NUMBER

TEL=_

7 Use the numeric buttons to enter the fax/telephone number you want to register (max. 120 digits, including spaces and pauses).

TEL=20 5xx xxxx_

- To enter a space, press **Function** then **Space**. Spaces are optional and are ignored during dialing.
- To enter a pause, press **Pause** (→ p. 9-2).
- To correct a mistake in the number, press ◀ to delete the rightmost digit. Alternatively, press **Clear** to delete the entire number.
- To cancel one-touch speed dialing for the button you selected, press **Clear** then **Set**. Press **Stop/Reset** to return to standby mode. The fax/telephone number and name registered under that button will be deleted.
- If you have already registered a number that you want to keep, ignore this step.

8 Press **Set** twice.

NAME

_ :A

9 Use the numeric buttons to enter a name for the one-touch speed dialing button (max. 16 characters, including spaces).

Canon EUROPA :A

- If you are unsure how to enter characters, see p. 3-2.
- If you have already registered a name that you want to keep, ignore this step.

10 Press **Set**.

OPTIONAL SETTING

11 This completes the basic one-touch speed dialing settings.

To continue registering other one-touch speed dialing buttons, press **Set** twice and repeat the procedure from step 5.

-or-

To end registering one-touch speed dialing buttons, press **Stop/Reset** to return to standby mode.

-or-

To register the transmission type for the current button you are registering, continue with the steps below.

05=

12/26 FaxTel

12 Press **Set**.

OFF

13 Use ▼ or ▲ to select ON.

ON

14 Press **Set** twice.

TX TYPE

REGULAR TX

15 Use ▼ or ▲ to select the transmission type setting you want.

- You can select from the following:
 - REGULAR TX
Normal transmission.
 - PSWD/SUBADDRESS
Transmission with a subaddress and/or password. For details, see the following page.

■ **If you selected REGULAR TX in step 15:**

16 Press **Set**.

05=

17 Press **Stop/Reset** to return to standby mode.

12/26 FaxTel

■ **If you selected PSWD/SUBADDRESS in step 15:**

The other party's fax machine may require an ITU-T-standard subaddress and/or password to receive faxes. The subaddress/password you register here must match exactly the one(s) registered on the other party's fax machine. Contact the other party to check their settings.

When sending with a subaddress/password, the other party's fax machine receives the fax only if your subaddress/password matches theirs. Their fax machine then handles the received fax according to the feature they are using.

You also need to register a subaddress/password when polling a fax machine that requires these settings (→ p. 9-9).

Continue with the steps below to register a subaddress/password:

16 Press **Set** twice.

SUBADDRESS

17 If a subaddress is required, use the numeric buttons to enter it (max. 20 digits).

1234

- If a subaddress is not required, ignore this step.
- If you have already registered a subaddress that you want to keep, ignore this step.

18 Press **Set** twice.

PASSWORD

19 If a password is required, use the numeric buttons to enter it (max. 20 digits).

4321

- If a password is not required, ignore this step.
- If you have already registered a password that you want to keep, ignore this step.

20 Press **Set**.

05=

21 To continue registering other one-touch speed dialing buttons, repeat the procedure from step 5.

-or-

Press **Stop/Reset** to return to standby mode.

12/26

FaxTel



Note

- Use the destination labels provided with your machine to label the one-touch speed dialing buttons. Stick the labels above each corresponding button.
- To check your entries, you can print a list of all the numbers and names registered for one-touch speed dialing (→ p. 6-19).

Registering Coded Speed Dialing

By registering a fax/telephone number under a coded speed dialing code, you can simplify dialing of that number to pressing **Coded Dial** and entering the registered two-digit code.

When you register coded speed dialing, you will:

- assign one of the 100 codes for the fax/telephone number you want to register.
- register the fax/telephone number under that coded speed dialing code.
- register a name for the coded speed dialing code. This name appears in speed dialing lists, in reports, and at the top of the recipient's fax if you use memory sending (→ p. 7-5).
- set the transmission type for the fax number you have registered. You can set a subaddress and/or password if the other party's fax machine requires these settings.

Follow this procedure to register coded speed dialing:

1 Press **Function**.

2 Press **Data Registration**.

DATA REGISTRATION

3 Use ▼ or ▲ to select TEL REGISTRATION.

TEL REGISTRATION

4 Press **Set**.

1-TOUCH SPD DIAL

5 Use ▼ or ▲ to select CODED SPEED DIAL.

CODED SPEED DIAL

6 Press **Set**.

*00=

7 Use ▼ or ▲ to select the coded speed dialing code (00 to 99) under which you want to register the fax/telephone number.

*01=

- Alternatively, press **Coded Dial** and use the numeric buttons to enter the code.
- If a coded speed dialing code has already been registered, the number registered under that code appears.
- If a group is already registered under a coded speed dialing code, GROUP DIAL appears.

8 Press **Set** twice.

TELEPHONE NUMBER

TEL=_

9 Use the numeric buttons to enter the fax/telephone number you want to register (max. 120 digits, including spaces and pauses).

TEL=3 37xx xxxx_

- To enter a space, press **Function** then **Space**. Spaces are optional and are ignored during dialing.
- To enter a pause, press **Pause** (→ p. 9-2).
- To correct a mistake in the number, press ◀ to delete the rightmost digit. Alternatively, press **Clear** to delete the entire number.
- To cancel coded speed dialing for the code you selected, press **Clear** then **Set**. Press **Stop/Reset** to return to standby mode. The fax/telephone number and the name registered under that code will be deleted.
- If you have already registered a number that you want to keep, ignore this step.

10 Press **Set** twice.

NAME

_ :A

11 Use the numeric buttons to enter a name for the coded speed dialing code (max. 16 characters, including spaces).

Canon Inc_ :A

- If you are unsure how to enter characters, see p. 3-2.
- If you have already registered a name that you want to keep, ignore this step.

12 Press **Set**.

OPTIONAL SETTING

13 This completes the basic coded speed dialing settings.

To continue registering other coded speed dialing codes, press **Set** twice and repeat the procedure from step 7.

-or-

To end registering coded speed dialing codes, press **Stop/Reset** to return to standby mode.

-or-

To register the transmission type for the current code you are registering, continue with the steps below.

*02=

12/26 FaxTel

14 Press **Set**.

OFF

15 Use ▼ or ▲ to select ON.

ON

16 Press **Set** twice.

TX TYPE

REGULAR TX

17 Use ▼ or ▲ to select the transmission type setting you want.

- You can select from the following:
 - REGULAR TX
Normal transmission.
 - PSWD/SUBADDRESS
Transmission with a subaddress and/or password. For details, see the following page.

■ **If you selected REGULAR TX in step 17:**

18 Press **Set**.

*02=

19 Press **Stop/Reset** to return to standby mode.

12/26 FaxTel

■ **If you selected PSWD/SUBADDRESS in step 17:**

The other party's fax machine may require an ITU-T-standard subaddress and/or password to receive faxes. The subaddress/password you register here must match exactly the one(s) registered on the other party's fax machine. Contact the other party to check their settings.

When sending with a subaddress/password, the other party's fax machine receives the fax only if your subaddress/password matches theirs. Their fax machine then handles the received fax according to the feature they are using.

You also need to register a subaddress/password when polling a fax machine that requires these settings (→ p. 9-9).

Continue with the steps below to register a subaddress/password:

18 Press **Set** twice.

SUBADDRESS

19 If a subaddress is required, use the numeric buttons to enter it (max. 20 digits).

1234

- If a subaddress is not required, ignore this step.
- If you have already registered a subaddress that you want to keep, ignore this step.

20 Press **Set** twice.

PASSWORD

21 If a password is required, use the numeric buttons to enter it (max. 20 digits).

4321

- If a password is not required, ignore this step.
- If you have already registered a password that you want to keep, ignore this step.

22 Press **Set**.

*02=

23 To continue registering other coded speed dialing codes, repeat the procedure from step 7.

-or-

Press **Stop/Reset** to return to standby mode.

12/26 FaxTel



Note To check your entries, you can print a list of all the numbers and names registered for coded speed dialing (→ p. 6-19). You may want to keep this list near your machine to refer to it when dialing.

Registering Group Dialing

If you frequently send documents to the same group of fax numbers, you can “group” these numbers under a one-touch speed dialing button or coded speed dialing code. You can then send to all the fax numbers in the group in one quick and simple operation.

When you register group dialing, you will:

- assign a one-touch speed dialing button or a coded speed dialing code for the group of fax numbers you want to register.
- group up to 114 fax numbers under that button or code. The fax numbers must already be registered for one-touch or coded speed dialing (e.g. you cannot enter the fax numbers with the numeric buttons).
- register a name for the group. This name appears in speed dialing lists.

Follow this procedure to register group dialing:

1 Press **Function**.

2 Press **Data Registration**.

DATA REGISTRATION

3 Use ▼ or ▲ to select TEL REGISTRATION.

TEL REGISTRATION

4 Press **Set**.

1-TOUCH SPD DIAL

5 Use ▼ or ▲ to select GROUP DIAL.

GROUP DIAL

6 Press **Set**.

01=1-TOUCH SPD

7 Select a one-touch speed dialing button or coded speed dialing code under which you want to register the group.

■ **To register a group under a one-touch speed dialing button:**

Use ▼ or ▲ to select the one-touch speed dialing button (01 to 15) under which you want to register the group.

03=

- If a one-touch speed dialing button has already been registered, 1-TOUCH SPD or GROUP DIAL appears.

■ **To register a group under a coded speed dialing code:**

Press **Coded Dial**, then use the numeric buttons to enter the coded speed dialing code (00 to 99) under which you want to register the group.

- If a coded speed dialing code has already been registered, CODED SPEED or GROUP DIAL appears.



Note

If you wish to register a group under a button or code already registered for speed dialing, you must delete the previous information first (→ pp. 6-3, 6-8).

*21=

8 Press **Set** twice.

TELEPHONE NUMBER

TEL=

9 Enter the one-touch and/or coded speed dialing numbers you want to register in the group.

■ **To enter a fax number registered for one-touch speed dialing:**

Press the one-touch speed dialing button(s) assigned to the number(s) you want to register in the group.

01=Canon EUROPA

■ **To enter a fax number registered for coded speed dialing:**

Press **Coded Dial**, then use the numeric buttons to enter the two-digit code assigned to the number you want to register in the group. Repeat for other codes.

*

*01=Canon Inc.

- The name registered under the button or code you enter appears.
- The number registered under the one-touch speed dialing button or coded speed dialing code you enter appears. GROUP DIAL appears if you select a group.
- You cannot enter numbers not registered for one-touch or coded speed dialing (e.g. with the numeric buttons).

- To add fax numbers to a previously registered group, simply enter them as explained in this step.
- If you enter the wrong destination, or if you want to delete a destination already registered in a group, use ▼ or ▲ to select that entry, then press **Clear**.
- To cancel group dialing for the button or code you selected, press **Clear** until all entries are deleted, then press **Set**. Press **Stop/Reset** to return to standby mode. All fax numbers and the name of the group registered under that button or code will be deleted.

10 Press **Set** twice.

NAME

_ :A

11 Use the numeric buttons to enter a name for the group (max.16 characters, including spaces).

- If you are unsure how to enter characters, see p. 3-2.
- If you have already registered a name that you want to keep, ignore this step.

Canon GROUP 2_ :1

12 Press **Set**.

04=1-TOUCH SPD

13 To continue registering other groups, repeat the procedure from step 7.

-or-

Press **Stop/Reset** to return to standby mode.

12/26 FaxTel



Note

- If you registered groups under one-touch speed dialing buttons, use the destination labels provided with your machine to label the buttons. Stick the labels above each corresponding button.
- To check your entries, you can print a list of all the numbers and names registered for group dialing (→ p. 6-19). You may want to keep this list near your machine to refer to it when dialing.

Using Speed Dialing

Once you have registered fax/telephone numbers for one-touch speed dialing (→ p. 6-3), coded speed dialing (→ p. 6-8), or group dialing (→ p. 6-13), you can begin to send documents or make telephone calls with speed dialing.

Sending a Document With Speed Dialing

Follow this procedure to send a document using one-touch speed dialing, coded speed dialing, or group dialing:

- 1** Load the document, face down in the ADF (→ p. 4-3).
 - To adjust the resolution and contrast, see pp. 7-2, 7-3.
 - You may be unable to send if the memory used (shown in the LCD) is close to 100%. To free up space in the machine's memory: print, send, or delete any documents you no longer need to be stored in memory (→ p. 9-4).

MEMORY USED 0%

(Currently used memory)

DOCUMENT READY

(Standby to scan)

- 2** Enter the one-touch speed dialing button or coded speed dialing code assigned to the fax number or group you want to send to.

■ One-touch speed dialing button:

Press the one-touch speed dialing button you want.

■ Coded speed dialing code:

Press **Coded Dial**, then use the numeric buttons to enter the two-digit code you want.

- If you make a mistake, press **Stop/Reset** and repeat this step.
- NO TEL # appears if no fax/telephone number or group is assigned to the speed dialing button or code you pressed.

- 3** Press **Start/Copy** to begin scanning for sending, or wait a few seconds for your machine to begin scanning automatically.

- If you do not want your machine to begin scanning automatically after a few seconds, disable the TIME OUT setting (→ p. 14-6).

Making a Telephone Call With Speed Dialing

Follow this procedure to dial a telephone number registered for one-touch or coded speed dialing on your machine:

- 1** Make sure you have connected the handset or an extension telephone to your machine (→ p. 2-8).
- 2** Press **Hook**.
 - You can also lift the handset instead of pressing **Hook**.
- 3** Enter the one-touch speed dialing button or coded speed dialing code assigned to the telephone number you want to dial.
 - **One-touch speed dialing button:**
Press the one-touch speed dialing button you want.
 - **Coded speed dialing code:**
Press **Coded Dial**, then use the numeric buttons to enter the two-digit code you want.
 - If you make a mistake, press **Hook** or hang up the handset and start again from step 2.
 - NO TEL # appears if no fax/telephone number is assigned to the speed dialing button or code you pressed.
 - NOT AVAILABLE appears if you entered a speed dialing button or code assigned to a group of fax numbers.
- 4** When you hear the other party answer the call, pick up the handset to start talking.
- 5** When you are finished, simply hang up.

TEL=

Dialing with the Directory

Even if you forget under which of the one-touch speed dialing buttons, coded speed dialing codes, or groups you registered a particular fax/telephone number, the directory function allows you to look up and dial the correct number from the first letter of the other party's name.

Follow this procedure to send a document with the directory function:

1 Load the document, face down in the ADF (→ p. 4-3).

- To adjust the resolution and contrast, see pp. 7-2, 7-3.

2 Press **Directory**.

1ST LETT OF NAME

3 Use the numeric buttons to enter the first letter of the other party's name you are looking for.

01=Canon EUROPA

4 Press ▼ or ▲ to scroll through the names until the name you are looking for appears.

- If you press ▼ when the last entry in the directory is displayed, the list returns to the first entry in the directory.
- A two-digit number appears next to the name registered under a one-touch speed dialing button. An asterisk (✳) and a two-digit number appear next to the name registered under a coded speed dialing code.
- After the name appears, you can display the registered fax/telephone number by pressing ◀ or ▶.

5 Press **Start/Copy** to begin scanning for sending, or if you press **Set** instead, wait a few seconds for the machine to begin scanning automatically.

✳ 01=Canon Inc.

- To cancel sending once dialing has started, press **Stop/Reset** then ✳ (→ p. 7-8).

Printing Speed Dialing Lists

To check the fax/telephone numbers and names registered for speed dialing, you can print the speed dialing lists. You may want to keep these lists near your machine to refer to them when dialing.

Follow this procedure to print speed dialing lists:

1 Press **Function**.

2 Press **Report**.

ACTIVITY REPORT

3 Use ▼ or ▲ to select SPEED DIAL LIST.

SPEED DIAL LIST

4 Press **Set**.

1-TOUCH LIST

5 Use ▼ or ▲ to select the list you want to print.

- You can select from the following:
 - 1-TOUCH LIST
 - CODED DIAL LIST
 - 1-TOUCH (DETAIL)
 - CODED (DETAIL)
 - GROUP DIAL LIST

■ If you selected GROUP DIAL LIST in step 5:

6 Press **Set**.

- The machine prints the list.

■ If you selected a list other than GROUP DIAL LIST in step 5:

6 Press **Set**.

SORTED OUTPUT

YES={*} NO={#}

7 Select in what order you want the lists to be printed.

Press * to print the list with the destination names (CONNECTION ID on the reports) in alphabetical order (sorted).

-or-

Press # to print the list in code or button order (unsorted).

- The machine prints the list.

Samples of the lists are shown on the following pages.

■ 1-TOUCH SPD DIAL LIST 1

12/26/2003 17:23 FAX 123 4567 CANON 001

12/26/2003 17:23 FAX 123 4567 CANON 001

*** 1-TOUCH SPD DIAL LIST 1 ***

NO.	CONNECTION TEL	CONNECTION ID	TX TYPE
[12]	2 887 0166	Canon AUSTRALIA	REGULAR TX
[01]	905 795 1111	Canon CANADA	REGULAR TX
[03]	GROUP DIAL	Canon GROUP 2	REGULAR TX
[04]	2 50921	Canon ITALIA	REGULAR TX
[05]	1 432 2060	Canon OPTICS	PSWD/SUBADD.

IF YOU PRESS # IN STEP 7 (→ p. 6-19),
THE DESTINATIONS ARE LISTED IN
BUTTON ORDER (UNSORTED).

IF YOU PRESS * IN STEP 7 (→ p. 6-19),
THE DESTINATIONS ARE LISTED IN
ALPHABETICAL ORDER (SORTED).

■ 1-TOUCH SPD DIAL LIST 2 (Detailed List)

12/26/2003 17:23 FAX 123 4567 CANON 001

12/26/2003 17:23 FAX 123 4567 CANON 001

*** 1-TOUCH SPD DIAL LIST 2 ***

[01]	CONNECTION TEL CONNECTION ID TX TYPE	2 887 0166 Canon AUSTRALIA REGULAR TX
[03]	CONNECTION TEL CONNECTION ID TX TYPE	905 795 1111 Canon CANADA REGULAR TX
[04]	CONNECTION TEL CONNECTION ID TX TYPE	GROUP DIAL Canon GROUP 2
[05]	CONNECTION TEL CONNECTION ID TX TYPE	2 50921 Canon ITALIA REGULAR TX
[12]	CONNECTION TEL CONNECTION ID TX TYPE SUBADDRESS	1 432 2060 Canon OPTICS PSWD/SUBADD. 1323

IF YOU PRESS # IN STEP 7 (→ p. 6-19),
THE DESTINATIONS ARE LISTED IN
BUTTON ORDER (UNSORTED).

IF YOU PRESS * IN STEP 7 (→ p. 6-19),
THE DESTINATIONS ARE LISTED IN
ALPHABETICAL ORDER (SORTED).

■ CODED SPEED DIAL LIST 1

12/26/2003 17:23 FAX 123 4567 CANON 001

12/26/2003 17:23 FAX 123 4567 CANON 001

*** CODED SPEED DIAL LIST 1 ***

NO.	CONNECTION TEL	CONNECTION ID	TX TYPE
[* 00]	2131 1250	Canon DEUTSCH.	REGULAR TX
[* 02]	1 49 39 25 25	Canon FRANCE	REGULAR TX
[* 21]	GROUP DIAL	Canon GROUP 1	
[* 01]	03 3758 2111	Canon TOKYO	REGULAR TX
[* 03]	516p488 6700	Canon U.S.A.	REGULAR TX
[* 32]	81 773 3173	Canon UK	PSWD/SUBADD.

IF YOU PRESS # IN STEP 7 (→ p. 6-19),
THE DESTINATIONS ARE LISTED IN CODE
ORDER (UNSORTED).

IF YOU PRESS * IN STEP 7 (→ p. 6-19),
THE DESTINATIONS ARE LISTED IN
ALPHABETICAL ORDER (SORTED).

■ CODED SPEED DIAL LIST 2 (Detailed List)

12/26/2003 17:23 FAX 123 4567 CANON 001

12/26/2003 17:23 FAX 123 4567 CANON 001

*** CODED SPEED DIAL LIST 2 ***

[* 00]	CONNECTION TEL CONNECTION ID TX TYPE	2131 1250 Canon DEUTSCH. REGULAR TX
[* 02]	CONNECTION TEL CONNECTION ID TX TYPE	1 49 39 25 25 Canon FRANCE REGULAR TX
[* 21]	CONNECTION TEL CONNECTION ID	GROUP DIAL Canon GROUP 1
[* 01]	CONNECTION TEL CONNECTION ID TX TYPE	03 3758 2111 Canon TOKYO REGULAR TX
[* 03]	CONNECTION TEL CONNECTION ID TX TYPE	516p488 6700 Canon U.S.A. REGULAR TX
[* 32]	CONNECTION TEL CONNECTION ID TX TYPE SUBADDRESS	81 773 3173 Canon UK PSWD/SUBADD. 1323

IF YOU PRESS # IN STEP 7 (→ p. 6-19),
THE DESTINATIONS ARE LISTED IN CODE
ORDER (UNSORTED).

IF YOU PRESS * IN STEP 7 (→ p. 6-19),
THE DESTINATIONS ARE LISTED IN
ALPHABETICAL ORDER (SORTED).

■ GROUP DIAL LIST

12/26/2003 17:23 FAX 123 4567	CANON	001

*** GROUP DIAL LIST ***		

[03] Canon GROUP 2	[04] 2 50921	Canon ITALIA
	[* 00] 2131 1250	Canon DEUTSCH.
	[* 02] 1 49 39 25 25	Canon FRANCE
	[* 32] 81 773 3173	Canon UK
[* 21] Canon GROUP 1	[01] 905 795 1111	Canon CANADA
	[* 03] 516p488 6700	Canon U.S.A.

Chapter 7

Sending Faxes

This chapter describes all the necessary steps to send faxes and use the different sending features.

Preparing to Send a Fax	7-2
Documents You Can Fax	7-2
Setting the Scanning Resolution	7-2
Setting the Scanning Contrast.....	7-3
Dialing Methods.....	7-4
Sending Methods	7-5
Memory Sending	7-5
Manual Sending Via the Handset.....	7-6
Canceling Sending	7-8
Redialing When the Line is Busy	7-9
Manual Redialing.....	7-9
Canceling Manual Redialing.....	7-9
Automatic Redialing.....	7-9
What is Automatic Redialing?	7-9
Canceling Automatic Redialing	7-9
Setting the Options for Automatic Redialing	7-10
Sending the Same Document to Several Fax Numbers (Sequential Broadcasting)	7-12
Delayed Sending	7-15
Scanning a Document into Memory for Delayed Sending	7-15
Printing a Document Set for Delayed Sending.....	7-17
Deleting a Document Set for Delayed Sending.....	7-18

Preparing to Send a Fax

Documents You Can Fax

For information on the types of documents you can fax, their requirements, and details on loading documents, see Chapter 4.

Setting the Scanning Resolution

You can set the scanning resolution of documents you send. The higher the resolution the higher the output quality at the other end, but the slower the transmission speed. Adjust the scanning resolution according to the type of document you are sending.

If you are sending a document that requires some pages to be scanned at a different resolution from the others, you can change the resolution setting while the document is being scanned. However, please note that the new setting will only be effective from the next page scanned.

Follow this procedure to set the scanning resolution:

- 1** Press **Image Quality** repeatedly until the resolution setting you want is displayed.

FAX PHOTO

- You can select from the following:
 - FAX STANDARD
Suitable for most text-only documents.
 - FAX FINE
Suitable for fine-print documents.
 - FAX PHOTO
Suitable for documents that contain images such as photos. With this setting, areas of the document that contain photos are automatically scanned with 64 levels of gray, rather than just in black & white.
 - SUPER FINE
Suitable for documents that contain fine print and images. This setting is four times the resolution of the FAX STANDARD setting.

- 2** Continue with the operation you are performing.
 - If you do not proceed with any other operation, the LCD returns to standby mode after about 10 seconds.

Setting the Scanning Contrast

You can adjust the degree of contrast at which your document is scanned for sending and copying. Adjust according to how light or how dark your document is.

Follow this procedure to set the scanning contrast for sending and copying:

1 Press **Function**.

2 Press **Data Registration**.

DATA REGISTRATION

3 Press **Set** twice.

USER SETTINGS

DATE & TIME

4 Use ▼ or ▲ to select **SCAN CONTRAST**.

SCAN CONTRAST

5 Press **Set**.

STANDARD

6 Use ▼ or ▲ to select the scanning contrast you want.

- You can select from the following:
 - **STANDARD**
Adequate for most documents.
 - **DARKER**
Suitable for light documents.
 - **LIGHTER**
Suitable for dark documents.

7 Press **Set**.

OFFHOOK ALARM

8 Press **Stop/Reset** to return to standby mode.

12/26 FaxTel

Dialing Methods

There are several ways of dialing the fax number(s) you want to send to. They are as follows:

- **Regular Dialing**

Dial a fax number by using the numeric buttons, similar to dialing a telephone number.

- **One-Touch Speed Dialing**

Dial a fax number by pressing the one-touch speed dialing button (01 to 15) assigned to the fax number. For details on registering and using one-touch speed dialing, see pp. 6-3, 6-16.

- **Coded Speed Dialing**

Dial a fax number by pressing **Coded Dial** and entering the two-digit code (00 to 99) assigned to the fax number. For details on registering and using coded speed dialing, see pp. 6-8, 6-16.

- **Group Dialing**

Send a document to a predefined group of fax numbers registered for speed dialing. For details on registering groups and using group dialing, see pp. 6-13, 6-16.

- **Directory Dialing**

Look up the fax numbers you registered for one-touch speed dialing, coded speed dialing, and group dialing. For details on using directory dialing, see p. 6-18.

Sending Methods

This section explains the two main sending methods: *Memory sending* and *Manual sending via the handset*.

Memory Sending

Memory sending is a quick and easy way to send a document. As the machine scans the first page of a multipage document into its memory, it begins calling the other party and transmitting the information even as the remaining pages are being scanned.

Since your machine is multitasking, you can even scan a document into memory while performing other tasks.

Your machine has enough memory to store up to approximately 350 pages* (fewer if the document contains many graphics or particularly dense text).

Follow this procedure to send a document using memory sending:

1 Load the document, face down in the ADF (→ p. 4-3).

- To adjust the resolution and contrast, see pp. 7-2, 7-3.
- You may be unable to send if the memory used (shown in the LCD) is close to 100%. Use manual sending via the handset instead (→ p. 7-6).

MEMORY USED 0%
(Currently used memory)

DOCUMENT READY
(Standby to scan)

2 Dial the other party's fax number.

- For dialing methods, see p. 7-4.
- If you enter the wrong number, press **Stop/Reset**, then enter the correct number.
- If you are connected to a PBX and need to first dial an outside line access number ("9", for example), add a pause after that number by pressing **Pause** (→ p. 9-2).

TEL= 9p76xxxx

*Based on ITU-T No. 1 Chart, standard mode.

- 3** Press **Start/Copy** to begin scanning for sending, or if you used speed dialing, wait a few seconds for your machine to begin scanning automatically.
- If you do not want your machine to begin scanning automatically after a few seconds, disable the TIME OUT setting (→ p. 14-6).
 - To cancel sending once dialing has started, press **Stop/Reset** then ✕ (→ p. 7-8).
 - If the number you are calling is busy, your machine redials the number automatically after a few minutes (→ p. 7-9).



- You can have up to 20 different jobs waiting in memory to be sent.
- The document is automatically deleted from memory after sending. This occurs even if an error prevents complete transmission of the document.

Manual Sending Via the Handset

Manual sending via the handset allows you to talk to the other party before sending a document. This method is useful if the other party must manually activate their fax machine to receive a fax.

Follow this procedure to send a document using manual sending via the handset:

- 1** Make sure you have connected the handset or an extension telephone to your machine (→ p. 2-8).
- 2** Load the document, face down in the ADF (→ p. 4-3).
 - To adjust the resolution and contrast, see pp. 7-2, 7-3.
- 3** Press **Hook**.
 - You can also lift the handset instead of pressing **Hook**.

MEMORY USED 0%

(Currently used memory)

DOCUMENT READY

(Standby to scan)

TEL=

- 4** Dial the other party's fax/telephone number.
- For dialing methods, see p. 7-4.
 - If you make a mistake during dialing, press **Hook** or hang up the handset and start again from step 3.

TEL=	765xxxx
------	---------

■ **If you hear a high-pitched signal instead of a voice:**

- 5** Press **Start/Copy** to begin sending the document.
- If you picked up the handset to dial, press **Start/Copy** and hang up.

■ **If you hear a voice:**

- 5** Pick up the handset and start your conversation.
- If you pressed **Hook** instead of lifting the handset in step 3, you will hear the other party's voice but they will not be able to hear you through the speaker. Pick up the handset to talk to the other party.
- 6** When you are ready to send your document, ask the other party to press the start button on their fax machine.
- 7** When you hear the high-pitched signal of the other party's fax machine, press **Start/Copy** and hang up to begin sending the document.



Note

- If using the handset, be sure to hang up *after* you press **Start/Copy** on the machine, otherwise the call will be disconnected.
- Your machine will alert you by beeping if the handset is not hung up properly. Make sure the handset is seated properly in its cradle. If you do not want the machine to beep, disable the OFFHOOK ALARM setting (→ p. 14-4).

Canceling Sending

Follow this procedure if you want to stop sending a document before transmission is completed:

■ If you are sending a document using manual sending via the handset:

- 1 Press **Stop/Reset**.
 - The transmission is canceled.
 - The machine prints an ERROR TX REPORT (→ p. 11-4).

■ If you are sending a document using memory sending:

- 1 Press **Stop/Reset**.
 - Your machine asks you to confirm that you want to cancel sending.

CANCEL? *YES #NO

YES={*}	NO={#}
---------	--------

- 2 Press ***** to cancel sending.
 - Sending is not canceled until you press *****.
 - If you change your mind and want to continue sending, press **#**.
 - To cancel transmission of a document waiting to be sent (e.g. delayed sending, between redialings), you will have to delete it from memory (→ pp. 7-18, 9-8).
 - The machine prints an ERROR TX REPORT (→ p. 11-4).



When you cancel sending, you may need to open the operation panel to remove the document from the ADF (→ p. 13-2).

Redialing When the Line is Busy

There are two methods of redialing: *Manual redialing* and *Automatic redialing*. This section explains these two methods.

Manual Redialing

Press **Redial** to dial the last number you dialed with the numeric buttons. (This starts redialing regardless of whether automatic redialing is enabled.)

Canceling Manual Redialing

To cancel manual redialing, press **Stop/Reset**.

Automatic Redialing

What is Automatic Redialing?

When you are sending a document using memory sending (→ p. 7-5) and the other party's line is busy, your machine waits the specified time interval and then redials the number automatically. This is called *Automatic redialing*.

You will know that your machine is waiting to redial when AUTO REDIAL and the transaction number (TX/RX NO.) are displayed in the LCD.

The automatic redialing options allow you to customize the number of times your machine redials, as well as the time interval between redials. You can also disable automatic redialing if you prefer your machine not to do so.

If all automatic redialing attempts are unsuccessful, the machine cancels the transmission and prints an ERROR TX REPORT to notify you that the transmission was not completed (→ p. 11-4).

Canceling Automatic Redialing

Automatic redialing cannot be canceled with the **Stop/Reset** button while the machine is waiting to redial. You can either wait until your machine begins redialing and then follow the procedure below, or if you want to cancel while your machine is waiting to redial, you will have to delete the document from memory (→ p. 9-8).

Follow this procedure to cancel automatic redialing when your machine begins redialing:

- 1 Wait until your machine begins redialing.

DIALING

2 Press **Stop/Reset**.

- Your machine asks you to confirm that you want to cancel automatic redialing.

CANCEL? *YES #NO

YES={*} NO={#}

3 Press * to cancel redialing.

- Redialing is not canceled until you press *.
- If you change your mind and want to continue redialing, press #.
- The machine prints an ERROR TX REPORT (→ p. 11-4).

Setting the Options for Automatic Redialing

You can set the following options for automatic redialing:

- Whether the machine redials automatically (default: on).
- The number of times the machine attempts to redial (default: twice).
- The time interval between redialing attempts (default: two minutes).

Follow this procedure to adjust the automatic redialing options:

1 Press **Function**.

2 Press **Data Registration**.

DATA REGISTRATION

3 Press **Set**.

USER SETTINGS

4 Use ▼ or ▲ to select TX SETTINGS.

TX SETTINGS

5 Press **Set**.

ECM TX

6 Use ▼ or ▲ to select AUTO REDIAL.

AUTO REDIAL

7 Press **Set**.

ON

8 Use ▼ or ▲ to select the setting you want.

- You can select from the following:
 - ON
Enables automatic redialing.
 - OFF
Disables automatic redialing.

■ **If you selected OFF in step 8:**

9 Press **Set**.

TIME OUT

10 Press **Stop/Reset** to return to standby mode.

12/26 FaxTel

■ **If you selected ON in step 8:**

9 Press **Set** twice.

REDIAL TIMES

2TIMES

10 Use the numeric buttons to enter the number of times you want the machine to redial.

5TIMES

- You can select from 1 to 10 times.
- You can also use ▼ or ▲ to change the redial times.

11 Press **Set** twice.

REDIAL INTERVAL

2MIN.

12 Use the numeric buttons to enter the time interval between redials.

5MIN.

- You can select from 2 to 99 minutes.
- You can also use ▼ or ▲ to change the time interval.

13 Press **Set**.

TIME OUT

14 Press **Stop/Reset** to return to standby mode.

12/26 FaxTel

Sending the Same Document to Several Fax Numbers (Sequential Broadcasting)

This feature, also called *Sequential Broadcasting*, allows you to send the same document to several fax numbers in one operation. Simply load the document, enter the fax numbers, and the machine will then scan the document into its memory and send the document to all the fax numbers you entered, one after the other.

You can send the same document to as many as 116 fax numbers using this feature. Please note, however, that the fax numbers you enter must be registered for one-touch or coded speed dialing (→ Chapter 6). You will only be able to enter one fax number using regular dialing (e.g. with the numeric buttons or using the **Redial** button.)



If you frequently send documents to the same group of fax numbers, you can register these numbers for group dialing instead (→ p. 6-13). This will simplify dialing.

Follow this procedure to send the same document to several fax numbers:

- 1 Load the document, face down in the ADF (→ p. 4-3).
 - To adjust the resolution and contrast, see pp. 7-2, 7-3.
 - You may be unable to send if the memory used (shown in the LCD) is close to 100%. To free up space in the machine's memory: print, send, or delete any documents you no longer need to be stored in memory (→ p. 9-4).

MEMORY USED 0%
(Currently used memory)

DOCUMENT READY
(Standby to scan)

- 2 Enter up to 116 fax numbers using any of the following methods:

■ One-touch speed dialing:

Press the one-touch speed dialing button(s) you want.

O1=Canon EUROPA

■ Coded speed dialing:

Press **Coded Dial**, then use the numeric buttons to enter the two-digit code you want. Repeat for other codes.

*

* O1=Canon Inc.

- Be sure to press **Coded Dial** before each code.

■ Regular dialing:

Use the numeric buttons to enter the fax number you want, then press **Set**. You can also use the **Redial** button.

TEL= 2 88x xxxx

- You can only enter one fax number this way.

■ Directory dialing:

Press **Directory**, then use the numeric buttons to enter the first letter of the other party's name. Use ▼ or ▲ to find the name you want.

1ST LETT OF NAME

O4=Canon ITALIA



Note

- You can enter the fax numbers in any order.
- If you enter a wrong destination, press **Clear**, then enter the correct destination.
- You must enter the second destination within five seconds of entering the first one. All subsequent destinations must be entered within 10 seconds. If you wait longer than these times, your machine automatically begins scanning the document for sending. If you do not want your machine to begin scanning automatically after a few seconds, disable the TIME OUT setting (→ p. 14-6).
- To review the destinations entered, use ▼ or ▲ to scroll through the numbers.

3 Press **Start/Copy** to begin scanning for sending, or wait a few seconds for your machine to begin scanning automatically.

- Your machine will first send the document to the one-touch speed dialing destinations, then the coded speed dialing destinations, and finally to the destination dialed using regular dialing.
- If you do not want your machine to begin scanning automatically after a few seconds, disable the TIME OUT setting (→ p. 14-6).
- To cancel sending once dialing has started, press **Stop/Reset** then ✖. Sending to all destinations you specified in step 2 will be canceled. (You cannot cancel only one destination.)



Note

- If a number is busy, your machine will continue sending to the other destinations and then automatically redial the number that was busy.
- If the machine's memory becomes full while scanning your document, MEMORY FULL will appear in the LCD. If this happens, remove the remainder of the document from the ADF (you may need to open the operation panel to do so), then divide the document into several sections and send each section separately.

Delayed Sending

Your machine allows you to scan a document into its memory and send it automatically to as many as 116 fax numbers at a preset time within the next 24 hours. This is called *Delayed sending* or *Timer sending*. By using this feature, you can take advantage of lower long distance rates at night, for example.



To use delayed sending correctly, make sure the correct time is set on your machine (→ p. 3-6).

Scanning a Document into Memory for Delayed Sending

Follow this procedure to scan a document into the machine's memory for delayed sending:

- 1 Load the document, face down in the ADF (→ p. 4-3).
 - To adjust the resolution and contrast, see pp. 7-2, 7-3.
 - You may be unable to scan if the memory used (shown in the LCD) is close to 100%. To free up space in the machine's memory: print, send, or delete any documents you no longer need to be stored in memory (→ p. 9-4).

MEMORY USED 0%
(Currently used memory)

DOCUMENT READY
(Standby to scan)

- 2 Press **Function**.
- 3 Press **Delayed Transmission**.

REGISTER

- 4 Press **Set**.

SET TIME 15:00

- 5 Use the numeric buttons to enter the time at which you want to send the document.

SET TIME 22:30

- Use the 24-hour format for the time (e.g. 11:30 p.m. as 23:30), and precede single digits with a zero.

- 6 Press **Set**.

SELECT LOCATIONS

TEL=

- 7** Enter up to 116 fax numbers you want to send to using any of the following methods:

■ **One-touch speed dialing:**

Press the one-touch speed dialing button(s) you want.

01=Canon EUROPA

■ **Coded speed dialing:**

Press **Coded Dial**, then use the numeric buttons to enter the two-digit code you want. Repeat for other codes.

*

* 01=Canon Inc.

- Be sure to press **Coded Dial** before each code.

■ **Regular dialing:**

Use the numeric buttons to enter the fax number you want, then press

TEL= 2 88x xxxx

Set.

- You can only enter one fax number this way.

■ **Directory dialing:**

Press **Directory**, then use the numeric buttons to enter the first letter of the other party's name. Use ▼ or ▲ to find the name you want.

1ST LETT OF NAME

04=Canon ITALIA



Note

- If you enter the wrong destination, press **Clear**, then enter the correct destination.
- To review the destinations entered, use ▼ or ▲ to scroll through the numbers.

- 8** Press **Start/Copy** to begin scanning the document into the machine's memory.

- When the preset time is reached, your machine sends the document to the destination(s) you specified in step 7.



Note

- You can register up to 20 different delayed sending operations.
- If the machine's memory becomes full while scanning your document, MEMORY FULL will appear in the LCD. If this happens, you will not be able to send the document at a preset time. Remove the remainder of the document from the ADF (you may need to open the operation panel to do so).
- Since the machine is multitasking, you can perform other tasks even when your machine is set for delayed sending.

Printing a Document Set for Delayed Sending

Follow this procedure to print a document stored in memory for delayed sending:

1 Press **Function**.

2 Press **Delayed Transmission**.

REGISTER

3 Use ▼ or ▲ to select PRINT.

PRINT

4 Press **Set**.

TX/RX NO. 0001

5 Use ▼ or ▲ to select the transaction number (TX/RX NO.) of the document you want to print.

TX/RX NO. #0003

- If you are unsure of the transaction number (TX/RX NO.), print the DOC. MEMORY LIST (→ p. 9-4).
- A “#” before the transaction number (TX/RX NO.) indicates that that document is being sent at that moment and can therefore not be selected.
- Use ◀ or ▶ to display details of the transaction (e.g. destination).

6 Press **Set**.

1ST PG ONLY?

YES={*} NO={#}

7 Press * to print the first page only, or press # to print all pages of the document.

- The machine prints the document.

8 To continue printing other documents set for delayed sending, repeat the procedure from step 5.

-or-

Press **Stop/Reset** to return to standby mode.

12/26 FaxTel

Deleting a Document Set for Delayed Sending

Follow this procedure to delete a document stored in memory for delayed sending:

1 Press **Function**.

2 Press **Delayed Transmission**.

REGISTER

3 Use ▼ or ▲ to select **DELETE FILE**.

DELETE FILE

4 Press **Set**.

TX/RX NO. 0001

5 Use ▼ or ▲ to select the transaction number (TX/RX NO.) of the document you want to delete.

TX/RX NO. #0003

- If you are unsure of the transaction number (TX/RX NO.), print the DOC. MEMORY LIST (→ p. 9-4).
- A “#” before the transaction number (TX/RX NO.) indicates that that document is being sent at that moment. If you want to delete a document being sent, follow the instructions in the LCD.
- Use ◀ or ▶ to display details of the transaction (e.g. destination).

6 Press **Set**.

OK TO DELETE?

YES={*} NO={#}

7 Press * to delete the document.

- If you change your mind and want to keep the document in memory for delayed sending, press #.

ERASING END

8 To continue deleting other documents set for delayed sending, repeat the procedure from step 5.

-or-

Press **Stop/Reset** to return to standby mode.

12/26

FaxTel

Chapter 8

Receiving Faxes

This chapter explains how to select the best receive mode for your needs and how to receive faxes.

Receiving Methods	8-2
Receiving Both Faxes and Telephone Calls Automatically:	
Fax/Tel Mode.....	8-3
Setting Fax/Tel Mode.....	8-3
Setting the Options for Fax/Tel Mode.....	8-4
Receiving Faxes Manually: MANUAL MODE.....	8-6
Setting MANUAL MODE.....	8-6
Receiving a Fax Manually.....	8-6
Receiving Faxes Automatically: FAX ONLY MODE.....	8-8
Setting FAX ONLY MODE.....	8-8
Receiving With an Answering Machine: ANS.MACHINE MODE.....	8-9
Setting ANS.MACHINE MODE.....	8-9
Using the FAXPHONE With an Answering Machine.....	8-9
Receiving With the Distinctive Ring Pattern Detection	
Feature: DRPD.....	8-10
Setting DRPD.....	8-10
Receiving While Performing Other Tasks	8-12
Receiving Faxes in Memory When a Problem Occurs	8-12
Canceling Receiving	8-12

Receiving Methods

Your machine provides you with several modes for receiving faxes. To determine which mode best suits your requirements, refer to the table below:

Receive Mode	Main Use	Operation	Requirements	Details
Fax/Tel Mode	Fax/Tel	The machine automatically switches between fax and voice calls. It receives faxes automatically and rings for voice calls.	Handset or the extension telephone connected to your machine.	p. 8-3
MANUAL MODE	Tel	The machine rings for every call, whether a fax call or a voice call. For a fax call, you have to manually activate reception of a fax.	Handset or the extension telephone connected to your machine.	p. 8-6
FAX ONLY MODE	Fax	The machine answers all calls as fax calls. It receives faxes automatically and disconnects voice calls.	Separate telephone line for fax use only.	p. 8-8
ANS.MACHINE MODE	Fax/Tel	The machine receives documents automatically and the answering machine records voice messages.	Answering machine connected to your machine.	p. 8-9
DRPD	Fax/Tel	The machine rings differently depending on whether a call is a fax or voice call.	Subscription to a DRPD service. Handset or the extension telephone connected to your machine.	p. 8-10

Once you have decided which mode is suitable for your needs, set the mode as described in this chapter. You can change the mode at any time.

Receiving Both Faxes and Telephone Calls Automatically: Fax/Tel Mode

Set this mode if you only have one telephone line for fax and telephone use and want your machine to automatically switch between fax and voice calls.

Setting Fax/Tel Mode

Your machine is factory-set to Fax/Tel Mode. If you have not changed the receive mode to FAX ONLY MODE or DRPD, simply follow this procedure:

- 1** Press **Function**, then **Receive Mode**. Fax/Tel Mode
- 2** Press **▼** or **▲** to select Fax/Tel Mode.
- 3** Press **Set**. 12/26 FaxTel
 - The LCD changes to this display:

If Fax/Tel Mode does not appear in the LCD, follow this procedure to set FAX/TEL AUTO SW (Fax/Tel Mode):

- 1** Press **Function**.
- 2** Press **Data Registration**. DATA REGISTRATION
- 3** Press **Set**. USER SETTINGS
- 4** Use **▼** or **▲** to select RX SETTINGS. RX SETTINGS
- 5** Press **Set**. ECM RX
- 6** Use **▼** or **▲** to select RX MODE. RX MODE
- 7** Press **Set**. FAX ONLY MODE
- 8** Use **▼** or **▲** to select FAX/TEL AUTO SW. FAX/TEL AUTO SW
- 9** Press **Set**. RING START TIME
 - To set the options for FAX/TEL AUTO SW (Fax/Tel Mode), see the following pages.
- 10** Press **Stop/Reset** to return to standby mode. 12/26 FaxTel
- 11** Confirm that FaxTel is displayed in the LCD. 12/26 FaxTel
 - If FaxTel is not displayed, follow steps 1 to 3 on top of this page.

Setting the Options for Fax/Tel Mode

If you set Fax/Tel Mode, you can control precisely how the machine handles incoming calls by adjusting the following settings:

- RING START TIME setting: Adjust the time the machine takes to check whether a call is from a fax machine or from a telephone (default: 8 seconds).
- F/T RING TIME setting: Adjust the length of time the machine rings when the call is from a telephone (default: 15 seconds).
- DEFAULT ACTION setting: Set whether the machine switches to receive mode or disconnects the call after the ring time set in F/T RING TIME has elapsed (default: switches to receive mode).

■ What Happens When Fax/Tel Mode is Selected

When the machine receives a call, it responds according to the type of call as follows:

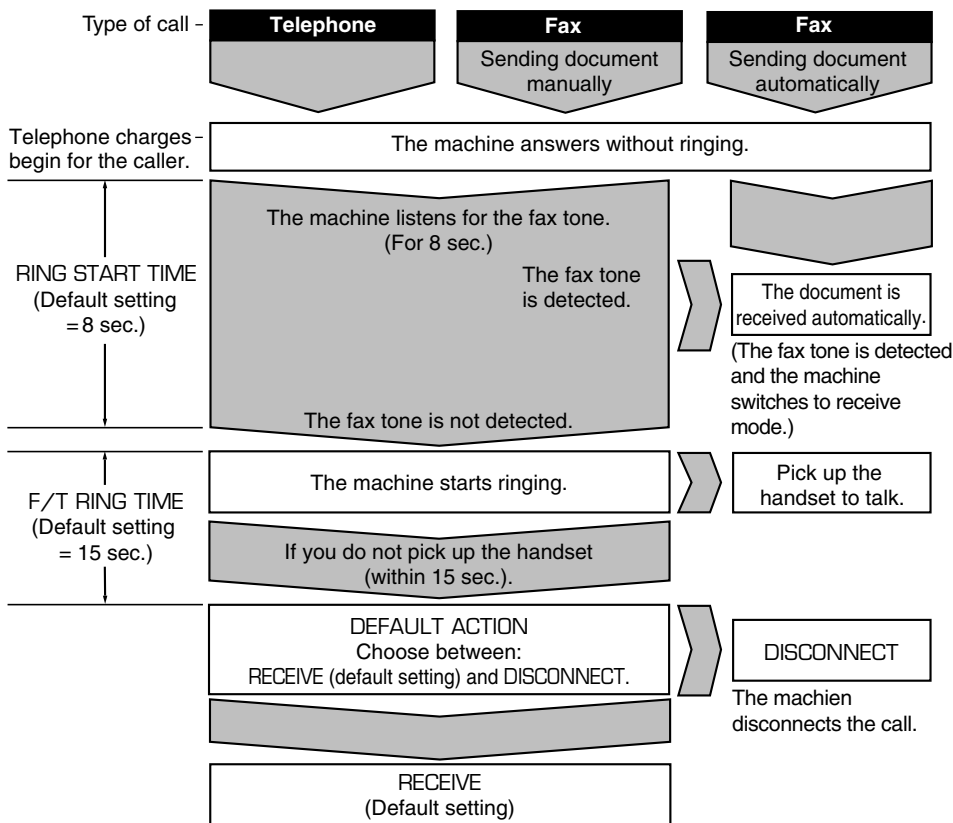

Not all fax machines are capable of sending the fax tone. If this is the case, set the DEFAULT ACTION setting to RECEIVE so that the machine switches to receive mode automatically and starts receiving the document. If no document comes in, it disconnects the call after approximately 40 seconds.

Follow this procedure to set the Fax/Tel Mode options:

1 Follow steps 1 to 9 on page 8-3.

RING START TIME

2 Press **Set**.

8SEC

3 Use the numeric buttons to enter the RING START TIME duration.

9SEC

- You can select from 0 to 30 seconds.
- See the previous page for details on this setting.
- You can also use ▼ or ▲ to change the time interval.

4 Press **Set** twice.

F/T RING TIME

15SEC

5 Use the numeric buttons to enter the F/T RING TIME duration.

30SEC

- You can select from 10 to 45 seconds.
- See the previous page for details on this setting.
- You can also use ▼ or ▲ to change the time interval.

6 Press **Set** twice.

DEFAULT ACTION

RECEIVE

7 Use ▼ or ▲ to select the DEFAULT ACTION setting you want.

- You can select from the following:
 - RECEIVE (Switch to receive mode)
 - DISCONNECT (Disconnect the call)
- See the previous page for details on this setting.

8 Press **Set**.

INCOMING RING

9 Press **Stop/Reset** to return to standby mode.

12/26 FaxTel

Receiving Faxes Manually: MANUAL MODE

Set this mode if you only have one telephone line that you use mainly for voice calls, and only occasionally to receive faxes.

You can activate reception directly from your machine, or if your telephone is located away from your machine, you can dial the remote receiving ID on the telephone to activate reception (this is called *Remote reception*).

Setting MANUAL MODE

Follow this procedure to set the receive mode to MANUAL MODE:

- 1 Press **Function**, then **Receive Mode**.

MANUAL MODE

- 2 Press ▼ or ▲ to select MANUAL MODE.

- 3 Press **Set**.

- The LCD changes to this display:

12/26	Manual
-------	--------

Receiving a Fax Manually

Follow this procedure to receive a fax manually:

- 1 Make sure Manual is displayed in the LCD.

12/26	Manual
-------	--------

- 2 Make sure you have connected the handset or extension telephone to your machine (→ p. 2-8).

- 3 When you hear the handset or extension telephone ring, pick up the handset.

■ If you hear a long beep tone or silence:

- 4 Someone is trying to send you a fax. Press **Start/Copy** on your machine and hang up to begin receiving the document.

- If you are using the extension telephone and it is located away from your machine, dial 25 (the default remote receiving ID) on your telephone and hang up.

■ If you hear a voice:

- 4 Start your conversation. If the caller wants to send a fax after talking to you, ask them to press the start button on their fax machine.
- 5 When you hear a long beep, press **Start/Copy** on your machine and hang up to begin receiving the document.
 - If you are using the extension telephone and it is located away from your machine, dial 25 (the default remote receiving ID) on your telephone and hang up.



- If using the handset, be sure to hang up *after* you press **Start/Copy** on the machine, otherwise the call will be disconnected.
- Your machine will alert you by beeping if the handset is not hung up properly. Make sure the handset is seated properly in its cradle. If you do not want the machine to beep, disable the OFFHOOK ALARM setting (→ p. 14-4).
- If you cannot activate reception from the extension telephone, check that the REMOTE RX setting is enabled (→ p. 14-7).
- You can change the remote receiving ID (→ REMOTE RX ID, p. 14-7), or disable remote receiving (→ REMOTE RX, p. 14-7).
- If you have an answering machine connected to your machine that can carry out remote-control operations (controlling your answering machine from a remote telephone), the security code for this function may be the same as the remote receiving ID of your machine. If this is the case, make sure you change the machine's remote receiving ID to make it distinct from the answering machine's security code (→ REMOTE RX ID, p. 14-7).

Receiving Faxes Automatically: FAX ONLY MODE

If you have a separate telephone line for fax use only, connect your machine to this line and set FAX ONLY MODE. Your machine will answer all calls as fax calls.

Setting FAX ONLY MODE

Follow this procedure to set the receive mode to FAX ONLY MODE:

- 1** Press **Function**.
- 2** Press **Data Registration**. DATA REGISTRATION
- 3** Press **Set**. USER SETTINGS
- 4** Use ▼ or ▲ to select RX SETTINGS. RX SETTINGS
- 5** Press **Set**. ECM RX
- 6** Use ▼ or ▲ to select RX MODE. RX MODE
- 7** Press **Set**. FAX/TEL AUTO SW
- 8** Use ▼ or ▲ to select FAX ONLY MODE. FAX ONLY MODE
- 9** Press **Set**. INCOMING RING
- 10** Press **Stop/Reset** to return to standby mode. 12/26 FaxOnly
- 11** Confirm that FaxOnly is displayed in the LCD.
 - If FaxOnly is not displayed, follow steps 1 to 3 on top of p. 8-3.12/26 FaxOnly

The machine treats all incoming calls as fax calls. It receives faxes automatically and disconnects any voice calls.



The machine does not ring when it receives a fax call. If you want to be alerted when a fax call is received, connect the handset or an extension telephone to the machine, and enable the INCOMING RING setting (→ p. 14-7). You can also select the number of rings before the machine answers (→ RING COUNT, p. 14-7).

Receiving With an Answering Machine: ANS.MACHINE MODE

Connecting an answering machine to the machine allows you to receive faxes and telephone messages while you are out.

In ANS.MACHINE MODE, the machine allows the answering machine to answer incoming calls, then listens for the fax tone and automatically receives the fax if it detects this tone.

Setting ANS.MACHINE MODE



For this mode, you need to connect an answering machine or a telephone with an answering machine to your machine (→ p. 2-8).

Follow this procedure to set the receive mode to ANS.MACHINE MODE:

1 Press **Function**, then **Receive Mode**.

ANS.MACHINE MODE

2 Press **▼** or **▲** to select ANS.MACHINE MODE.

3 Press **Set**.

- The LCD changes to this display:

12/26 AnsMode

Using the FAXPHONE With an Answering Machine

Follow these guidelines when using the machine with an answering machine:

- Set the answering machine to answer on the first or second ring.
- When recording the outgoing message on the answering machine, the entire message must be no longer than 15 seconds.

For example: “Hello. I can’t answer the phone right now, but please leave a message after the beep. Thank you.”

Receiving With the Distinctive Ring Pattern Detection Feature: DRPD

- **Choose this mode if:**

- you only have one telephone line for both fax and telephone use.
- you want to receive faxes automatically as well as voice calls.
- you have subscribed to a DRPD (Distinctive Ring Pattern Detection) service with your telephone company. This service assigns two or more telephone numbers with distinctive ring patterns to a single telephone line, allowing you to have both a fax number(s) and a telephone number(s) using only one telephone line. Your machine will automatically monitor incoming calls and based on the ring pattern, will let you know if the call is a fax or voice call. Contact your telephone company for more information on this service.

- **You will need to:**

- subscribe to a DRP service offered by some telephone companies.
- connect the handset to your machine (→ *Set-Up Instructions*).

- **When you receive a fax call:** The machine will ring according to the ring pattern you have chosen and receive the fax automatically.

- **When you receive a voice call:** The machine will ring according to the ring pattern you have chosen. Pick up the handset to answer the call.

Setting DRPD

Your telephone company will assign a distinctive ring pattern to each number when you order the DRP service.

Follow this procedure to set the fax ring pattern that matches the pattern assigned by the telephone company.

1 Press **Function**.

2 Press **Data Registration**.

DATA REGISTRATION

3 Press **Set**.

USER SETTINGS

4 Use ▼ or ▲ to select RX SETTINGS.

RX SETTINGS

5 Press **Set**.

ECM RX

6 Use ▼ or ▲ to select RX MODE.

RX MODE

7 Press **Set**.

FAX/TEL AUTO SW

8 Use ▼ or ▲ to select DRPD.

DRPD

9 Press **Set**.

DRPD:SELECT FAX

10 Press **Set**.

NORMAL RING

11 Use ▼ or ▲ to select the type of ring pattern that your telephone company assigned to your fax number.

• You can select from the following:

- NORMAL RING
- DOUBLE RING
- SHORT-SHORT-LONG
- SHORT-LONG-SHORT
- OTHER RING TYPE

12 Press **Set**.

13 Press **Stop/Reset** to return to standby mode.

12/26 DRPD

Receiving While Performing Other Tasks

The machine is a multitasking device so it can receive faxes and voice calls while you are performing other tasks.

If your machine cannot print a received fax because it is performing another task that prevents it from doing so, it will receive the fax in memory. Then, as soon as it completes the other task, your machine automatically prints the received fax from memory.

Receiving Faxes in Memory When a Problem Occurs

If your machine encounters a problem when receiving a fax, it automatically stores the unprinted pages of the fax in memory. It then displays REC'D IN MEMORY as well as one or more messages in the LCD. For an explanation of the message(s) and details on the action to take, see p. 13-8.



Note

- The machine's memory can store up to approximately 350 pages.*
- You can set the machine so that it does not store faxes in memory if a problem occurs during reception (→ MEMORY RX, p. 14-7).
- Once the problem is solved and the machine prints the received fax, it will delete the fax from memory.
- If the machine's memory becomes full while receiving a fax in memory, you will not be able to receive the remaining pages. Contact the other party and ask them to resend the remainder of the fax.

Canceling Receiving

Follow this procedure if you want to stop receiving a fax before reception is completed:

1 Press **Stop/Reset**.

- Your machine asks you to confirm that you want to cancel receiving.

CANCEL? *YES #NO

YES=[*] NO=[#]

2 Press ***** to cancel receiving.

- Receiving is not canceled until you press *****.
- If you change your mind and want to continue receiving, press **#**.

TX/RX CANCELLED

TX/RX NO. 5003

*Based on ITU-T No. 1 Chart, standard mode.

Chapter 9

Special Features

This chapter describes the special dialing methods and explains other useful features of your machine.

Special Dialing	9-2
Dialing Through a Switchboard	9-2
Entering Pauses in a Fax/Telephone Number	9-2
Switching Temporarily to Tone Dialing	9-3
Documents Stored in Memory	9-4
Printing a List of Documents Stored in Memory	9-4
Printing a Document Stored in Memory	9-5
Sending a Document Stored in Memory	9-6
Deleting a Document Stored in Memory	9-8
Polling	9-9
What is Polling?	9-9
Polling Receiving	9-9
Polling Another Fax Machine	9-9
Canceling Polling Receiving	9-11
Polling Sending	9-12
Setting Up the Polling Box	9-12
Scanning a Document into the Polling Box	9-15
Changing or Deleting the Polling Box Settings	9-15
Restricting Reception	9-17

Special Dialing

Dialing Through a Switchboard

A PBX (Private Branch Exchange) is an on-site telephone switchboard. If your machine is connected through a PBX or other telephone switching system, you will need to dial the outside line access number first, and then the number of the party you are calling.

Entering Pauses in a Fax/Telephone Number

You may need to enter pauses in a fax/telephone number in the following situations:

- When you dial or register an overseas number. The length and position of the pause depends on the telephone system of your country.
- When your machine is connected to a switchboard.

Follow this procedure to enter pauses when registering a number for speed dialing:

- 1** When you come to the step that requires you to enter the fax/telephone number, use the numeric buttons to enter the number up to where a pause is necessary.

TEL=011_

- To correct a mistake in the number, press **◀** to delete the rightmost digit. Alternatively, press **Clear** to delete the entire number.

- 2** Press **Pause** to enter a pause.

TEL=011P_

- A pause entered within a number (P) is two seconds long.
- For a longer pause, press **Pause** again for another two-second pause. Alternatively, you can change the length of the pause (→ MID PAUSE SET, p. 14-6).

- 3** Continue entering the rest of the fax/telephone number with the numeric buttons.

TEL=011pxxxxxx_

- If you enter the wrong number, press **Clear** and start again from step 1.

- 4** To enter a pause at the end of the number, press **Pause**.

TEL=011pxxxxxxP

- A pause at the end of a number (P) is fixed to ten seconds.

- 5** Continue with the operation you are performing.

Switching Temporarily to Tone Dialing

Many information services for banks, airline reservations, hotel reservations, etc., require tone dialing for their services. If your machine is set for pulse dialing (→ p. 3-8), follow this procedure to set your machine temporarily for tone dialing:

1 Press **Hook**.

- You can also lift the handset instead of pressing **Hook**.

TEL=

2 Use the numeric buttons to dial the telephone number of the information service.

- Your machine connects using the pulses required by your telephone line.

TEL= 765xxxx

3 When the recorded message of the information service answers, press ✱ (**Tone**) to switch to tone dialing.

- When ✱ (**Tone**) is pressed, (T) is displayed in the LCD.
- If you pressed **Hook** in step 1, you can pick up the handset if you need to talk to the other party.

TEL= 765xxxxT

4 Use the numeric buttons to enter the numbers requested by the information service.

- Numbers entered after pressing ✱ (**Tone**) will be dialed using tone dialing.

TEL= 765xxxxT✱34

5 When you have finished, press **Hook** to disconnect the call.

- If you used the handset, hang up to disconnect the call.
- Tone dialing is canceled when you disconnect the call.

Documents Stored in Memory

This section describes how to perform different operations with documents stored in memory. You will find instructions for printing a list of documents in memory, as well as procedures for printing, sending, and deleting documents stored in memory.

Printing a List of Documents Stored in Memory

The machine can print a list of documents stored in memory, along with the transaction number (TX/RX NO.) of each document. Once you know the transaction number of a document in memory, you can print it, send it, or delete it. These procedures are described on the following pages.

Follow this procedure to print a list of documents stored in memory:

1 Press **Function**.

2 Press **Memory Reference**.

DOC. MEMORY LIST

3 Press **Set**.

- The machine prints the DOC. MEMORY LIST.

PRINTING REPORT

12/26/2003 21:53 FAX 123 4567		CANON		001	
***** *** DOC. MEMORY LIST *** *****					
TX/RX NO	MODE	CONNECTION TEL/ID	PGS.	SET TIME	ST. TIME
0046	TRANSMIT	[* 01] Canon TOKYO	3	12/26 21:24	
0047	B'CAST	[01] Canon CANADA	1	12/26 21:36	
		[* 02] Canon FRANCE			
0048	DEL SQ BDCST	[04] Canon ITALIA	1	12/26 21:39	23:00
		[* 03] Canon U.S.A.			23:00
0049	DELAYED TX	[05] Canon OPTICS	2	12/26 21:45	23:00
0050	B'CAST	[03] Canon GROUP 2	1	12/26 21:49	

Printing a Document Stored in Memory

Follow this procedure to print a document stored in memory:



When you print a document stored in memory using the following procedure, the print is reduced to 90% of the original.

1 Press **Function**.

2 Press **Memory Reference**.

DOC. MEMORY LIST

3 Use ▼ or ▲ to select **PRINT DOCUMENT**.

PRINT DOCUMENT

4 Press **Set**.

TX/RX NO. 0001

5 Use ▼ or ▲ to select the transaction number (TX/RX NO.) of the document you want to print.

TX/RX NO. #0003

- If you are unsure of the transaction number (TX/RX NO.), print the DOC. MEMORY LIST (→ p. 9-4).
- A “#” before the transaction number (TX/RX NO.) indicates that that document is being sent at that moment and can therefore not be selected.
- Use ◀ or ▶ to display details of the transaction (e.g. destination).

6 Press **Set**.

1ST PG ONLY?

YES={*} NO={#}

7 Press * to print the first page only, or press # to print all pages of the document.

- The machine prints the document.

8 To continue printing other documents in memory, repeat the procedure from step 5.

-or-

Press **Stop/Reset** to return to standby mode.

12/26 FaxTel

Sending a Document Stored in Memory

Follow this procedure to send a document received in memory or stored in the polling box (for polling sending):

1 Press **Function**.

2 Press **Memory Reference**.

DOC. MEMORY LIST

3 Use ▼ or ▲ to select RESEND DOCUMENT.

RESEND DOCUMENT

4 Press **Set**.

TX/RX NO. 0001

5 Use ▼ or ▲ to select the transaction number (TX/RX NO.) of the document you want to send.

TX/RX NO. #5003

- If you are unsure of the transaction number (TX/RX NO.), print the DOC. MEMORY LIST (→ p. 9-4).
- A “#” before the transaction number (TX/RX NO.) indicates that that document is being sent or printed at that moment, and can therefore not be selected.
- Use ◀ or ▶ to display details of the transaction (e.g. destination).

6 Press **Set**.

- If you are sending a document stored in the polling box (for polling sending), enter the password (when you have set a password), then press **Set**.

SELECT LOCATIONS

TEL=

7 Enter up to 116 fax numbers you want to send to using any of the following methods:

■ One-touch speed dialing:

Press the one-touch speed dialing button(s) you want.

01=Canon EUROPA

■ Coded speed dialing:

Press **Coded Dial**, then use the numeric buttons to enter the two-digit code you want. Repeat for other codes.

*

* 01=Canon Inc.

- Be sure to press **Coded Dial** before each code.

■ Regular dialing:

Use the numeric buttons to enter the fax number you want, then press **Set**.

- You can only enter one fax number this way.
- To correct a mistake in the number, press ◀ to delete the rightmost digit. Alternatively, press **Clear** to delete the entire number.

TEL=	2 88x xxxx
------	------------

■ Directory dialing:

Press **Directory**, then use the numeric buttons to enter the first letter of the other party's name. Use ▼ or ▲ to find the name you want.

1ST LETT OF NAME

04=Canon ITALIA



Note

- If you enter a wrong destination, press **Clear**, then enter the correct destination.
- To review the destinations entered, use ▼ or ▲ to scroll through the numbers.

8 Press **Set** to begin sending.

- To cancel sending once dialing has started, press **Stop/Reset** then ✖. Sending to all the destinations you specified in step 7 will be canceled. (You cannot cancel only one destination.)

Deleting a Document Stored in Memory

Follow this procedure to delete a document stored in memory:

1 Press **Function**.

2 Press **Memory Reference**.

DOC. MEMORY LIST

3 Use ▼ or ▲ to select **DELETE DOCUMENT**.

DELETE DOCUMENT

4 Press **Set**.

TX/RX NO. 0001

5 Use ▼ or ▲ to select the transaction number (TX/RX NO.) of the document you want to delete.

TX/RX NO. #0003

- If you are unsure of the transaction number (TX/RX NO.), print the DOC. MEMORY LIST (→ p. 9-4).
- A “#” before the transaction number (TX/RX NO.) indicates that that document is being sent at that moment. If you want to delete a document being sent, follow the instructions in the LCD.
- Use ◀ or ▶ to display details of the transaction (e.g. destination).

6 Press **Set**.

- If you are deleting a document stored in the polling box (→ p. 9-15), enter the password that restricts access to the polling box settings, then press **Set**.

OK TO DELETE?

YES={*} NO={#}

7 Press ✖ to delete the document.

- If you change your mind and want to keep the document in memory, press #.

ERASING END

8 To continue deleting other documents in memory, repeat the procedure from step 5.

-or-

Press **Stop/Reset** to return to standby mode.

12/26 FaxTel

Polling

What is Polling?

In normal faxing, a fax machine sends a document to another fax machine. With polling, a fax machine calls another fax machine and requests that a document be sent to it; in other words, it “polls” that fax machine.

Your machine has the capability of functioning in both roles; it can poll another fax machine to retrieve a document from it (polling receiving), or it can hold a document in its polling box so that other fax machines can poll your machine and retrieve your document (polling sending).

Polling Receiving

In polling receiving, your machine calls another fax machine and requests it sends the document it is holding.

You may find polling receiving convenient in the following situations:

- When you want to retrieve a document from an establishment, such as a bank or information service.
- When you want to retrieve a document from another fax machine at your convenience.
- When you want to bear the transmission cost of receiving a document.

Polling Another Fax Machine

Before polling another fax machine, be sure to read the following:

- The machine can only poll fax machines that support polling.
- The document you want to retrieve must be ready to be polled on the other party's fax machine. If necessary, call the other party to check.
- Call the other party and check if you require a subaddress and/or password to retrieve the document from their fax machine. If you do, take note of them and register them together with the fax number for speed dialing (→ Chapter 6). You can only poll with a subaddress/password by using speed dialing. If you do not require a subaddress/password, you can retrieve the document without having to enter these numbers.
- If the other party is using a Canon fax machine and their machine does not support subaddress/password transactions, ask them to set the polling ID on their fax machine to 255 or 11111111 binary.
- You can poll several fax machines in one operation. Each polling operation can retrieve documents from as many as 116 fax numbers.
- The subaddress/password must be an ITU-T-standard subaddress/password.

Follow this procedure to poll one or several fax machine(s):

1 Press **Function**.

2 Press **Polling**.

POLLING TX

3 Use ▼ or ▲ to select POLLING RX.

POLLING RX

4 Press **Set**.

TEL=

5 Enter up to 116 fax numbers you want to poll using any of the following methods:

■ **One-touch speed dialing:**

Press the one-touch speed dialing button(s) you want.

O1=Canon EUROPA

■ **Coded speed dialing:**

Press **Coded Dial**, then use the numeric buttons to enter the two-digit code you want. Repeat for other codes.

*

- Be sure to press **Coded Dial** before each code.

* O1=Canon Inc.

■ **Regular dialing:**

Use the numeric buttons to enter the fax number you want, then press **Set**.

TEL= 2 88x xxxx

- You can only enter one fax number this way.
- To correct a mistake in the number, press ◀ to delete the rightmost digit. Alternatively, press **Clear** to delete the entire number.

■ **Directory dialing:**

Press **Directory**, then use the numeric buttons to enter the first letter of the other party's name. Use ▼ or ▲ to find the name you want.

1ST LETT OF NAME

O4=Canon ITALIA



Note

- If you enter a wrong destination, press **Clear**, then enter the correct destination.
- You cannot enter a subaddress/password with regular dialing. If you need to enter a subaddress/password for polling, register them together with the fax number for speed dialing (→ Chapter 6).
- To review the destinations entered, use ▼ or ▲ to scroll through the numbers.

- 6** Press **Start/Copy** to begin polling the fax machine(s).

Canceling Polling Receiving

To cancel polling receiving, follow the same procedure as for canceling receiving (→ p. 8-12).

Polling Sending

In polling sending, your machine holds a document in its polling box so that other fax machines can retrieve it.

You may find polling sending convenient in the following situations:

- A company department might store a document in the machine so that other departments can retrieve it if they require that document.
- When you want the other party to retrieve a document from your machine at their convenience.
- When you want the other party to bear the transmission cost of receiving a document from your machine.

Setting Up the Polling Box

This section explains how to set up the machine's polling box so that you can scan a document into it for other fax machines to retrieve it.

Before setting up the polling box, be sure to read the following:

- You can set an ITU-T-standard password for the polling box to restrict being polled only by fax machines that have this exact password (see the instructions that follow). Make sure you contact the other party to inform them of your password. Do not set a password if the other party's fax machine does not support password transactions.
- Your machine can be set to hold the document in its polling box until it is polled by one fax machine, or it can be set to continue to hold it so that several fax machines can retrieve the document (see below for details).

Follow this procedure to set up the polling box:

1 Press **Function**.

2 Press **Data Registration**.

DATA REGISTRATION

3 Press **Set**.

USER SETTINGS

4 Use ▼ or ▲ to select **POLLING BOX**.

POLLING BOX

5 Press **Set** three times.

SETUP FILE

FILE NAME

_ :A

- 6** Use the numeric buttons to enter a name for the polling box (max. 24 characters, including spaces).

- If you are unsure how to enter characters, see p. 3-2.

Canon Dpt.1_ :1

- 7** Press **Set** twice.

PASSWORD

PASSWORD _

- 8** Use the numeric buttons to enter a four-digit password.

- This password prevents unauthorized access to the polling box settings. You will need to enter this password whenever you want to change or delete the polling box settings. If you do not want to enter a password, ignore this step.

PASSWORD 1234

- 9** Press **Set** twice.

TX PASSWORD

- 10** Use the numeric buttons to enter a TX password (max. 20 digits, including *, #, and spaces).

- The fax machine(s) that will be polling your machine must have this password registered to be able to retrieve the document.
- If you do not want to register a password, ignore this step.

#123456

- 11** Press **Set** twice.

ERASE AFTER TX

ON

12 Use ▼ or ▲ to select if the document remains in the machine's memory after it is polled.

- You can select from the following:
 - ON
The document in the polling box is deleted after it is retrieved by one fax machine.
 - OFF
The document in the polling box remains in the polling box so that it can be retrieved by an unlimited number of fax machines.

13 Press **Set**.

CHANGE DATA

14 Press **Stop/Reset** to return to standby mode.

12/26 FaxTel

Once you have set up the polling box, you are ready to scan into it the document you want other fax machines to retrieve.

Scanning a Document into the Polling Box

Follow this procedure to store a document in the polling box so that other fax machines can retrieve it:



You need to set up the polling box before you can scan a document into the polling box (→ p. 9-12).

- 1** Load the document, face down in the ADF (→ p. 4-3).
 - To adjust the resolution and contrast, see pp. 7-2, 7-3.
 - You may be unable to scan if the memory used (shown in the LCD) is close to 100%. To free up space in the machine's memory: print, send, or delete any documents you no longer need to be stored in memory (→ p. 9-4).

MEMORY USED 0%

(Currently used memory)

DOCUMENT READY

(Standby to scan)

- 2** Press **Function**.

- 3** Press **Polling**.

POLLING TX

- 4** Press **Set**.

- The machine scans the document into the polling box.

When another fax machine polls your machine, the following conditions apply:

- If you registered a password for the polling box, the other party's fax machine must request the document with this exact same password.
- If you have not registered a password for the polling box, but the other fax machine requests the document from your machine with a password, the document cannot be retrieved.

Changing or Deleting the Polling Box Settings

Follow this procedure to change or delete the polling box settings:



You will be unable to delete the polling box settings if you have scanned a document into the polling box (see above). Delete the document from memory first before following the procedure below (→ p. 9-8).

- 1** Press **Function**.

2 Press **Data Registration**.

DATA REGISTRATION

3 Press **Set**.

USER SETTINGS

4 Use ▼ or ▲ to select POLLING BOX.

POLLING BOX

5 Press **Set**.

SETUP FILE

6 Use ▼ or ▲ to select the setting you want.

- You can select from the following:
 - CHANGE DATA
 - DELETE FILE

■ If you selected CHANGE DATA in step 6:

7 Press **Set**.

- If you registered a password to prevent unauthorized access to the polling box settings, use the numeric buttons to enter it, then press **Set**.

FILE NAME

8 Use ▼ or ▲ to select the setting you want and press **Set**.

- You can select from the following:
 - FILE NAME
 - PASSWORD
 - TX PASSWORD
 - ERASE AFTER TX

Canon Dpt.1 :A

9 To change the polling box settings, follow the procedure from step 6 on p. 9-13.

■ If you selected DELETE FILE in step 6:

7 Press **Set**.

- If you registered a password to prevent unauthorized access to the polling box settings, use the numeric buttons to enter it, then press **Set**.
- The polling box settings are deleted.

FILE DELETED

SYSTEM SETTINGS

8 Press **Stop/Reset** to return to standby mode.

12/26 FaxTel

Restricting Reception

By enabling this feature, you can restrict reception of faxes to only the numbers registered for speed dialing on your machine. This feature is useful to prevent reception of unsolicited faxes (e.g. junk mail).

Follow this procedure to enable or disable receiving restriction:

1 Press **Function**.

2 Press **Data Registration**.

DATA REGISTRATION

3 Press **Set**.

USER SETTINGS

4 Use ▼ or ▲ to select **SYSTEM SETTINGS**.

SYSTEM SETTINGS

5 Press **Set** twice.

RX RESTRICTION

OFF

6 Use ▼ or ▲ to select the setting you want.

- You can select from the following:
 - ON (Enable restriction)
 - OFF (Disable restriction)

■ **If you selected ON in step 6:**

7 Press **Set** twice.

RX CONDITION

REGISTERED SENDR

8 Use ▼ or ▲ to select the restriction type setting you want.

- You can select from the following:
 - REGISTERED SENDR
To allow reception from the numbers registered for speed dialing.
 - WITH SENDER INFO
To allow reception only when the caller gives its telephone number.

9 Press **Set**.

DATE SETUP

10 Press **Stop/Reset** to return to the standby mode.

12/26

FaxTel

■ **If you selected OFF in step 6:**

9 Press **Set**.

DATE SETUP

10 Press **Stop/Reset** to return to standby mode.

12/26 FaxTel

Chapter 10

Copying

This chapter describes how to make copies with your machine.

Documents You Can Copy10-2
Making Copies10-2

Copying

Documents You Can Copy

For information on the types of documents you can copy, their requirements, and details on loading documents, see Chapter 4.

Making Copies

Follow this procedure to make copies:

- 1 Adjust the paper delivery selector if necessary (→ p. 5-7).
- 2 Load the document, face down in the ADF (→ p. 4-3).
 - To adjust the contrast, see p. 7-3.

MEMORY USED 0%
(Currently used memory)

DOCUMENT READY
(Standby to scan)

- 3 Press **Start/Copy**.
- 4 Press **Image Quality** repeatedly until the resolution setting you want is displayed.
 - You can select from the following:
 - TEXT
Suitable for most text documents.
 - PHOTO
Suitable for documents that contain photographs.

COPY 100% 01

PHOTO

- 5 To make a reduced copy of your document, use ▼ or ▲ to select the reduction percentage you want.
 - You can select from the following:
 - 70%
 - 80%
 - 90%
 - 100%

COPY 80% 01

- 6** If you want to make multiple copies, use the numeric buttons to enter the number of copies.

COPY 80% 05

- You can make up to 99 copies.



Note

The machine copies at 400 × 300 dpi for single copies, and at 200 × 300 dpi for multiple copies. For best quality output, make one copy at a time.

- 7** Press **Start/Copy** to begin copying.

- To cancel copying, press **Stop/Reset**. You may then need to open the operation panel to remove the document from the ADF (→ p. 13-2).

COPYING



Note

You will be unable to make multiple copies if MEMORY FULL appears in the LCD. Print, send, or delete any documents you no longer need to be stored in the machine's memory (→ p. 9-4), then start again. Also, if you are copying multiple pages with many graphics, separate the pages into smaller stacks or make the desired number of copies one at a time as needed.

Chapter 11

Reports and Lists

This chapter describes the different reports and lists you can print from your machine. You will find samples of some of these reports and instructions for printing.

Summary of Reports and Lists	11-2
ACTIVITY REPORT	11-3
TX (Transmission) REPORT	11-4
MULTI TX/RX (Transaction) REPORT	11-5
RX (Reception) REPORT	11-5

Summary of Reports and Lists

The table below shows the lists and reports that can be printed from your machine. Refer to the pages indicated for more details.

Report or List	Description	Details
USER'S DATA LIST	Lists the current settings of your machine and the registered sender information.	p. 14-2
ACTIVITY REPORT	Shows recent facsimile transactions performed by your machine. You can enable or disable automatic printing of this report after every 20 transactions. You can also manually set the machine to print it.	p. 11-3 p. 14-5
TX (Transmission) REPORT	Prints after transmission of a document. You can enable or disable this feature, or set the machine to print a report only when an error occurs. You can also set the machine to print the first page of the document under the report to remind you of the contents of the document.	p. 11-4 p. 14-5
RX (Reception) REPORT	Prints after reception of a document. You can enable or disable this feature, or set the machine to print a report only when an error occurs.	p. 11-5 p. 14-5
MULTI TX/RX (Transaction) REPORT	Prints after sending the same document to several fax numbers, or after polling multiple fax numbers in one operation.	p. 11-5
DOC. MEMORY LIST	Lists the documents currently stored in the machine's memory.	p. 9-4
MEMORY CLEAR REPORT	Prints automatically when power is restored to the machine after a power failure. Lists the documents deleted from memory.	p. 13-21
1-TOUCH SPD DIAL LIST 1 1-TOUCH SPD DIAL LIST 2	Lists the numbers and names registered under one-touch speed dialing buttons.	p. 6-20
CODED SPEED DIAL LIST 1 CODED SPEED DIAL LIST 2	Lists the numbers and names registered under coded speed dialing codes.	p. 6-21
GROUP DIAL LIST	Lists groups registered under one-touch speed dialing buttons and coded speed dialing codes.	p. 6-22

ACTIVITY REPORT

The machine is factory-set to automatically print an ACTIVITY REPORT after every 20 transactions. If you want to print an ACTIVITY REPORT before it is automatically printed, follow this procedure:

1 Press Function.

2 Press Report.

ACTIVITY REPORT

3 Press Set.

- The machine prints an ACTIVITY REPORT.

PRINTING REPORT

Transactions in an ACTIVITY REPORT are listed chronologically. Sending transactions are numbered between 0001 and 4999, and receiving transactions are numbered between 5001 and 9999. When 4999 and 9999 are reached respectively, numbering reverts to 0001 and 5001 respectively.

12/26/2003 15:00 FAX 123 4567		CANON		001		
***** *** ACTIVITY REPORT *** *****						
ST. TIME	CONNECTION TEL	CONNECTION ID	NO.	MODE	PGS.	RESULT
* 12/26 13:43	905 795 1111	Canon CANADA	5001	AUTO RX	ECM	1 OK 00'33
* 12/26 13:45	905 795 1111	Canon CANADA	0001	POLLING RX	G3	0 NG 00'00 0 STOP
* 12/26 13:51	03 3758 2111	Canon TOKYO	0002	B'CAST	ECM	3 OK 01'18
* 12/26 13:53	2 887 0166	Canon AUSTRALIA	0002	B'CAST	ECM	3 OK 01'18
* 12/26 14:10	905 795 1111	Canon CANADA	5002	AUTO RX	ECM	1 OK 00'18
* 12/26 14:16	2 887 0166	Canon AUSTRALIA	5003	AUTO RX	ECM	4 OK 03'59
* 12/26 14:27	20 545 8545	Canon EUROPA	0003	DELAYED TX	ECM	1 OK 01'20
12/26 14:30	20 545 8545	Canon EUROPA	0004	DEL SQ BDCST	ECM	1 OK 00'36
12/26 14:31	03 3758 2111	Canon TOKYO	0004	DEL SQ BDCST	ECM	1 OK 00'36
12/26 14:57	2 887 0166	Canon AUSTRALIA	0005	TRANSMIT	ECM	3 NG 01'25
12/26 14:59	1 432 2060	CANON OPTICS	0006	TRANSMIT		3 STOP 0 00'01 0 #018

INDICATES AN ENTRY THAT HAS APPEARED ON A PREVIOUS REPORT.

TRANSACTION (TX/RX) NUMBER

TRANSACTION MODE

ERROR CORRECTION MODE TRANSACTION

ERROR PAGE

ERROR CODE (→ p. 13-8)

Stop/Reset PRESSED DURING TRANSACTION

TRANSACTION DURATION



- If you prefer your machine not to print an ACTIVITY REPORT after every 20 transactions, disable the ACTIVITY REPORT setting (→ p. 14-5).
- Please note that only one transaction number (TX/RX NO.) is assigned when you send a document to several fax numbers in one operation.

TX (Transmission) REPORT

The machine is factory-set to print a TX (transmission) REPORT only when an error occurs during sending. To change this setting, see TX REPORT, p. 14-5.

If you set your machine to print a report, a TX REPORT or an ERROR TX REPORT similar to the ones below, will be printed depending on the setting you select.

```

12/26/2003 14:52 FAX 123 4567          CANON          001
*****
*** TX REPORT ***
*****

TRANSMISSION OK

TX/RX NO          0003
CONNECTION TEL    1 432 2060
SUBADDRESS
    
```

```

12/26/2003 14:59 FAX 123 4567          CANON          001
*****
*** ERROR TX REPORT ***
*****

TX FUNCTION WAS NOT COMPLETED

TX/RX NO          0004
CONNECTION TEL    20 545 8545
SUBADDRESS
CONNECTION ID    Canon EUROPA
ST. TIME         12/26 14:59
USAGE T          00'18
PGS. SENT        1
RESULT           NG
    
```

THE SLEREXE COMPANY LIMITED

SAPORS LANE•BOOLE•DORSET•BH25 8ER
TELEPHONE BOOLE (945 13) 51617 – FAX 123456

Our Ref. 350/PJC/EAC 26 December, 2003

Dr. P. N. Cundall,
Mining Surveys Ltd.,
Holroyd Road,
Reading,
Berks.

OK: TRANSMISSION SUCCESSFUL
NG: SOME OR NO PAGES SENT

NUMBER OF PAGES SENT
TRANSMISSION DURATION
TRANSMISSION TIME

IF YOU ENABLE THE PRINT WITH IMAGE SETTING (→ p. 14-5), THE FIRST PAGE OF THE FAX WILL PRINT ON THE REPORT TO REMIND YOU OF THE CONTENTS OF THE FAX.

MULTI TX/RX (Transaction) REPORT

A MULTI TX/RX (transaction) REPORT similar to the one below, is printed when you send the same document to several fax numbers, or when you poll multiple fax numbers in one operation.

12/26/2003 17:23 FAX 123 4567		CANON		001
***** *** MULTI TX/RX REPORT *** *****				
TX/RX NO	0054			
PGS.	1			
TX/RX INCOMPLETE				
TRANSACTION OK	[01]905 795 1111	Canon CANADA		
	[*01]03 3758 2111	Canon TOKYO		
	[*02]1 49 39 25 25	Canon FRANCE		
ERROR INFORMATION	-----			

RX (Reception) REPORT

The machine is factory-set not to print an RX (reception) REPORT even if an error occurs during reception. To change this setting, see RX REPORT, p. 14-5.

If you set your machine to print a report, an RX REPORT similar to the one below, will be printed.

12/26/2003 15:02 FAX 123 4567		CANON		001
***** *** RX REPORT *** *****				
RECEPTION OK				
TX/RX NO	5004	905 795 1111		
CONNECTION TEL				
SUBADDRESS				
CONNECTION ID	Canon CANADA			
ST. TIME	12/26 14:59			
USAGE T	01'59			
PGS.	4			
RESULT	OK			

OK: RECEPTION SUCCESSFUL
NG: SOME OR NO PAGES RECEIVED
NUMBER OF PAGES RECEIVED
RECEPTION DURATION
RECEPTION TIME

Chapter 12

Maintenance

This chapter describes the steps you need to follow to keep your machine clean. You will also find instructions for replacing the cartridge.

Periodic Cleaning	12-2
Cleaning the Machine's Exterior.....	12-2
Cleaning the Machine's Interior.....	12-2
Cleaning the Scanner Components	12-5
Replacing the FX-3 Cartridge	12-7

Periodic Cleaning

This section describes the necessary cleaning procedures for your machine. Please note the following before cleaning your machine:

- Be sure to disconnect the power cord before cleaning the machine. Since documents in memory are erased when the power is disconnected, print or send any documents stored in memory before disconnecting the power cord (→ p. 9-4).
- Do not use tissue paper, paper towels, or similar materials for cleaning; they can stick to the components or generate static charges.



Never use volatile liquids such as thinners, benzene, acetone, or any other chemical cleaner to clean the interior of the machine; these can damage the machine's components.

Cleaning the Machine's Exterior

Follow this procedure to clean the machine's outer casing:

- 1** Disconnect the power cord from the machine.
- 2** Wipe the machine's exterior with a clean, soft, lint-free cloth moistened with water or diluted dishwashing detergent solution.
- 3** When you are finished, reconnect the power cord.

Cleaning the Machine's Interior

To prevent toner powder and paper dust from accumulating inside the machine and affecting print quality, clean the machine's print area periodically.

Follow this procedure to clean inside the machine:

- 1** Disconnect the power cord from the machine.
- 2** Lift the latch and open the front cover.



Do not try to open the front cover without lifting the latch since this may damage your machine.

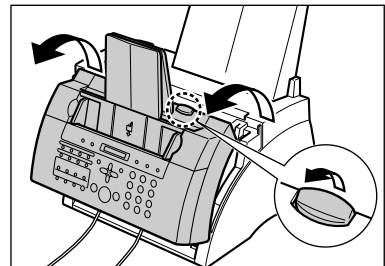

- 3** Hold the cartridge by its handle and remove it from the machine.
- To avoid exposing the cartridge to light, place it in its protective bag or wrap it in a thick cloth.

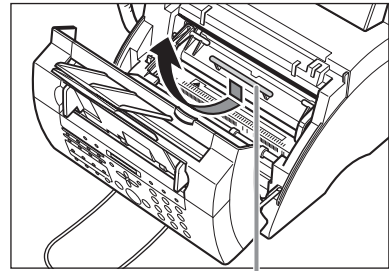

HANDLE

- 4** Use a clean, soft, dry, lint-free cloth to remove any toner or paper debris from the machine's interior (shaded area in the illustration).



- **The fixing assembly becomes extremely hot when the machine is in use. Be very careful not to touch it so as to avoid injury.**
- **Be careful not to touch the black transfer charging roller since this adversely affects print quality.**

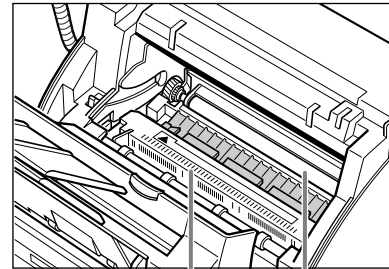

DO NOT TOUCH THE
FIXING ASSEMBLY

DO NOT TOUCH THE BLACK
TRANSFER CHARGING ROLLER

- 5** When you are finished, reinsert the cartridge. Hold the cartridge by its handle and insert it into the machine as far as it will go, making sure that its tabs are aligned with the rails inside the machine.
- Always hold the cartridge by its handle.

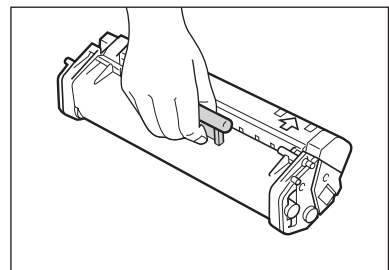
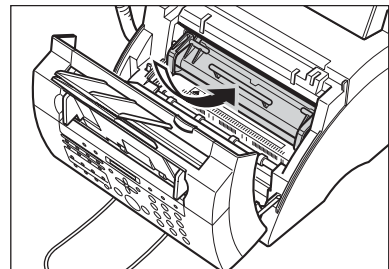

- 6** Use both hands to close the front cover.

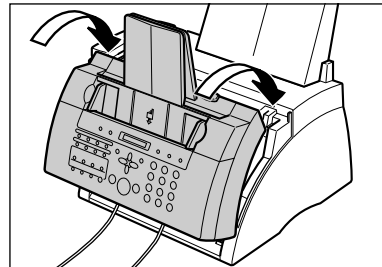

- 7** Reconnect the power cord.

Cleaning the Scanner Components

Follow this procedure to periodically check and clean the scanner components:

- 1 Disconnect the power cord from the machine.
- 2 Use both hands to gently open the operation panel.
 - It only opens partially.

- 3 While holding the operation panel open, clean these components:

■ **Separation guide and separation roller:**

Wipe with a clean, soft, dry, lint-free cloth.

■ **White sheet and scanning glass:**

Wipe with a clean, soft, lint-free cloth moistened with water, then wipe with a clean, soft, dry, lint-free cloth.



Note

- If the scanner components are dirty, the documents you send or copy will also be dirty.
- Be sure to use a soft cloth to avoid scratching the components.
- Do not use tissue paper, paper towels, or similar materials for cleaning; they can stick to the components or generate static charges.

- 4 Clean the underside of the operation panel (shaded area in the illustration).
 - Dirt and dust particles that collect on the underside of the operation panel affect the quality of the documents you copy or send.

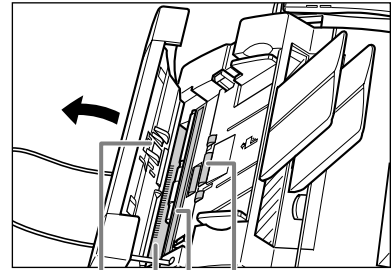

SEPARATION ROLLER
SCANNING GLASS
WHITE SHEET
SEPARATION GUIDE

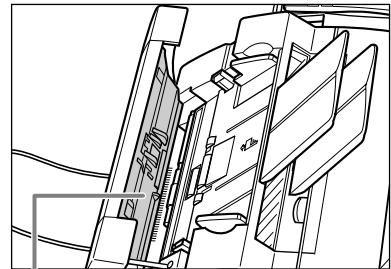

UNDERSIDE OF OPERATION PANEL

- 5** Use a clean, soft, dry, lint-free cloth to wipe any paper dust from the areas surrounding the separation roller (shaded area in the illustration).

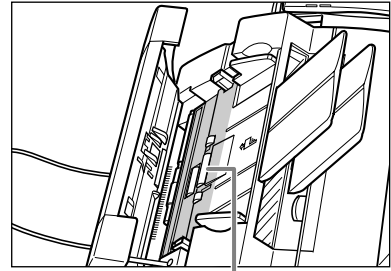

SEPARATION
ROLLER

- 6** When you are finished, close the operation panel by pressing it down from the center.
- Be sure to close the operation panel until it locks into place, or the machine will not function properly.
- 7** Reconnect the power cord.

Replacing the FX-3 Cartridge

The only component of your machine you will need to replace is the FX-3 cartridge. The FX-3 S Cartridge is a starter cartridge that comes with your machine, and yields approximately 1,500 pages based on 5% coverage of an A4 size page. The replacement FX-3 cartridge yields approximately 2,700 pages based on 5% coverage of an A4 size page. To purchase this cartridge, contact the Canon Customer Care Center, or your business machine retailer/dealer.

When CHANGE CARTRIDGE appears in the LCD, you may need to replace the cartridge. However, it may also indicate that the toner inside the cartridge is simply unevenly distributed. Before replacing the cartridge, follow this procedure to distribute the toner evenly:

- 1** Remove the cartridge from the machine (→ steps 1 to 4, below).
- 2** Gently rock the cartridge from side to side a few times to distribute the toner evenly inside it.
 - Poor print quality may result if the toner is unequally distributed.

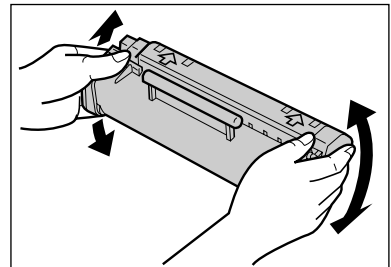

- 3** Reinsert the cartridge into the machine (→ steps 8 and 9, p. 12-9).

If after following the procedure above, CHANGE CARTRIDGE remains in the LCD or print quality does not improve, follow this procedure to replace the cartridge:

- 1** Remove any documents and printouts from the machine.
- 2** Make sure the machine is plugged in.
- 3** Lift the latch and open the front cover.



Do not try to open the front cover without lifting the latch since this may damage your machine.

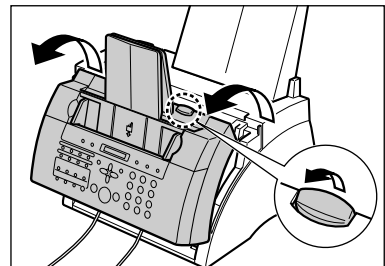

- 4** Hold the cartridge by its handle and remove it from the machine.
- Discard the old cartridge immediately according to the local laws and regulations for disposal of consumables. To recycle your used cartridge, simply follow the instructions included with your new FX-3 cartridge.

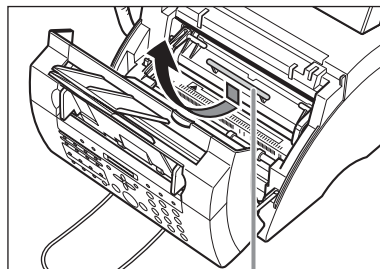

HANDLE

- 5** Remove the new FX-3 cartridge from its protective bag.
- Save the protective bag in case you need to repack the cartridge at a later date.

- 6** Gently rock the cartridge from side to side a few times to distribute the toner evenly inside it.
- Poor print quality may result if the toner is unequally distributed.

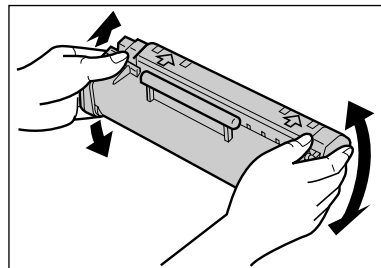

- 7** Place and support the cartridge on a flat, clean surface, then gently pull on the plastic tab to remove the plastic seal.
- Use a firm, even pull to avoid breaking the seal.

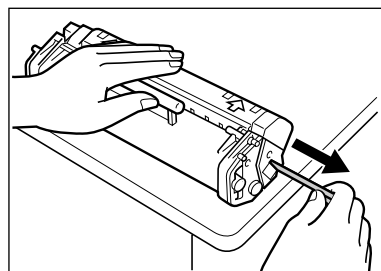

SIDE VIEW

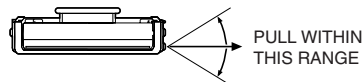

TOP VIEW

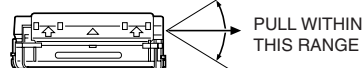

- 8** Hold the cartridge by its handle and insert it into the machine as far as it will go, making sure that its tabs are aligned with the rails inside the machine.
- Always hold the cartridge by its handle.

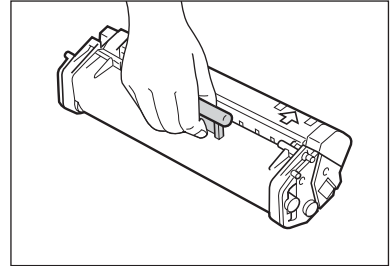
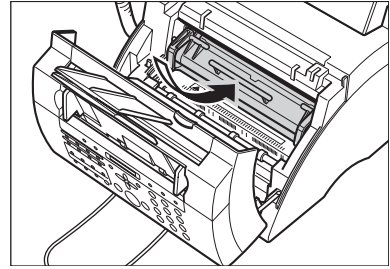

- 9** Use both hands to close the front cover.

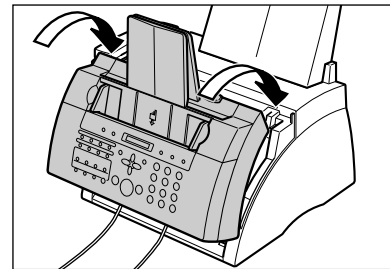

Chapter 13

Troubleshooting

If your machine is not operating properly, use the information and suggestions in this chapter to try to fix the problem.

Clearing Jams	13-2
Jams in the ADF	13-2
Paper Jams	13-3
Jams in the Paper Delivery Slots	13-3
Jams Inside the Machine	13-3
LCD Messages	13-8
Paper Feeding Problems	13-13
Printing Problems	13-14
Faxing Problems	13-15
Sending Problems	13-15
Receiving Problems	13-16
Copying Problems	13-18
Telephone Problems	13-19
General Problems	13-19
If You Cannot Solve a Problem	13-20
If a Power Failure Occurs	13-21

Clearing Jams

Jams in the ADF

When a document jams or misfeeds in the ADF, the LCD displays CHECK DOCUMENT.

Follow this procedure to clear the document jam:



You do not need to unplug your machine when clearing document jams.

1 Press **Stop/Reset**.

2 Use both hands to gently open the operation panel.

- It only opens partially.
- Do not try to pull the document out without opening the operation panel since you may tear or smudge the document.

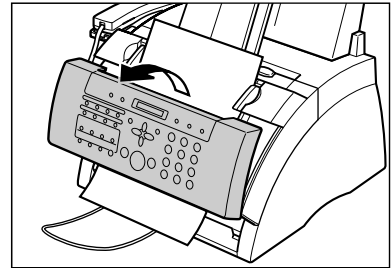

3 While holding the operation panel open, remove the document.

- Pull it gently in either direction.
- If a multipage document is loaded, remove the entire document from the ADF.



If the paper does not pull out easily, do not force it. Contact the Canon Customer Care Center.

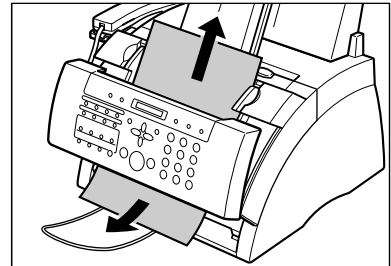

4 When you are finished, close the operation panel by pressing it down from the center.

- Be sure to close the operation panel until it locks into place, or the machine will not function properly.

Paper Jams

When paper jams in the machine, the LCD displays CLEAR PAPER JAM. Try clearing the jam by following the procedure in *Jams in the Paper Delivery Slots* below. If this does not clear the jam, follow the procedure in *Jams Inside the Machine*.

Jams in the Paper Delivery Slots

Follow this procedure to clear a paper jam in the paper delivery slots:



You do not need to unplug your machine when clearing paper jams.

- 1 Gently pull any jammed paper out of the machine as shown.

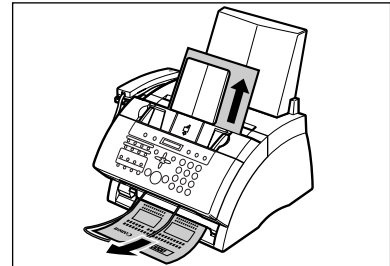

- 2 Remove the paper stack from the multi-purpose tray and reload it (→ p. 2-16).



If the paper jam occurred while a fax was being received into the machine's memory, that fax will print automatically when the jam is cleared.

Jams Inside the Machine

Follow this procedure to clear a paper jam inside the machine:



You do not need to unplug your machine when clearing paper jams.

- 1 Lift the latch and open the front cover.



Do not try to open the front cover without lifting the latch since this may damage your machine.

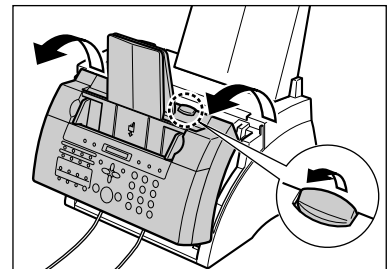

- 2** Hold the cartridge by its handle and remove it from the machine.
- To avoid exposing the cartridge to light, place it in its protective bag or wrap it in a thick cloth.

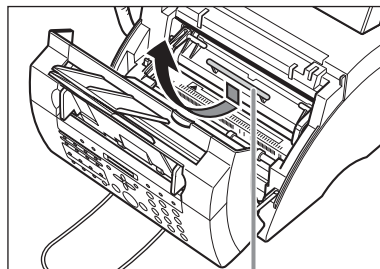

HANDLE

- 3** Move the paper release lever back.

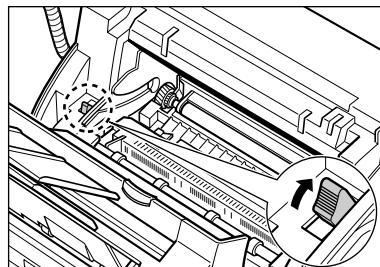

- The fixing assembly becomes extremely hot when the machine is in use. Be very careful not to touch it so as to avoid injury.
- Be careful not to touch the transfer charging roller since this adversely affects print quality.

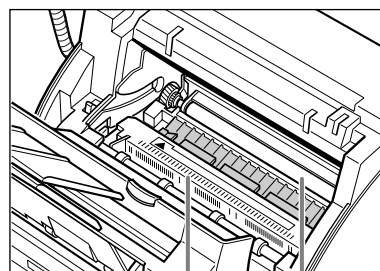

DO NOT TOUCH THE
FIXING ASSEMBLY

DO NOT TOUCH THE BLACK
TRANSFER CHARGING ROLLER

- 4** Locate the paper jam and clear it as explained on the following pages.

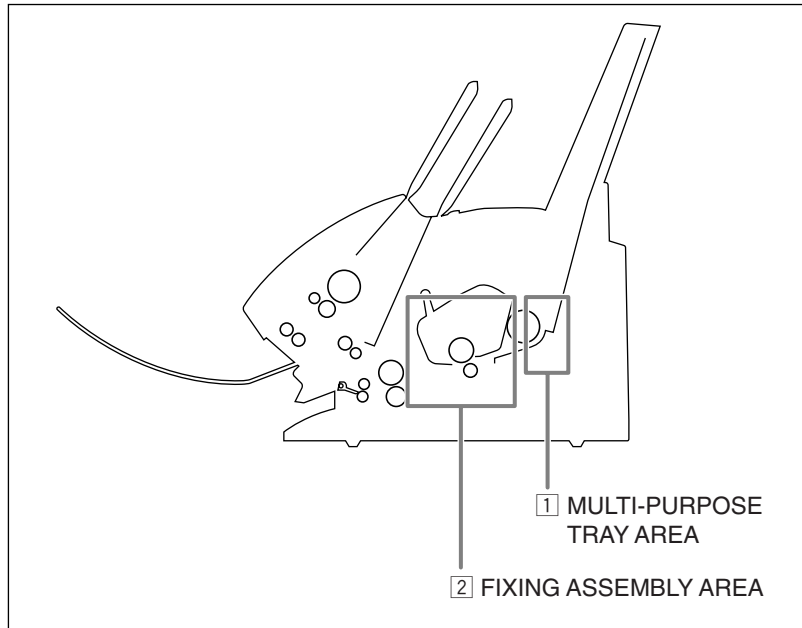

1 Multi-purpose tray area:

Hold the machine steady and carefully pull the jammed paper straight out from the machine.

- Do this carefully to prevent tearing the jammed paper. If you do tear it, be sure to remove any torn pieces from the machine since these will cause paper to jam again.
- The toner on the paper will not have been fixed to the paper yet, so remove the jammed paper carefully to avoid soiling the inside of the machine. Loose toner powder inside the machine may adversely affect print quality.
- Loose toner powder can soil any surface; protect yourself and your work area. Remove immediately any toner powder from yourself or your clothing with cold water.

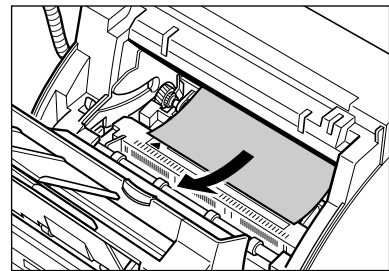

2 Fixing assembly area:

Top edge of the jammed paper in the fixing assembly:

Push the jammed paper back ①, then pull it carefully toward you to remove it ②.



The fixing assembly becomes extremely hot when the machine is in use. Be very careful not to touch it so as to avoid injury.

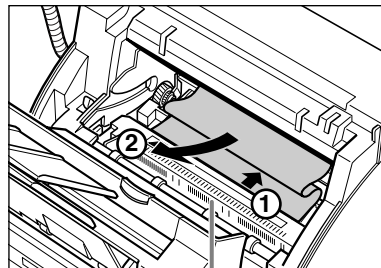

DO NOT TOUCH THE FIXING ASSEMBLY

Top edge of the jammed paper has passed through the fixing assembly:

Pass the jammed paper under the roller.

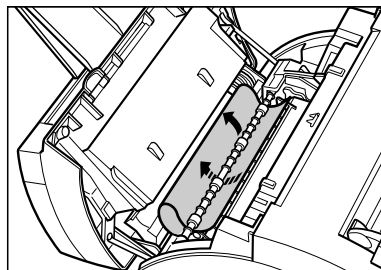

Use both hands to carefully pull out the jammed paper.

- Do this carefully to prevent tearing the jammed paper. If you do tear it, be sure to remove any torn pieces from the machine since these will cause paper to jam again.

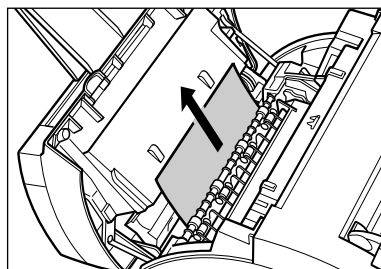

- 5** When you are finished, reinsert the cartridge. Hold the cartridge by its handle and insert it into the machine as far as it will go, making sure that its tabs are aligned with the rails inside the machine.

- Always hold the cartridge by its handle.

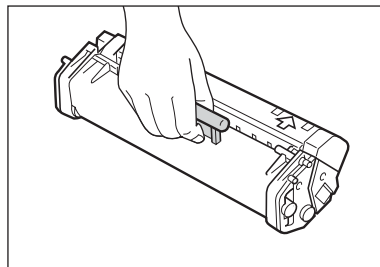
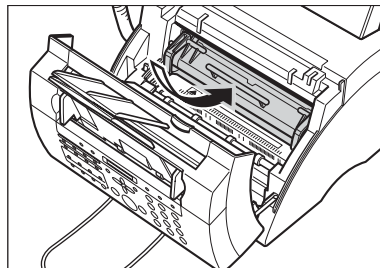

- 6** Move the paper release lever forward.
- 7** Use both hands to close the front cover.

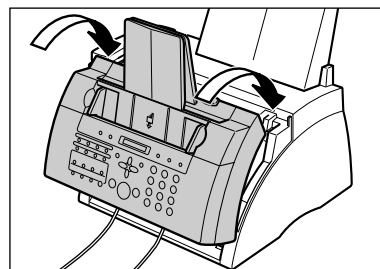

- 8** Reload paper in the multi-purpose tray (→ p. 2-16).



- If you are experiencing repeated paper jams, it may be due to the paper you are using:
- Tap the paper on a flat surface before stacking it in the multi-purpose tray.
 - Check that the paper you are using meets the requirements for your machine (→ p. 5-2).
 - Make sure you have completely removed any scraps of paper from inside the machine. Not doing so will cause paper to jam again.

LCD Messages

The following messages are displayed in the LCD when the machine is performing a task, or when it encounters an error. The error code appears in the ACTIVITY REPORT (→ p. 11-3).

Message	Error Code	Cause	Action
AUTO REDIAL	—	The machine is waiting to redial the other party's fax number because the line was busy or the other party did not answer when you tried to send the document.	Wait for the machine to automatically redial the fax number (→ p. 7-9).
BUSY/NO SIGNAL	#018	The fax/telephone number you dialed is busy.	Try sending the document at a later time.
		The fax number dialed was incorrect.	Check the fax number and dial again.
		The other party's fax machine is not working.	Contact the other party and have them check their fax machine.
		The other party is not using a G3 fax machine.	Contact the other party to check that they are using a G3 fax machine.
		The telephone line type setting on your machine is incorrect.	Set your machine for your telephone line type (→ p. 3-8).
		The receiving fax machine did not answer within 55 seconds (after all automatic redialing attempts).	Contact the other party and have them check their fax machine. You can try to send the document using manual sending via the handset (→ p. 7-6). For an overseas call, add pauses to the registered number (→ p. 9-2).
CHANGE CARTRIDGE	—	The toner inside the cartridge may be unevenly distributed.	Redistribute the inside the cartridge (→ p. 12-7). If the message remains, replace the cartridge (→ p. 12-7).

Message	Error Code	Cause	Action
CHANGE CARTRIDGE (Continued)		The cartridge is empty.	Replace the FX-3 cartridge (→ p. 12-7).
CHECK COVER	—	The front cover is open.	Close the front cover.
CHECK DOCUMENT	#001	A document is jammed in the ADF.	Clear the document jam (→ p. 13-2). Then start again.
CHECK PAPER SIZE	—	The size of the paper in the multi-purpose tray and that specified in the PAPER SIZE setting are different.	Load the correct paper size (→ p. 2-16) or change the PAPER SIZE setting (→ p. 5-9) to match the size of the paper loaded in the multi-purpose tray.
CHECK POLLING ID	#021	The subaddress and/or password do not match the settings on the other party's fax machine.	Make sure the subaddress and/or password match the settings on the other party's fax machine (→ p. 9-9).
	#008	No subaddress and/or password has been entered on the other party's machine, or the subaddress and/or password do not match the settings on your machine.	Contact the other party to enter the correct subaddress and/or password.
CHECK PRINTER	—	The cartridge may be defective.	Reinstall the cartridge (→ p. 2-13). If the message remains in the LCD, replace the cartridge (→ p. 12-7).
		The machine is connected to an uninterruptible power supply (UPS).	Make sure the machine is plugged into an AC outlet. In either case, if the error does not clear, try unplugging the machine. Wait five seconds, then plug it back in. If the message remains in the LCD, contact the Canon Customer Care Center.

Message	Error Code	Cause	Action
CHK SUBADDR/PSWD	#083/102	You attempted to send a document or poll another fax machine with the incorrect subaddress and/or password.	Contact the other party to check their settings. Change your settings if necessary (→ pp. 6-3, 6-8).
CLEAR PAPER JAM	—	There is a paper jam.	Clear the paper jam (→ p. 13-3), then reload paper in the multi-purpose tray (→ p. 2-16).
DOC. TOO LONG	#003	The document is longer than 39.4 inches (1 meter).	Use a copier to make a reduced copy of the document and then send the copy.
ECM RX	—	The machine is receiving a fax using Error Correction Mode (ECM).	Receiving with ECM may take longer than normal receptions. Turn off ECM if you need to receive quickly, or if you know your local lines are in good condition (→ ECM RX, p. 14-7).
ECM TX	—	The machine is sending a fax using Error Correction Mode (ECM).	Sending with ECM may take longer than normal transmissions. Turn off ECM if you need to transmit quickly, or if you know your local lines are in good condition (→ ECM TX, p. 14-6).
LOAD PAPER	—	The multi-purpose tray is empty.	Load paper in the multi-purpose tray (→ p. 2-16), then press Stop/Reset .

Message	Error Code	Cause	Action
MEMORY FULL	#037	<p>The machine's memory is full because it has received too many documents, or a very long or detailed document.</p> <p>The machine's memory is full because you tried to send too many pages at once, or a very long or detailed document.</p>	<p>Print any documents you no longer need to be stored in memory (→ p. 9-5). Then start again.</p> <p>Divide the document and send each part separately. To free up space in the machine's memory, print, send, or delete any documents you no longer need to be stored in memory (→ p. 9-4).</p>
MEMORY USED <i>nn</i> %	—	Shows the percentage of memory currently in use.	If you need more space, wait for the machine to send any faxes. Also, print, send, or delete any documents you no longer need to be stored in memory (→ p. 9-4).
NO RX PAPER	#012	The other party's fax machine is out of paper or its memory is full.	Contact the other party and have them load paper in their fax machine or free up space in their fax machine's memory.
NO TEL #	#022	The one-touch speed dialing button or coded speed dialing code you entered has not been registered.	Register the one-touch speed dialing button or coded speed dialing code (→ Chapter 6).
NOT AVAILABLE	—	You entered an invalid number.	Enter a valid number.
PSWD POLL REJECT	#084	You attempted to poll a fax machine with a password, but the other party has not set a password or their fax machine does not support polling with a password.	Contact the other party to check their settings. If their fax machine does not support polling with a password, delete the password you have registered (→ pp. 6-3, 6-8).

Message	Error Code	Cause	Action
PSWD TX REJECTED	#081	You attempted to send a document with a password, but the other party's fax machine does not support reception with a password.	Contact the other party to check their settings. If their fax machine does not support reception with a password, delete the password you have registered (→ pp. 6-3, 6-8).
REC'D IN MEMORY	—	The machine received the fax in memory because paper or toner ran out, or a paper jam occurred during reception. The loaded paper size may not match the size of the fax being received.	Load paper in the multi-purpose tray (→ p. 2-16), replace the cartridge (→ p. 12-7), or clear the paper jam (→ p. 13-3). Load the correct paper in the multi-purpose tray (→ p. 2-16).
SELECT POL REJECT	#082	You attempted to poll a fax machine with a subaddress, but the other party has not set a subaddress or their fax machine does not support polling with a subaddress.	Contact the other party to check their settings. If their fax machine does not support polling with a subaddress, delete the subaddress you have registered (→ pp. 6-3, 6-8).
SUBADD TX REJECT	#080	You attempted to send a document with a subaddress, but the other party's fax machine does not support reception with a subaddress.	Contact the other party to check their settings. If their fax machine does not support reception with a subaddress, delete the subaddress you have registered (→ pp. 6-3, 6-8).
TX/RX CANCELLED	—	You pressed Stop/Reset to cancel a transaction.	—
TX/RX NO. <i>nnnn</i>	—	The number shown (<i>nnnn</i>) is a unique identification number assigned to the document you are sending or receiving.	This number appears in reports so you can identify transactions. Write the number down if you will need it later.
TX/RX NO. <i>nnnn</i> SCANNING P. <i>nnn</i> MEMORY FULL (Three messages toggle.)	—	The machine is sending a document and its memory is full.	The machine continues to send the document as memory becomes available.

Paper Feeding Problems

■ Paper does not feed properly.

The multi-purpose tray may contain too many sheets.

- Make sure you load the correct quantity (→ p. 5-2).

The print media may not be loaded correctly.

- Make sure the print media is loaded correctly in the multi-purpose tray (→ p. 5-4).

■ Multiple sheets feed together into the machine.

The print media may not be loaded correctly.

- Make sure the print media is loaded correctly in the multi-purpose tray (→ p. 5-4).

The multi-purpose tray may contain too many sheets.

- Make sure you load the correct quantity (→ p. 5-2).

Different types of print media may be loaded in the multi-purpose tray.

- Load only one type of print media.
- Make sure you load print media that meets the requirements for the machine (→ p. 5-2).
- Let the print media run out before refilling the multi-purpose tray. Avoid mixing new stock with print media already loaded.

■ Repeated paper jams occur.

The print media you are using may be causing the jams.

- Make sure you load print media that meets the requirements for the machine (→ p. 5-2).

■ Envelopes do not load.

Envelopes may not be loaded correctly.

- Make sure the envelopes are loaded properly (→ p. 5-5). Do not load more than 7 envelopes in the multi-purpose tray.

The envelopes you are using may not meet the requirements for the machine.

- Make sure you load envelopes that meets the requirements for the machine (→ p. 5-2).

The envelopes may not be feeding properly.

- Make sure you are using face-up delivery (→ p. 5-7).

Printing Problems

■ The machine beeps while printing.

The machine may have a paper jam.

- Clear the paper jam (→ p. 13-3).

■ Nothing prints.

The power cord may not be plugged in securely.

- Check that the power cord is plugged securely into the machine and into the wall outlet (→ p. 2-9). If the machine is plugged into a power strip, make sure the power strip is plugged in and turned on.

You may not have removed the plastic seal from the cartridge.

- Make sure you install the cartridge properly (→ p. 2-13).

The cartridge may need to be replaced.

- Replace the cartridge (→ p. 12-7).

■ Printout does not match the print media size.

The print media may not be loaded correctly.

- Make sure the print media is loaded correctly in the multi-purpose tray (→ p. 5-4).

■ Printout is skewed.

The print media may not be loaded correctly.

- Make sure the print media is loaded correctly in the multi-purpose tray (→ p. 5-4).
- Make sure the paper delivery slots are clear.

■ Print media jams occur.

You may not be using the correct paper delivery slot.

- Select the correct paper delivery slot (→ p. 5-7).

■ Printout is not clear.

You may not be using the correct print media type.

- Make sure you load print media that meets the requirements for the machine (→ p. 5-2).

You may be printing on the wrong side of the paper.

- Some papers have a “right” side for printing. If the print quality is not as clear as you would like it to be, try turning the paper over and printing on the other side.

■ Printout has vertical white streaks.

Toner may be low or unevenly distributed.

- Redistribute the toner inside the cartridge (→ p. 12-7). If the problem persists, replace the cartridge (→ p. 12-7).

Faxing Problems

Sending Problems

■ Cannot send a fax.

The machine may not be set for the correct telephone line type.

- Make sure the machine is set for the correct telephone line type (→ p. 3-8).

The document may not be loaded correctly.

- Make sure the document is loaded correctly in the ADF (→ p. 4-3).
- Make sure the operation panel is closed.

The one-touch speed dialing button or coded speed dialing code you entered may not be registered correctly.

- Check that the speed dialing settings are registered correctly (→ Chapter 6).

You dialed or have been provided with an incorrect number.

- Dial the number again, or check that you have the correct number.

The other party's fax machine may be out of paper.

- Contact the other party and ask them to make sure paper is loaded in their fax machine.

There may be other documents being sent from memory.

- Allow time for those documents to finish sending.

An error may have occurred during sending.

- Print an ACTIVITY REPORT (→ p. 11-3) and check for an error code (→ p. 13-8).

The telephone line may not be working properly.

- Make sure there is a dial tone when you press **Hook** or when you lift the handset of any external device connected to the machine. If there is no dial tone, contact your local telephone company.

The receiving fax machine may not be a G3 fax machine.

- Make sure the receiving fax machine is compatible with your machine (which is a G3 fax machine).

The subaddress and/or password are incorrect.

- If you registered a subaddress/password under a speed dialing button or code, make sure they match the other party's settings.

■ Faxes sent from the machine are spotted or dirty.

The receiving fax machine may not be working properly.

- Check the machine by making a copy (→ p. 10-2). If the copy is clear, the problem may be in the receiving fax machine. If the copy is spotted or dirty, clean the scanner components (→ p. 12-5).

The document may not be loaded correctly.

- Make sure the document is loaded correctly in the ADF (→ p. 4-3).

■ **Cannot send using Error Correction Mode (ECM).**

The other party's fax machine may not support ECM.

- If this is the case, the document is sent without ECM.

ECM may be disabled.

- Make sure ECM on your machine is enabled (→ ECM TX, p. 14-6).
- Contact the other party to check if ECM on their fax machine is enabled.

■ **Errors occur frequently while sending.**

The telephone lines may be in poor condition, or you may have a bad connection.

- Lower the transmission speed (→ TX START SPEED, p. 14-10).



If none of these solutions solve the problem, unplug the machine and wait for at least five seconds. Then plug it back in and try sending again. If you still cannot send, contact the Canon Customer Care Center.

Receiving Problems

■ **Cannot receive a fax automatically.**

The machine may not be set to receive automatically.

- For the machine to receive faxes automatically, the receive mode must be set to FAX ONLY MODE, Fax/Tel Mode, ANS.MACHINE MODE, or DRPD (→ Chapter 8). If you have set ANS.MACHINE MODE, confirm that an answering machine is connected to the machine and that it is turned on with an outgoing message properly recorded (→ p. 8-9).

The machine may have a document stored in memory, leaving little or no memory available.

- Print, send, or delete any documents you no longer need to be stored in memory (→ p. 9-4).

An error may have occurred during reception.

- Check the LCD for an error message (→ p. 13-8).
- Print an ACTIVITY REPORT (→ p. 11-3) and check for an error code (→ p. 13-8).

The multi-purpose tray may be empty.

- Make sure paper is loaded in the multi-purpose tray (→ p. 2-16).

The telephone line cord may not be connected properly.

- Make sure it is connected properly (→ p. 2-8).

■ No automatic switching between telephone and fax calls.

The machine may not be set to switch automatically between telephone and fax calls.

- For the machine to switch automatically, the receive mode must be set to Fax/Tel Mode, ANS.MACHINE MODE, or DRPD (→ Chapter 8). If you have set ANS.MACHINE MODE, confirm that an answering machine is connected to the machine and that it is turned on with an outgoing message properly recorded (→ p. 8-9).

The machine may have a document stored in memory, leaving little or no memory available.

- Print, send, or delete any documents you no longer need to be stored in memory (→ p. 9-4).

An error may have occurred during reception.

- Check the LCD for an error message (→ p. 13-8).
- Print an ACTIVITY REPORT (→ p. 11-3) and check for an error code (→ p. 13-8).

The multi-purpose tray may be empty.

- Make sure paper is loaded in the multi-purpose tray (→ p. 2-16).

The other party's fax machine may not send the CNG signal that tells your machine that the incoming call is a fax call.

- Some fax machines cannot send this signal. In such cases, you will have to receive the fax manually (→ p. 8-6).

■ Cannot receive a document manually.

You may have disconnected the call by pressing Start/Copy or dialing the remote receiving ID after hanging up.

- Always press **Start/Copy** or dial the remote receiving ID *before* hanging up. Otherwise you will disconnect the call (→ p. 8-6).

■ Print quality is poor.

You may not be using the correct paper type.

- Make sure you load paper that meets the requirements for the machine (→ p. 5-2).

The other party's fax machine may not be functioning properly.

- The sending fax machine usually determines the machine's quality. Contact the other party and have them check that the scanning components of their fax machine are clean.

Error Correction Mode (ECM) may be disabled.

- Make sure ECM is on (→ ECM RX, p. 14-7).

■ Faxes do not print.

The cartridge may not be installed properly.

- Make sure the cartridge is installed properly (→ p. 2-13).

The cartridge may need to be replaced.

- Replace the cartridge (→ p. 12-7).

■ Received faxes print blotched or unevenly.

The telephone lines may be in poor condition, or you may have a bad connection.

- Error Correction Mode (ECM) sending/receiving should eliminate such problems. However, if the telephone lines are in poor condition, you may have to try again.

The other party's fax machine may not be functioning properly.

- The sending fax machine usually determines the fax's quality. Contact the other party and have them check that the scanning components of their fax machine are clean.

Toner may be low or unevenly distributed.

- Redistribute the toner inside the cartridge (→ p. 12-7). If the problem persists, replace the cartridge (→ p. 12-7).

■ Cannot receive using Error Correction Mode (ECM).

The other party's fax machine may not support ECM.

- If this is the case, the document is received without ECM.

ECM may be disabled.

- Make sure ECM on your machine is enabled (→ ECM RX, p. 14-7).
- Contact the other party to check if ECM on their fax machine is enabled.

■ Errors occur frequently while receiving.

The telephone lines may be in poor condition, or you may have a bad connection.

- Lower the reception speed (→ RX START SPEED, p. 14-10).

The other party's fax machine may not be functioning properly.

- Contact the other party and have them check that their fax machine is functioning properly.

Copying Problems

■ Cannot make copies.

The document may not be loaded correctly.

- Make sure the document is loaded correctly in the ADF (→ p. 4-3).
- Make sure the operation panel is closed.

The document may not meet the requirements for the machine.

- Make sure you load documents that meet the requirements for the machine (→ p. 4-2).



For additional troubleshooting, see *Printing Problems*, p. 13-14.

Telephone Problems

■ Cannot dial.

The telephone line cord may not be connected properly.

- Make sure it is connected properly (→ p. 2-8).

The power cord may not be plugged in securely.

- Check that the power cord is plugged securely into the machine and into the wall outlet (→ p. 2-9). If the machine is plugged into a power strip, make sure the power strip is plugged in and turned on.

The machine may not be set for the correct telephone line type.

- Make sure the machine is set for the correct telephone line type (→ p. 3-8).

■ Handset or extension telephone disconnects while you are talking.

The power cord may not be plugged in securely.

- Check that the power cord is plugged securely into the machine and into the wall outlet (→ p. 2-9). If the machine is plugged into a power strip, make sure the power strip is plugged in and turned on.

The handset or extension telephone cord may be defective.

- Check the cord by substituting with another cord.

General Problems

■ Machine has no power.

The power cord may not be plugged in securely.

- Check that the power cord is plugged securely into the machine and into the wall outlet (→ p. 2-9). If the machine is plugged into a power strip, make sure the power strip is plugged in and turned on.

The power cord may not be supplying power.

- Check the power cord by substituting with another, or by using a voltmeter to test it for continuity.

■ Nothing appears in the LCD.

The power cord may not be plugged in securely.

- Check that the power cord is plugged securely into the machine and into the wall outlet (→ p. 2-9). If the machine is plugged into a power strip, make sure the power strip is plugged in and turned on. If the LCD remains blank, unplug the machine and wait five seconds, then plug it back in. If the LCD still remains blank, contact the Canon Customer Care Center.

If You Cannot Solve a Problem

If you have a problem with your machine that you cannot solve with the information provided in this chapter, contact the Canon Customer Care Center.



Attempting to repair the machine yourself may void the limited warranty.



If the machine makes strange noises, emits smoke or strange smells, unplug it immediately and contact the Canon Customer Care Center. Do not attempt to disassemble or repair the machine yourself.

If you contact the Canon Customer Care Center, make sure you have the following information ready:

- **Product name: FAXPHONE L80**
- **Serial number (on the label located at the back of the machine)**
- **Details of the problem**
- **Steps taken to try to resolve the problem and the results**

If a Power Failure Occurs

If power is suddenly lost due to a power failure or accidental unplugging, a built-in battery retains the machine's settings. However, any documents stored in memory will be lost.

During a power failure, functions are limited as follows:

- You cannot make telephone calls using the handset. Also, depending on your telephone, you may not be able to make calls using the extension telephone connected to your machine.
- You cannot send, receive, or copy documents.
- You can receive telephone calls through the handset. Also, depending on your telephone, you may be able to receive calls through the extension telephone connected to your machine.

When power is restored, your machine automatically prints a MEMORY CLEAR REPORT that lists the documents that were deleted from memory as a result of the power failure.

12/26/2003 16:48 FAX 123 4567		CANON		001	
***** *** MEMORY CLEAR REPORT *** *****					
MEMORY FILES DELETED					
TX/RX NO	MODE	CONNECTION TEL/ID	PGS.	SET TIME	ST. TIME
0046	TRANSMIT	[* 01] Canon TOKYO	3	12/26 16:03	
0047	B'CAST	[01] Canon CANADA	1	12/26 16:08	
		[* 02] Canon FRANCE			
0048	DEL SQ BDCST	[03] Canon ITALIA	1	12/26 16:15	20:00
		[04] Canon U.S.A.			20:00
0049	DELAYED TX	[08] Canon OPTICS	2	12/26 16:36	22:00



If the cartridge is empty or there is no paper in the multi-purpose tray when power is restored, the LCD displays CHANGE CARTRIDGE or LOAD PAPER. In these cases, the MEMORY CLEAR REPORT will not be printed even after the cartridge is replaced or paper is loaded.

Chapter 14

Summary of Settings

This chapter summarizes the settings of your machine and explains how to access them.

Understanding the Menu System	14-2
Printing a List to Check the Current Settings	14-2
Accessing the Menus	14-3
USER SETTINGS Menu	14-4
REPORT SETTINGS Menu	14-5
TX (Transmission) SETTINGS Menu	14-6
RX (Reception) SETTINGS Menu	14-7
PRINTER SETTINGS Menu	14-8
POLLING BOX Menu	14-9
SYSTEM SETTINGS Menu	14-10

Understanding the Menu System

The machine menu system allows you to customize the way your machine operates. It consists of seven menus, each containing settings that control different functions of your machine.

Before adjusting any settings, you may want to print the USER'S DATA LIST to check the current settings (→ below).

Printing a List to Check the Current Settings

You can print the USER'S DATA LIST to check the current settings of your machine as well as the registered sender information (→ p. 3-5).

Follow this procedure to print the USER'S DATA LIST:

1 Press **Function**.

2 Press **Report**.

ACTIVITY REPORT

3 Use ▼ or ▲ to select **USER DATA LIST**.

USER DATA LIST

4 Press **Set**.

- The machine prints the USER'S DATA LIST.

PRINTING REPORT

The sender information is shown at the beginning of the list. The current settings of the machine are listed after this.

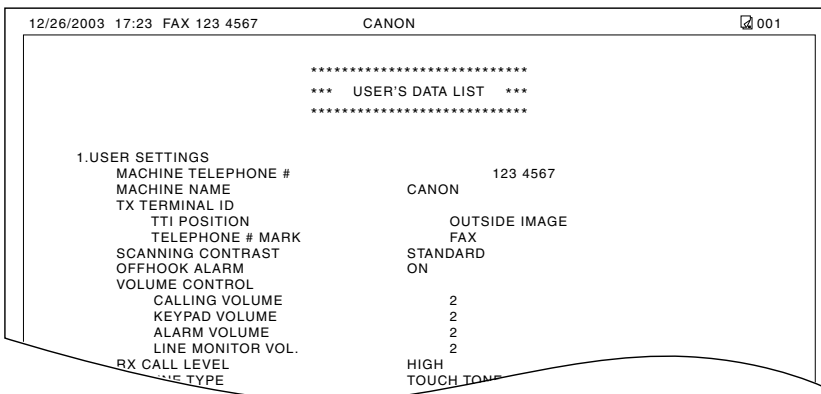

Accessing the Menus

Follow this procedure to access the different menus:

1 Press **Function**.

2 Press **Data Registration**.

DATA REGISTRATION

3 Press **Set**.

USER SETTINGS

4 Use ▼ or ▲ to select the menu you want.

- You can select from the following:
 - USER SETTINGS (→ p. 14-4)
 - REPORT SETTINGS (→ p. 14-5)
 - TX SETTINGS (→ p. 14-6)
 - RX SETTINGS (→ p. 14-7)
 - PRINTER SETTINGS (→ p. 14-8)
 - POLLING BOX (→ p. 14-9)
 - SYSTEM SETTINGS (→ p. 14-10)

5 Press **Set** to access the settings under the menu you selected.

ECM RX

6 Refer to the appropriate table (→ following pages) and use these guidelines to select and register settings:

- Use ▼ or ▲ to scroll through the settings.
- To register a setting or access sub-settings, press **Set**.
- To return to a previous level, press **Function** then **Data Registration**.
 - For your settings to be registered, be sure to press **Set** after making a selection or entering information.
 - If at any stage you wish to return to standby mode, press **Stop/Reset**.
 - If you pause for more than 60 seconds while accessing a menu, the machine will automatically return to standby mode.

7 When you are finished, press **Stop/Reset** to return to standby mode.

12/26

FaxTel

USER SETTINGS Menu

For details on accessing the settings below, see p. 14-3.

Default settings are shown in **bold** type.

Setting	Description	Sub-Settings
DATE & TIME	Sets the current date and time (→ p. 3-6).	–
UNIT TELEPHONE #	Enters the fax/telephone number you want to appear at the top of each fax page you send (→ p. 3-6).	–
UNIT NAME	Enters the name or company name you want to appear at the top of each fax page you send (→ p. 3-6).	–
TX TERMINAL ID	Sets the options for the sender information.	–
TTI POSITION	Selects whether the sender information is positioned inside or outside the image area (→ p. 3-5).	OUTSIDE IMAGE INSIDE IMAGE
TELEPHONE # MARK	Selects the prefix for the machine number (→ p. 3-5).	FAX TEL
SCAN CONTRAST	Selects the scanning contrast (→ p. 7-3).	STANDARD DARKER LIGHTER
OFFHOOK ALARM	Enables/disables the off hook alarm that alerts you that the handset is not seated properly in its cradle.	ON OFF
VOLUME CONTROL	Sets the volume of the machine sounds.	–
CALLING VOLUME	Selects the ring volume when the machine detects a voice call.	1/ 2 /3
KEYPAD VOLUME	Selects the keypad touch beep volume.	0 (off)/1/ 2 /3
ALARM VOLUME	Selects the error alarm volume.	0 (off)/1/ 2 /3
LINE MONITOR VOL	Selects the line monitor volume (sound during dialing).	0 (off)/1/ 2 /3
RX CALL LEVEL	Selects the ring type for incoming calls.	HIGH STANDARD
TEL LINE TYPE	Selects the telephone line type setting for your machine (→ p. 3-8).	TOUCH TONE ROTARY PULSE

REPORT SETTINGS Menu

For details on accessing the settings below, see p. 14-3.

Default settings are shown in **bold** type.

Setting	Description	Sub-Settings
TX REPORT	Enables/disables automatic printing of a TX (transmission) REPORT (→ p. 11-4). PRINT ERROR ONLY: Prints a report only when a transmission error occurs. OUTPUT YES: Prints a report every time you send a document. OUTPUT NO: No report is printed.	PRINT ERROR ONLY OUTPUT YES OUTPUT NO
PRINT WITH IMAGE	If you select PRINT ERROR ONLY or OUTPUT YES above, this setting enables/disables printing of the first page of the fax under the report.	ON OFF
RX REPORT	Enables/disables automatic printing of an RX (reception) REPORT (→ p. 11-5). OUTPUT NO: No report is printed. PRINT ERROR ONLY: Prints a report only when a reception error occurs. OUTPUT YES: Prints a report every time you receive a document.	OUTPUT NO PRINT ERROR ONLY OUTPUT YES
ACTIVITY REPORT	Enables/disables automatic printing of an ACTIVITY REPORT after every 20 transactions (→ p. 11-3).	AUTO PRINT ON AUTO PRINT OFF

TX (Transmission) SETTINGS Menu

For details on accessing the settings below, see p. 14-3.

Default settings are shown in **bold** type.

Setting	Description	Sub-Settings
ECM TX	Enables/disables Error Correction Mode (ECM) during transmission.	ON OFF
MID PAUSE SET	Selects the length of a pause entered within a fax/telephone number with the Pause button.	2 SEC (1 to 15)
AUTO REDIAL	Enables/disables automatic redialing if the other party's line is busy on the first attempt (→ p. 7-9).	ON OFF
REDIAL TIMES	Selects the number of redial attempts.	2 TIMES (1 to 10)
REDIAL INTERVAL	Selects the time interval between redial attempts.	2 MIN. (2 to 99)
TIME OUT	Enables/disables automatic scanning of documents after the fax number is entered. ON: Scanning begins automatically five seconds after entering the fax number (10 seconds if sending to multiple fax numbers). OFF: Scanning does not start automatically. (You need to press Start/Copy to begin scanning.)	ON OFF

RX (Reception) SETTINGS Menu

For details on accessing the settings below, see p. 14-3.

Default settings are shown in **bold** type.

Setting	Description	Sub-Settings
ECM RX	Enables/disables Error Correction Mode (ECM) during reception.	ON OFF
RX MODE	Selects the receive mode (→ Chapter 8). If you select FAX/TEL AUTO SW or DRPD, you can select additional sub-settings (→ pp. 8-4, 8-10).	FAX/TEL AUTO SW FAX ONLY MODE DRPD
INCOMING RING	When the RX MODE setting is set to FAX ONLY MODE or FAX/TEL AUTO SW, this setting enables/disables ringing when the machine receives a call.*	OFF ON
RING COUNT	Selects the number of rings before the machine begins receiving.	2 TIMES (1 to 99)
MAN/AUTO SWITCH	When the receive mode is set to MANUAL MODE, this setting determines if the machine switches to fax receive mode after it rings for a specified time.	OFF ON
F/T RING TIME	If you select ON above, this setting selects the length of time the machine rings before switching to fax receive mode.	15 SEC (1 to 99)
REMOTE RX	Enables/disables remote receiving.	ON OFF
REMOTE RX ID	If you select ON above, this setting selects the remote receiving ID.	25 (00 to 99)
MEMORY RX	Enables/disables reception of a document in the machine's memory when a problem occurs.	ON OFF
RX PAGE FOOTER	Enables/disables printing of the reception date and time, transaction number (TX/RX NO.), and page number at the bottom of each received fax page.	OFF ON

* Even if you have set INCOMING RING to ON, ringing will only occur if you have connected the handset or an extension telephone to your machine.

PRINTER SETTINGS Menu

For details on accessing the settings below, see p. 14-3.

Default settings are shown in **bold** type.

Setting	Description	Sub-Settings
RX REDUCTION	Enables/disables reduction of faxes to fit on the paper loaded in the multi-purpose tray. If you select ON, you can select the direction of the reduction.	ON OFF VERTICAL ONLY HORIZ & VERTICAL
PAPER SIZE	Selects the size of the paper loaded in the multi-purpose tray (→ p. 5-9). If you select CUSTOM, you can select additional sub-settings (→ p. 5-9).	LTR LGL CUSTOM A4
ECONOMY PRT	Enables/disables economy printing (→ p. 5-11).	OFF ON
TONER SUPPLY LOW	Selects whether the machine continues printing when toner level is low (CHANGE CARTRIDGE displayed in the LCD). RX TO MEMORY: Stops printing and received faxes are stored in memory. KEEP PRINTING: Ignores the warning and keeps printing the entire document. This setting is convenient when you do not have a new FX-3 cartridge at hand. Note however, that when you select this setting, the machine will not receive the document in memory when the cartridge is completely empty. Once you install a new FX-3 cartridge, be sure to set RX TO MEMORY.	RX TO MEMORY KEEP PRINTING

POLLING BOX Menu

For details on accessing the settings below, see p. 14-3.

Default settings are shown in **bold** type.

Setting	Description	Sub-Settings
SETUP FILE	Sets up the polling box to hold a document to be polled (→ p. 9-12).	–
FILE NAME	Enters the name for the polling box.	–
PASSWORD	Enters a password to restrict access to the polling box settings.	0000 to 9999
TX PASSWORD	Enters an ITU-T-standard password.	–
ERASE AFTER TX	Selects whether the document is deleted from memory once it is polled, or continues to be stored in memory. ON: Document is deleted from memory after it is polled. OFF: Document remains in memory after it is polled.	ON OFF
CHANGE DATA	Changes the polling box settings (→ p. 9-15).	–
PASSWORD	Enters the password (if registered) to access the polling box settings.	–
DELETE FILE	Deletes the polling box settings (→ p. 9-15).	–
PASSWORD	Enters the password (if registered) to access the polling box settings.	–

SYSTEM SETTINGS Menu

For details on accessing the settings below, see p. 14-3.

Default settings are shown in **bold** type.

Setting	Description	Sub-Settings
RX RESTRICTION	Restricts reception of faxes to the numbers registered for speed dialing on your machine (→ p. 9-17). If you select ON, you can select additional sub-settings.	OFF ON
DATE SETUP	Selects the date format displayed in the LCD and printed on the faxes you send.	MM/DD/YYYY DD/MM YYYY YYYY MM/DD
DISPLAY LANGUAGE	Selects the language of the LCD messages, settings, and reports.	ENGLISH FRENCH SPANISH PORTUGUESE
TX START SPEED	Selects the speed at which the machine starts transmitting.	33600bps 14400bps 9600bps 7200bps 4800bps 2400bps
RX START SPEED	Selects the speed at which the machine starts receiving.	33600bps 14400bps 9600bps 7200bps 4800bps 2400bps
DAYLIGHT SAV TIME	Sets the daylight saving time (→ p. 3-9). If you select ON, you can select additional sub-settings.	OFF ON

Appendix Specifications

This appendix lists the machine's main specifications.

General Specifications	A-2
Printer	A-2
Facsimile	A-2
Copier	A-3
Telephone	A-3

General Specifications

Power Source

- 120–127 V
- 60 Hz

Power Consumption

- Max.: 660 W
- Standby: Approx. 3.5 W

Weight

Approx. 22 lb./10 kg (With components attached)

Dimensions

→ p. 2-2

Environmental Conditions

- Temperature: 50°F–90.5°F (10°C–32.5°C)
- Humidity: 20%–80% RH

Liquid Crystal Display (LCD)

16 × 1

Display Languages

English/French/Spanish/Portuguese

Applicable Standards

- Electrical Safety: UL1950, C-UL
- Radiation: FCC Part 15 Class B, IC
- Other: FCC Part 68, IC CS-03, Energy Star compliant

ADF Capacity

→ p. 4-2

Multi-Purpose Tray Capacity

→ p. 5-2

Printable Areas

→ p. 5-3

Scanned Area

→ p. 4-2

Printer

Printing Method

Laser beam printing

Paper Handling

Automatic feed

Print Media Size and Weight

→ p. 5-2

Recommended Print Media

→ p. 5-4

Print Speed

Approx. 6 pages/minute

Print Width

Max. 8.2 in. (208 mm)

Resolution

600 × 600 dpi

Printing Cartridge

FX-3 S Cartridge** (Yield: Approx. 1,500 pages)
FX-3 Cartridge (Yield: Approx. 2,700 pages)

Toner Saver

Approx. 30% to 40% reduction in toner consumption

Facsimile

Applicable Line

Public Switched Telephone Network (PSTN)

Compatibility

G3

Data Compressing System

MH, MR, MMR

Modem Type

Fax modem

Modem Speed

33.6/31.2/28.8/26.4/24/21.6/19.2/16.8/14.4/12/9.6/
7.2/4.8/2.4 Kbps

Transmission Speed

Approx. 3 seconds/page* at 33.6 Kbps,
ECM-MMR, transmitting from memory

Scanning Image Processing

- Ultra High Quality (UHQ™) image enhancement
- Halftones: 64 levels of gray
- Density adjustment 3 levels

Transmission/Reception Memory

Approx. 350 pages*

Fax Scanning Speed

Approx. 7.7 seconds/page*

* Based on ITU-T No. 1 Chart, standard mode.

** Supplied with the machine.

Fax Resolution

- FAX STANDARD: 203 pels/in. × 98 lines/in.
(8 pels/mm × 3.85 lines/mm)
- FAX FINE: 203 pels/in. × 196 lines/in.
(8 pels/mm × 7.7 lines/mm)
- FAX PHOTO: 203 pels/in. × 196 lines/in. with
halftones (8 pels/mm × 7.7 lines/mm with
halftones)
- SUPER FINE: 203 pels/in. × 392 lines/in.
(8 pels/mm × 15.4 lines/mm)

Dialing

- Automatic dialing
 - One-touch speed dialing (15 destinations)
 - Coded speed dialing (100 destinations)
 - Group dialing (Max. 114 destinations)
 - Directory dialing (with Directory button)
- Regular dialing (with numeric buttons)
- Automatic redialing
- Manual redialing
- Pause button
- Redial button

Networking

- Sequential broadcasting (Max. 116 destinations)
- Automatic reception
- Automatic fax/tel switchover
- Delayed transmission (Max. 116 destinations)
- Polling transmission
- Polling reception
- Remote reception by telephone (Default ID: 25)
- Non-ring reception
- ECM deactivation
- DRPD (Distinctive Ring Pattern Detection)
- ACTIVITY REPORT (after every 20 transactions)
- Non-delivery report
- TTI (Transmit Terminal Identification)

Copier**Scanning Resolution**

- Direct Copy: 400 × 300 dpi
- Memory Copy: 200 × 300 dpi

Printing Resolution

600 × 600 dpi

Reduction

70%, 80%, 90%

Copy Speed

Approx. 6 pages/minute

No. of Copies

Max. 99 copies

Telephone**Connection**

- Handset
- Extension telephone/answering machine (CNG
detecting signal)/data modem

- ▼ button 2-12, 14-3
- ◀ button 2-12, 3-4
- ▶ button 2-12, 3-3, 3-4
- ▲ button 2-12, 14-3
- (→ p. n-nn), definition 1-5
- (→ Software User's Guide), definition 1-5
- 1-TOUCH SPD DIAL LIST 1
 - description 11-2
 - printing 6-19
 - sample 6-20
- 1-TOUCH SPD DIAL LIST 2
 - description 11-2
 - printing 6-19
 - sample 6-20

A

- A4 setting 5-2, 5-9, 14-8
- ACTIVITY REPORT
 - description 11-2
 - printing 11-3
 - sample 11-3
 - setting 14-5
- ADF 2-11
 - adding pages in 4-4
 - capacity 4-2
 - jams in 13-2
- ALARM VOLUME setting 14-4
- ANS.MACHINE MODE
 - description 8-2
 - setting 8-9
- AnsMode setting. *See* ANS.MACHINE MODE
- Answering machine
 - connecting 2-8
 - using machine with 8-9
- Area
 - printable 5-3
 - scanned of document 4-2
- Assembling, machine 2-6
- AUTO REDIAL
 - message 13-8
 - setting 7-10, 14-6
- Automatic Document Feeder. *See* ADF
- Automatic redialing
 - canceled 7-9, 7-10
 - definition 7-9
 - setting options for 7-10, 7-11

B

- Broadcasting, sequential 7-12 to 7-14
- BUSY/NO SIGNAL message 13-8
- Button. *See individual button names*

C

- CALLING VOLUME setting 14-4
- Canceling
 - polling receiving 9-11
 - receiving 8-12
 - redialing 7-9, 7-10
 - sending 7-8
- Cartridge 2-3
 - compartment 2-11
 - installing 2-13 to 2-15
 - replacing 12-7 to 12-9
- CHANGE CARTRIDGE message 12-7, 13-8, 13-9
- CHANGE DATA setting 9-16, 14-9
- CHECK COVER message 13-9
- CHECK DOCUMENT message 13-2, 13-9
- CHECK PAPER SIZE message 13-9
- CHECK POLLING ID message 13-9
- CHECK PRINTER message 13-9
- CHK SUBADDR/PSWD message 13-10
- Cleaning
 - scanner components 12-5, 12-6
 - machine's exterior 12-2
 - machine's interior 12-2 to 12-4
- Clear button 2-12, 3-4
- CLEAR PAPER JAM message 13-3, 13-10
- Coded Dial button 2-12, 6-2, 6-16, 6-17
- CODED SPEED DIAL LIST 1
 - description 11-2
 - printing 6-19
 - sample 6-21
- CODED SPEED DIAL LIST 2
 - description 11-2
 - printing 6-19
 - sample 6-21
- Coded speed dialing 6-2, 7-4
 - making telephone call with 6-17
 - registering 6-8 to 6-12
 - sending with 6-16
- Components, machine 2-11, 2-12. *See also individual component names*

- Connecting
 - answering machine 2-8
 - data modem 2-8
 - external device 2-8
 - handset 2-8
 - power cord 2-9
 - printer cable 2-10
 - telephone 2-8
 - telephone line cord 2-8
 - to PC 2-10
 - USB cable 2-10
 - Contrast
 - copying, setting 7-3
 - sending, setting 7-3
 - Conventions, type 1-5
 - Copying 10-2, 10-3
 - document requirements 4-2
 - features 1-3
 - problems 13-18
 - Cord
 - answering machine 2-8
 - data modem 2-8
 - handset 2-8
 - power 2-3, 2-9
 - telephone 2-8
 - telephone line 2-3, 2-8
 - Correcting mistake 3-4
 - Cover
 - front 2-11
 - multi-purpose tray 2-3, 2-6, 2-11
 - CUSTOM setting 5-9, 14-8
 - CUSTOM1/LONG setting 5-2, 5-10
 - CUSTOM2/SHORT setting 5-2, 5-10
 - Customer support 1-6
- D**
- Data
 - modem, connecting 2-8
 - Registration button 2-12, 14-3
 - Date, entering 3-6
 - DATE & TIME setting 3-6, 14-4
 - DATE SETUP setting 14-10
 - Daylight Saving Time 3-9, 14-10
 - Default, definition 1-5
 - DEFAULT ACTION setting 8-4, 8-5
 - Delayed sending
 - deleting document set for 7-18
 - printing document set for 7-17
 - scanning a document into memory for 7-15, 7-16
 - Transmission button 2-12, 7-15, 7-17, 7-18
 - DELETE FILE setting 9-16, 14-9
 - Deleting
 - document in memory 9-8
 - document set for delayed sending 7-18
 - polling box settings 9-15, 9-16
 - Delivery, paper. *See* Paper delivery
 - Destination labels 6-7, 6-15
 - Dialing
 - coded speed dialing. *See* Coded speed dialing
 - directory. *See* Directory
 - group dialing. *See* Group dialing
 - methods 7-4
 - one-touch speed dialing. *See* One-touch speed dialing
 - regular 7-4
 - special 9-2, 9-3
 - speed. *See* Speed dialing
 - switching temporarily to tone 9-3
 - through switchboard 9-2
 - Dimensions 2-2
 - Directory 6-2, 6-18
 - button 2-12
 - DISPLAY LANGUAGE setting 14-10
 - DOC. MEMORY LIST
 - description 11-2
 - printing 9-4
 - sample 9-4
 - DOC. TOO LONG message 13-10
 - Document
 - adding pages in ADF 4-4
 - definition 1-5
 - guide 2-11
 - loading 4-3, 4-4
 - problem 4-2
 - problems with multipage 4-3
 - quantity 4-2
 - requirements 4-2
 - scanned area 4-2
 - size 4-2
 - support 2-3, 2-6, 2-11
 - thickness 4-2
 - weight 4-2
 - Documentation 2-3
 - Basic Guide 1-4
 - FAXPHONE L80 User's Guide 1-4
 - Printer Driver Software User's Guide 1-4
 - Set-Up Instructions 1-4
 - using 1-4, 1-5
 - DOUBLE RING setting 8-11
 - DRPD
 - description 8-2
 - receiving with 8-10, 8-11
 - ring patterns 8-11
 - setting 8-10, 8-11, 14-7
- E**
- ECM RX
 - message 13-10
 - setting 14-7

ECM TX
 message 13-10
 setting 14-6
 ECONOMY PRT setting 5-11, 14-8
 Envelopes
 loading 5-5, 5-6
 printable area 5-3
 requirements 5-2
 selecting 5-4
 ERASE AFTER TX setting 9-13, 14-9
 ERROR TX REPORT, sample 11-4
 External device, connecting 2-8

F

F/T RING TIME setting 8-4, 8-5, 14-7
 Face-down delivery 5-7, 5-8
 slot 2-11, 5-7
 Face-up delivery 5-7, 5-8
 slot 2-11, 5-7
 Fax
 definition 1-5
 features 1-3
 FAX ONLY MODE
 description 8-2
 setting 8-8, 14-7
 FAX setting 14-4
 FAX/TEL AUTO SW setting 8-3, 14-7
 Fax/Tel Mode
 description 8-2
 setting 8-3
 setting options for 8-4, 8-5
 FaxOnly setting. *See* FAX ONLY MODE
 FAXPHONE. *See* Machine
 FaxTel setting. *See* Fax/Tel Mode
 Features, FAXPHONE 1-3
 FILE NAME setting 9-12, 14-9
 Fixing assembly 2-11
 Front cover 2-11
 Function button 2-12
 FX-3. *See* Cartridge

G

GROUP DIAL LIST
 description 11-2
 printing 6-19
 sample 6-22
 Group dialing 6-2, 7-4
 registering 6-13 to 6-15
 sending with 6-16
 Guide
 document 2-11
 paper 2-11

H

Handling, safety instructions 1-7, 1-8
 Handset
 attaching to your machine 2-7
 connecting 2-8
 manual sending via 7-6, 7-7
 Hook button 2-12, 6-17, 7-6, 9-3
 HORIZ & VERTICAL setting 14-8

I

Image Quality button 2-12, 7-2, 10-2
 INCOMING RING setting 14-7
 INSIDE IMAGE setting 14-4
 Installing toner cartridge 2-13 to 2-15

J

Jack 2-8
 Jams
 clearing 13-2 to 13-7
 in ADF 13-2
 in paper delivery slots 13-3
 inside machine 13-3 to 13-7
 paper 13-3 to 13-7

K

KEEP PRINTING setting 14-8
 KEYPAD VOLUME setting 14-4

L

Label 2-3
 destination 6-7, 6-15
 paper loading warning 2-6
 Latch 2-11
 LCD 2-12
 definition 1-5
 messages 13-8 to 13-12. *See also individual message names*
 Letter
 entering 3-2, 3-3
 mode 3-2, 3-3
 Lever, paper release 2-11, 13-4
 LGL setting 5-2, 5-9, 14-8
 LINE MONITOR VOL setting 14-4
 Lists. *See also individual list names*
 summary 11-2
 LOAD PAPER message 13-10
 Loading
 document 4-3, 4-4
 envelopes 5-5, 5-6
 paper 2-16 to 2-18
 transparencies 5-6
 Location
 choosing 2-2
 safety instructions 1-8, 1-9
 LTR setting 5-2, 5-9, 14-8

M

Machine 2-3
 assembling 2-6
 choosing location for 2-2
 cleaning 12-2 to 12-6
 clearing jams 13-2 to 13-7
 components 2-11, 2-12. *See also individual component names*
 connecting 2-8 to 2-10
 dimensions 2-2
 features 1-3
 name, registering 3-6, 3-7
 number, registering 3-6
 testing 2-18
 unpacking 2-3 to 2-5

Maintenance, safety instructions 1-7 to 1-9

MAN/AUTO SWITCH setting 14-7

MANUAL MODE
 description 8-2
 setting 8-6, 8-7

Manual redialing 7-9
 canceling 7-9

Manual sending via the handset 7-6, 7-7
 canceling 7-8

Manual setting. *See* MANUAL MODE

Memory
 deleting document in 9-8
 documents in 9-4 to 9-8
 printing document in 9-5
 printing list of documents in 9-4
 receiving when problem occurs 8-12
 Reference button 2-12, 9-4, 9-5, 9-6, 9-8
 scanning a document for delayed sending into 7-15, 7-16
 sending. *See* Memory sending
 sending document in 9-6, 9-7

MEMORY CLEAR REPORT 13-21
 description 11-2
 sample 13-21

MEMORY FULL message 13-11

MEMORY RX setting 14-7

Memory sending 7-5, 7-6
 canceling 7-8

MEMORY USED nn% message 13-11

Menu. *See also individual menu names*
 accessing 14-3
 definition 1-5
 system, understanding 14-2, 14-3

Messages. *See* LCD messages

MID PAUSE SET setting 14-6

Mistake, correcting 3-4

Multi-purpose tray 2-11
 capacity 5-2
 cover 2-3, 2-6, 2-11
 loading paper in 2-16 to 2-18

MULTI TX/RX (Transaction) REPORT 11-5
 description 11-2
 sample 11-5

MULTI TX/RX REPORT. *See* MULTI TX/RX (Transaction) REPORT

N

NO RX PAPER message 13-11

NO TEL # message 13-11

NORMAL RING setting 8-11

NOT AVAILABLE message 13-11

Number
 entering 3-2, 3-3
 mode 3-2, 3-3

Numeric buttons 2-12, 3-2

O

OFFHOOK ALARM setting 14-4

One-touch speed dialing 6-2, 7-4
 buttons 2-12, 6-2, 6-16, 6-17
 making telephone call with 6-17
 registering 6-3 to 6-7
 sending with 6-16

Operation panel 2-11, 2-12

OTHER RING TYPE setting 8-11

OUTPUT NO setting 14-5

OUTPUT YES setting 14-5

OUTSIDE IMAGE setting 14-4

P

Panel
 operation 2-11, 2-12

Paper
 delivery. *See* Paper delivery
 feeding problems 13-13
 guide 2-11
 jams 13-3 to 13-7
 loading 2-16 to 2-18
 loading warning label 2-6
 path 5-7
 printable area 5-3
 quantity 5-2
 release lever 2-11, 13-4
 requirements 5-2
 selecting 5-4
 size setting 5-2, 5-9, 5-10
 weight 5-2

Paper delivery
 face-down 5-7, 5-8
 face-up 5-7, 5-8
 selecting 5-7, 5-8
 selector 2-11, 5-7, 5-8
 slot, jams in 13-3

PAPER SIZE setting 5-9, 14-8

- Password
 - for polling box, setting 9-12 to 9-14
 - for polling receiving 9-9
 - registering for coded speed dialing 6-8 to 6-12
 - registering for one-touch speed dialing 6-3 to 6-7
 - PASSWORD setting 9-13, 14-9
 - Pause
 - button 2-12, 9-2
 - entering 9-2
 - PBX, definition 9-2
 - PC, connecting to FAXPHONE 2-10
 - Polling
 - another fax machine 9-9, 9-10
 - box. *See* Polling box
 - button 2-12, 9-10, 9-15
 - definition 9-9
 - receiving. *See* Polling receiving
 - sending. *See* Polling sending
 - Polling box
 - changing settings 9-15, 9-16
 - deleting settings 9-15, 9-16
 - scanning document into 9-15
 - setting up 9-12 to 9-14
 - POLLING BOX
 - menu 14-3, 14-9
 - setting 9-12, 9-16
 - Polling receiving
 - canceling 9-11
 - polling another fax machine 9-9, 9-10
 - Polling sending
 - changing polling box settings 9-15, 9-16
 - deleting polling box settings 9-15, 9-16
 - scanning document into polling box 9-15
 - setting up polling box 9-12 to 9-14
 - Power
 - cord 2-3, 2-9
 - failure 13-21
 - supply, safety instructions 1-9
 - switch 2-9
 - PRINT ERROR ONLY setting 14-5
 - Print media
 - loading 5-4 to 5-6
 - requirements 5-2, 5-3
 - selecting 5-4 to 5-6
 - PRINT WITH IMAGE setting 14-5
 - Printer
 - cable, connecting 2-10
 - features 1-3
 - PRINTER SETTINGS menu 14-3, 14-8
 - Printing
 - area 5-3
 - document in memory 9-5
 - document set for delayed sending 7-17
 - lists. *See individual list names*
 - problems 13-14
 - reports. *See individual report names*
 - Problems
 - cannot solve 13-20
 - copying 13-18
 - document 4-2
 - general 13-19
 - multipage document 4-3
 - paper feeding 13-13
 - printing 13-14
 - receiving 13-16 to 13-18
 - receiving in memory when 8-12
 - sending 13-15, 13-16
 - telephone 13-19
 - PSWD POLL REJECT message 13-11
 - PSWD TX REJECTED message 13-12
 - Pulse dialing
 - setting for 3-8
 - switching temporarily to tone dialing 9-3
- Q**
- Quantity
 - document 4-2
 - envelopes 5-2
 - paper 5-2
 - transparencies 5-2
- R**
- REC'D IN MEMORY message 8-12, 13-12
 - Receive Mode button 2-12
 - Receiving. *See also individual receive modes*
 - canceling 8-12
 - in memory when problem occurs 8-12
 - methods 8-2
 - polling. *See* Polling receiving
 - problems 13-16 to 13-18
 - remote, definition 8-6
 - restricting 9-17
 - while performing other tasks 8-12
 - Reception report. *See* RX (Reception) REPORT
 - Redial button 2-12, 7-9
 - REDIAL INTERVAL setting 7-11, 14-6
 - REDIAL TIMES setting 7-11, 14-6
 - Redialing 7-9 to 7-11
 - Remote reception, definition 8-6
 - REMOTE RX ID setting 14-7
 - REMOTE RX setting 14-7
 - Replacing FX-3 cartridge 12-7 to 12-9
 - Report button 2-12, 6-19, 11-3, 14-2
 - REPORT SETTINGS menu 14-3, 14-5
 - Reports. *See also individual report names*
 - summary 11-2
 - Resolution
 - copying, setting 10-2
 - sending, setting 7-2
 - Restricting reception 9-17
 - RING COUNT setting 14-7
 - RING START TIME setting 8-4, 8-5

Roller, transfer charging 2-11
ROTARY PULSE setting 3-8, 14-4
RX (Reception) REPORT 11-5
 description 11-2
 sample 11-5
RX (Reception) SETTINGS menu 14-3, 14-7
RX CALL LEVEL setting 14-4
RX MODE setting 8-3, 8-8, 8-11, 14-7
RX PAGE FOOTER setting 14-7
RX REDUCTION setting 14-8
RX REPORT. *See also* RX (Reception) REPORT
 setting 14-5
RX RESTRICTION setting 9-17, 14-10
RX SETTINGS menu. *See* RX (Reception) SETTINGS
 menu
RX START SPEED setting 14-10
RX TO MEMORY setting 14-8

S

S Cartridge 2-3, 2-13
Safety instructions 1-7 to 1-9
Saving, toner consumption 5-11
SCAN CONTRAST setting 7-3, 14-4
Scanner components, cleaning 12-5, 12-6
Scanning
 contrast, copying 7-3
 contrast, sending 7-3
 document area 4-2
 document into memory for delayed sending 7-15,
 7-16
 resolution, copying 10-2
 resolution, sending 7-2
SELECT POL REJECT message 13-12
Selector, paper delivery 2-11, 5-7, 5-8
Sender information
 definition 3-5
 registering 3-5 to 3-7
 sample 3-5
Sending
 at preset time. *See* Delayed sending
 canceling 7-8
 delayed. *See* Delayed sending
 document in memory 9-6, 9-7
 document requirements 4-2
 manual via the handset 7-6, 7-7
 memory 7-5, 7-6
 methods 7-5 to 7-7
 polling. *See* Polling sending
 problems 13-15, 13-16
 same document to several fax numbers
 7-12 to 7-14
 timer. *See* Delayed sending
 with coded speed dialing 6-16
 with group dialing 6-16
 with one-touch speed dialing 6-16
 with speed dialing 6-16

Sequential broadcasting 7-12 to 7-14
Serial number, machine 13-20
Set button 2-12, 14-3
Settings. *See also individual setting names*
 printing list of 14-2
SETUP FILE setting 9-12, 14-9
Shipping materials, removing 2-5
SHORT-LONG-SHORT setting 8-11
SHORT-SHORT-LONG setting 8-11
Size
 document 4-2
 envelopes 5-2
 paper 5-2, 5-9, 5-10
 transparencies 5-2
Space button 2-12, 3-3
Special function buttons 2-12. *See also individual
 button names*
Speed dialing. *See also individual speed dialing
 methods*
 definition 6-2
 lists. *See* Speed dialing lists
 making telephone call with 6-17
 methods 6-2
 sending document with 6-16
 using 6-16, 6-17
Speed dialing lists. *See also individual list names*
 printing 6-19 to 6-22
 samples 6-20 to 6-22
Standby mode 2-12
Start/Copy button 2-12, 7-6, 7-7, 10-2, 10-3
Starter cartridge 2-13, 12-7
Stop/Reset button 2-12, 14-3
SUBADD TX REJECT message 13-12
Subaddress
 for polling receiving 9-9
 registering for coded speed dialing 6-8 to 6-12
 registering for one-touch speed dialing 6-3 to 6-7
Support
 customer 1-6
 document 2-3, 2-6, 2-11
 tray 2-3, 2-6, 2-11
Switchboard, dialing through 9-2
Symbols, entering 3-2, 3-3
SYSTEM SETTINGS menu 14-3, 14-10

T

TEL LINE TYPE setting 3-8, 14-4
TEL setting 8-12, 14-4
Telephone
 connecting 2-8
 features 1-3
 making call with speed dialing 6-17
 problems 13-19
TELEPHONE # MARK setting 14-4
Telephone line
 cord 2-3, 2-8

- type, setting 3-8
- Testing FAXPHONE 2-18
- Thickness, document 4-2
- Time
 - entering 3-6
 - sending at preset. *See* Delayed sending
- TIME OUT setting 14-6
- Timer sending. *See* Delayed sending
- Tone dialing
 - setting for 3-8
 - switching temporarily to 9-3
- Toner saver setting 5-11
- TONER SUPPLY LOW setting 14-8
- TOUCH TONE setting 3-8, 14-4
- Transfer charging roller 2-11
- Transmission report. *See* TX (Transmission) REPORT
- Transparencies
 - loading 5-6
 - requirements 5-2
 - selecting 5-6
- Tray
 - multi-purpose 2-11
 - multi-purpose, cover 2-3, 2-6, 2-11
 - support 2-3, 2-6, 2-11
- TTI POSITION setting 14-4
- TX (Transmission) REPORT 11-4
 - description 11-2
 - sample 11-4
- TX (Transmission) SETTINGS menu 14-3, 14-6
- TX PASSWORD setting 9-13, 14-9
- TX REPORT. *See also* TX (Transmission) REPORT
 - setting 14-5
- TX SETTINGS menu. *See* TX (Transmission)
 - SETTINGS menu
- TX START SPEED setting 14-10
- TX TERMINAL ID setting 14-4
- TX/RX CANCELLED message 13-12
- TX/RX NO. nnnn message 13-12
- TX/RX NO. nnnn, SCANNING P.nnn, MEMORY FULL
 - message 13-12
- Type conventions 1-5

U

- UNIT NAME setting 3-6, 14-4
- UNIT TELEPHONE # setting 3-6, 14-4
- Unpacking machine 2-3 to 2-5
- USB cable, connecting 2-10
- USER SETTINGS menu 14-3, 14-4
- USER'S DATA LIST
 - description 11-2
 - printing 14-2
 - sample 14-2
- User's Guide 1-4
 - type conventions 1-5

V

- VERTICAL ONLY setting 14-8
- Volume
 - ALARM VOLUME setting 14-4
 - CALLING VOLUME setting 14-4
 - KEYPAD VOLUME setting 14-4
 - LINE MONITOR VOL setting 14-4
 - VOLUME CONTROL setting 14-4
- VOLUME CONTROL setting 14-4

W

- Weight
 - document 4-2
 - machine A-2
 - paper 5-2